

# Invivo5

Invivo5.4 Reference Manual

English

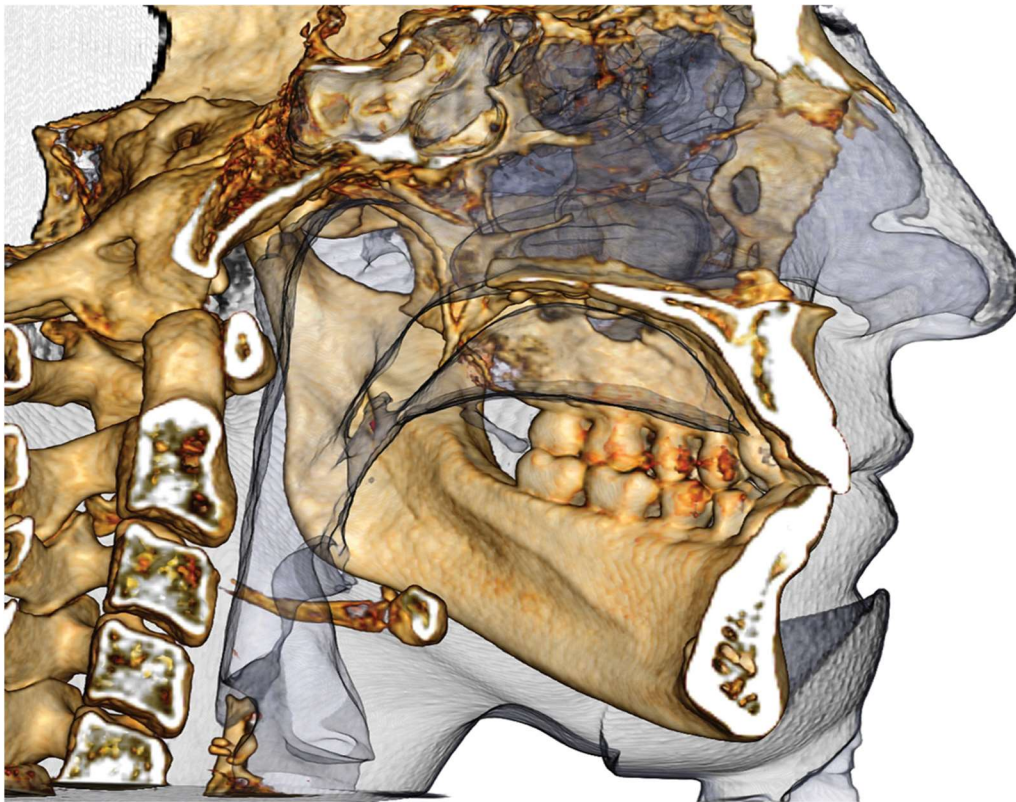

*Anatomage*

Anatomage, Inc. 3350 Scott Blvd Bldg 29, Santa Clara, CA 95054, U.S.A.  
Tel) 408.333.3484 Fax) 408.295.9786 [www.anatomage.com](http://www.anatomage.com)

## Warranty Statement

There are no warranties, express or implied, with respect to the contents of this document, and all information provided herein is provided “as is.” Anatomage reserves the right to periodically change the information that is contained in this document; however, Anatomage makes no commitment to provide any such changes in a timely manner or at all.

## Limitation of Liability

In no event shall Anatomage or its affiliates be liable to any party for any direct, indirect, special, or consequential damages in connection with your use of this document, including, without limitation, loss of business revenue or earnings, lost data, damages caused by delays, lost profits, or a failure to realize expected savings, even if Anatomage was expressly advised of the possibility of such damages.

## End of Life Statement

Osteoid is committed to the continuous improvement of InVivoDental by utilizing state-of-the-art technology and trends to provide the most comprehensive software for the diagnoses of patients. The “shelf life” of InVivoDental software has been defined as 3 years from the release to ensure the highest level of patient care and safety. Notification of software improvements and new releases will be provided to customers to update to the latest version. Previous (older) versions may continue to be utilized, but support may be limited and the software may no longer receive security patches or software updates. If the device remains in service following the end of support, the cybersecurity risks for end-users can be expected to increase over time.

## Trademarks

Anatomage and related marks, images, and symbols are the exclusive properties of, and trademarks of, Anatomage Inc. All other brands and marks are the properties of their respective owners.

## Copyright

Documentation for InVivoDental and the operating software are copyrighted with all rights reserved. Under the copyright laws, this documentation may not be reproduced, transmitted, transcribed, or translated into any human or computer language in whole or part without the prior written permission of the copyright holder.

## About Anatomage and InVivoDental Software

This version of InVivoDental was released as an update to the original InVivoDental software from Anatomage, Inc. In this document, InVivoDental refers to the latest version of the Anatomage InVivoDental software and is synonymous with the terms “Invivo” and “Invivo5.” To learn more about Anatomage, access the Anatomage website ([www.Anatomage.com](http://www.Anatomage.com)).

## Intended User

InVivoDental is designed to be used by medical and dental professionals who have been appropriately trained to use 3D CT imaging devices and read the image data generated by the devices.

## Language

The original language of this manual is English. Other versions are available. Please contact Anatomage for other language versions.

**Caution:** Federal law restricts this device to sale by or on the order of medical and dental clinicians.

## Indications for Use

InVivoDental is a software application used for the display and 3D visualization of medical image files from scanning devices, such as CT, MRI, or 3D Ultrasound. It is intended for use by radiologists, clinicians, referring physicians, and other qualified individuals to retrieve, process, render, review, store, print, assist in diagnosis and distribute images, utilizing standard PC hardware. Additionally, InVivoDental is a preoperative software application used for the simulation and evaluation of dental implants, orthodontic planning, and surgical treatments.

This device is not indicated for mammography use.

## Security Precautions

- Restrict access by requiring a username and password in operating system security settings. Only assign login credentials to trusted individuals within your organization. Refer to operating system website or customer support for instructions.
- Ensure that system restore and backup functionality is enabled. The ability to toggle system restore and backup should be restricted to system administrators.
- Enable multi-factor authentication where possible.
- Use cybersecurity controls such as a firewall, anti-virus, anti-malware, etc.
- InvivoDental requires internet access for license verification. Ensure that the network you will be using with the software is secure.
- To set up the controls recommended above, contact your internal IT team, operating system manufacturer, internet service provider (ISP), modem/router manufacturer, or refer to manufacturer website/documentation.
- Customers who purchase and use InvivoDental are ultimately responsible for the implementation of safe and secure practices for the protection of patient data.
- Note: To request a copy of the InvivoDental Software Bill of Materials (SBOM), or the list of data ports used by the software, or the instructions to ensure sensitive data is completely removed after uninstalling the software, e-mail [support@osteoidinc.com](mailto:support@osteoidinc.com)

## General Precautions



Warning: The software provides tools for dental prosthetics creation and design but is dependent on the user to determine and use the appropriate parameters. Incorrect parameters may affect the quality of the final milled products or otherwise to surgical delays or complications.



Warning: Please ensure all hardware devices with the software are password-protected from unauthorized use and all patient information is secure.

# Table of Contents

Table of Contents .....	4
Introduction .....	10
System Requirements .....	11
Installing Invivo .....	13
About the License Type.....	13
Perpetual Licenses .....	13
Network Licenses .....	13
Internet Requirement .....	13
Website Installation Instructions .....	13
InVivoDental Setup Wizard.....	14
Validating the Installer File.....	16
Feature List .....	17
Software Layout.....	18
Invivo Preferences .....	19
Display Preferences .....	19
Volume Rendering Preferences .....	21
File Manager Settings.....	22
Basic Features .....	24
DICOM & Invivo File Loading with the File Manager.....	24
Invivo/DICOM File Saving.....	26
Invivo.....	26
DICOM .....	26
Custom Saving Dialog .....	27
Saving As an Invivo Project File.....	27
DICOM File Loading with PACS .....	28
PACS Configuration .....	28
PACS File Loading.....	28
PACS File Saving.....	29
Lay Egg.....	29
Export to CD.....	29
Case Information Display .....	30
Image Capture to File .....	30
Image Capture to Gallery.....	31
Image Capture to an Email .....	31
Image Navigation .....	32

Slider Scroll ..... 32

Zoom In/Out ..... 32

Pan (Shift) ..... 32

Free Rotate..... 33

Free Rolling..... 33

Increment Rotate..... 33

Increment Roll ..... 33

Anatomical Plane Clipping..... 34

Scroll Slice..... 34

Move/Rotation Widget..... 34

3D Restoration Widget..... 34

Full Screen Mode and Keyboard Shortcuts ..... 35

Switching to Full Screen Mode..... 35

Keyboard Shortcuts at Volume Rendering View..... 35

The View Tabs ..... 36

Section View Features ..... 36

Section: Toolbar ..... 37

Section: Control Panel ..... 39

Section: Rendering Window..... 41

Section: Airway Measurement ..... 42

Section: Light Box ..... 43

Volume Render View Features..... 44

Volume Render: Toolbar ..... 45

Volume Render: Control Panel ..... 47

Volume Render: Patient Orientation ..... 48

Volume Render: Render Window..... 49

Volume Render: Volume Measurements..... 50

Volume Render: Airway Measurement ..... 51

Volume Render: Movie Capturing and Customized View Sequences ..... 52

ArchSection View Features..... 53

ArchSection: Toolbar..... 54

ArchSection: Control Panel..... 56

ArchSection: Creating A Nerve Pathway ..... 58

ArchSection: Rendering Window ..... 59

Implant View Features ..... 60

Implant: Toolbar ..... 61

Implant: Control Panel ..... 63

Implant: Rendering Window ..... 65

Implant: View Preset Setup..... 66

Implant: Model Visibility ..... 67

Implant: 3D Implant Widget..... 67

Implant: 2D Implant Widget..... 67

Implant: 3D Implant Planning ..... 68

Implant: Pano Implant Planning ..... 69

Implant: Bone Graft Simulation..... 70

Implant: Advanced Restoration Design..... 71

Implant: Adding Restorations ..... 71

Implant: Check Sleeves ..... 72

Implant: View Sequencer ..... 73

Implant: Settings and Preferences ..... 75

    Detailed Implant Settings..... 76

    Preferred Implants Settings..... 76

    Density Profile Control..... 77

Restoration View Features ..... 78

Restoration: Toolbar..... 79

Restoration: Control Panel..... 81

Restoration: Stone Model Registration ..... 82

Restoration: Rendering Window & Mesh Manipulation..... 84

Restoration: View Preset Setup ..... 85

Restoration: Abutment Planning..... 86

Restoration: Abutment Planning Dialog..... 86

    Abutment Parameters ..... 86

Restoration: Crown Types..... 88

    Crowns for prepped teeth or custom abutments ..... 88

    Pontics ..... 88

    Bridges ..... 89

Restoration: Articulation and Adjust Occlusion..... 90

Restoration: Preferences ..... 91

TMJ View Features..... 92

TMJ: Toolbar..... 93

TMJ: Control Panel..... 95

TMJ: Rendering Window ..... 96

    Arch Spline (Focal Trough) Navigation..... 96

TMJ: Layout ..... 97

Super Pano View Features ..... 98

Super Pano: Toolbar ..... 99

Super Pano: Control Panel ..... 100

Super Pano: Rendering Window ..... 101

    How to make a good Pano? ..... 101

Super Ceph View Features ..... 102

Super Ceph: Toolbar ..... 103

Super Ceph: Control Panel ..... 104

Super Ceph: Rendering Window ..... 105

Superimposition View Features ..... 106

Superimposition: Toolbar ..... 107

Superimposition: Control Panel ..... 109

Superimposition: How to Superimpose Two Volumes ..... 111

Superimposition: Using Superimposition Aligner for Fine Adjustments ..... 113

Superimposition: Using Volume Registration for Fine Adjustments ..... 114

Superimposition: Difference Between .vdata Files and .odata Files ..... 116

Gallery View Features ..... 117

Gallery: Toolbar ..... 118

Gallery: Control Panel ..... 118

Gallery: Rendering Window ..... 119

Gallery: Adding Images to the Gallery ..... 120

Gallery: 2D Image Options ..... 122

Model View Features ..... 123

Model: Toolbar ..... 124

Model: Control Panel ..... 126

Model: Rendering Window ..... 128

Model: Custom Preset Setup ..... 129

Model: Simulations ..... 130

Common How to Tasks ..... 131

How to Trace a Nerve ..... 131

How to Create Reports In Life Size ..... 132

    Other View Tabs with Life-Size Printing ..... 132

How to Create a Positive Airway View ..... 133

How to Create an AnatoModel Simulation and Video ..... 134

Invivo5 Additional Modules ..... 136

3DAnalysis Module Features ..... 137

3DAnalysis: Toolbar ..... 138

3DAnalysis: Control Panel ..... 140

3DAnalysis: Coordinate System ..... 141

3DAnalysis: Tracing Tasks ..... 146

    Tracing Task Examples and Tips..... 147

3DAnalysis: Text View..... 152

    Colored Wigglegram..... 154

3DAnalysis: VCA Mode..... 155

3DAnalysis: Advanced Analysis Configurations ..... 159

    Configuring a Frontal Analysis..... 159

    Configuring a Sassouni Analysis..... 159

3DAnalysis: Create Face Photo ..... 160

3DAnalysis: Landmark-Based Superimposition ..... 162

    Performing Landmark-Based Superimposition ..... 163

    Superimposition Text View..... 164

    How Does 3DAnalysis Work with the Superimposition Tab? ..... 165

3DAnalysis: Layout Options ..... 166

3DAnalysis: 3DAnalysis Settings ..... 167

    Special Landmark Properties..... 170

3DAnalysis: Tracing Guide ..... 178

3DAnalysis: Default Tracing Tasks and Landmarks ..... 180

3DAnalysis: Save Information..... 183

3DAnalysis: 3D Surgery Tool ..... 185

3DAnalysis: Profilogram ..... 188

Report Module Features ..... 189

Report: Control Panel..... 191

Report: Rendering Window ..... 192

Report: Controls..... 193

Report: Adding Text Controls..... 194

Report: Slice Group Management..... 196

    Adding Slices to a Group..... 197

    Capturing Slices..... 198

Report: Adding Slice Group Controls ..... 199

    Slice Image Source Details ..... 200

    Slice Control Selection Details ..... 201

Report: Adding Single Image Controls..... 202

Report: Image Alignment ..... 203

Report: Image Type Definitions..... 204



Report: Managing Templates ..... 205

Report: Preferences ..... 206

Report: Page Setup ..... 207

Stitching Module Features ..... 208

Stitching: Toolbar ..... 209

Stitching: Control Panel ..... 210

Stitching: How to Stitch Two Volumes ..... 211

Invivo5 Software Troubleshooting ..... 216

Index..... 218

# Introduction

## *InVivoDental Imaging Software*

Anatomage, Inc. is a medical imaging company composed of a cross-functional team consisting of the most elite researchers, mathematicians, engineers, software developers, business analysts, industry leaders, academic faculty, and dental specialists. We believe that InVivoDental software will enable the profession to initiate a revolution of unimaginable scope and magnitude. Ultimately, our mission is dedicated to developing simple and refined software specially designed for dentists to utilize the most advanced cutting edge software and technology to better serve their patients. With InVivoDental software, doctors can create 3D volume renderings on their own computers, get cross sections, trace nerves, place implants, print images, save images, and many more functions. The software is designed to reconstruct these 3D volume renderings from DICOM files generated by CBCT, Medical CT, and MRI radiography machines. InVivoDental is intended for use as a planning and simulation software in the placement of dental implants, orthodontics, and surgical treatment.

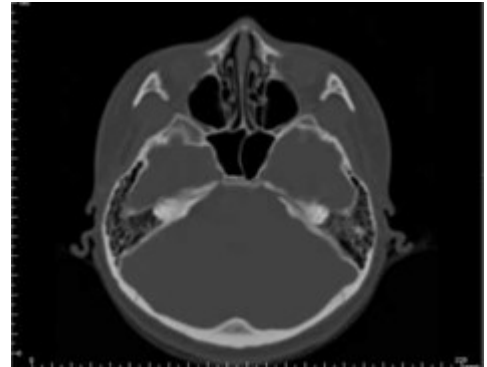

This manual is intended to provide supplementary information to your direct training with the Anatomage support team. For correct and safe use, training is available to all InVivoDental users and is highly recommended. In this document, InVivoDental refers to the latest version of the Anatomage InVivoDental software and is synonymous with the terms “Invivo” and “Invivo5.” Previously released versions of this manual are available. For more information on how to access previous versions of the InVivoDental Reference Manual, please contact the Anatomage customer support team at (408) 885-1474 or email [support@anatomage.com](mailto:support@anatomage.com)

# System Requirements

*Below are the minimal and recommended system configurations.*

**H**aving an adequate computer system is essential to using InVivoDental efficiently and generating the highest quality images possible for enhanced analysis and presentation for your patients and colleagues. The most important element is the video card (3D graphics chip or GPU). If your system does not have an appropriate video card, you can purchase and install video cards for desktop computers.

InVivoDental has minimal system requirements; however, Anatomage recommends the following configurations to fully utilize all the features within the InVivoDental Software. The following recommendations have been updated in November 2015:

## Summary

	Minimum	Recommended
<b>CPU</b>	Pentium 3	Intel Core i7 4000 series or comparable multi-core processor
<b>RAM</b>	3GB	4GB
<b>GPU / Graphics Card</b>	ATI Radeon HD 4650 <i>or</i> Nvidia GeForce 9800 GT	ATI Radeon HD 6800 or comparable
<b>Hard Disk</b>	100 GB	500 GB
<b>OS</b>	Windows 7 32-bit	Windows 7 64-bit, Windows 8* 64-bit, or Windows 10* 64-bit <small>*For versions 5.1 and up</small>

## Mac Users

	OS	Hardware
<b>Not Compatible</b>	Apple OS, Parallels	MacBook Air, Mac Mini
<b>Fully Compatible</b>	Apple Bootcamp (requires a full license of Windows)	iMac, MacBook Pro (15in), Mac Pro Note: Please check if a dedicated graphics card (Nvidia/Radeon) is included.

## Graphics Cards / GPU Details

Brand	Model Series	Low-End Options	Recommendation	High-End Options
ATI	Radeon HD 4600 – R9 290X	Radeon HD 6450	Radeon HD 6800 series	Radeon HD 7970 Radeon R9 290X
Nvidia	GeForce GT 430 – GeForce GTX Titan	GeForce GT 635 GeForce GTX 645	GeForce GTX 650	GeForce GTX 760 GeForce GTX 660 Ti

## Laptop Recommendations

**IMPORTANT: Ensure the laptop has a dedicated video card. Integrated graphics cards alone, such as Intel HD Graphics, are insufficient for 3D rendering.**

**Note: Graphics processor options may vary. Please check with the laptop manufacturer for details on graphics processor options.**

### Dell

Sizes	Model Series	Graphics Processor Options	Weight
11", 14", 17", 18"	Alienware M	Nvidia GeForce 765M Note: Known issue with new GT 700M series drivers; will only work with "Nvidia driver 311.48.1.3.24.2" as of 1/29/2014	4.4 – 11.7 lbs
15", 17"	Inspiron R	ATI Radeon HD 8850M or Nvidia GeForce GT 750M	6.1 - 7.3 lbs
15", 17"	Studio XPS	Nvidia GeForce GT 730M or GT 740M or better	5.8 - 7.4 lbs

**HP** (Warning: HP brand laptops have a known issue with switchable graphics. A BIOS update from the HP website may be necessary to run Invivo5 with the intended graphics hardware.)

Sizes	Model Series	Graphics Processor Options	Weight
15", 17"	Envy	ATI Radeon HD 8750M or Nvidia GeForce GT 750M	5.6 – 7.5 lbs
15", 17"	Pavilion	ATI Radeon HD 8670M	5.5 - 6.6 lbs

For additional information, recommendations or assistance, please contact the Anatomage Tech Support Department at (408) 885-1474 or email [support@anatomage.com](mailto:support@anatomage.com)

# Installing Invivo

## About the License Type

The authorization code provided for activation should be one of the two license types below. If the license type is not known, please contact the distributor of the license, which can be either Anatomage or a partner CBCT scanner manufacturer that bundles Invivo licenses.

### Perpetual Licenses

- This is a single-use license for one computer. Internet connection will be required for the initial installation but not during subsequent use of the software. If Internet access is not available, the license can be manually activated by the distributor's tech support.

### Network Licenses

- This license can install up to four computers that are on the same Internet network as at least one perpetual-licensed computer. Hence, a network license can only be used after a perpetual computer is installed. Internet connection will be necessary to launch the software.

Note: Please ensure each code is entered on the desired computer. Once a code has been activated, you must contact the distributor of the license to transfer the license. Invivo licenses are not interchangeable between the PC and Mac versions.

## Internet Requirement

While perpetual computers only need Internet connection during the initial installation, network computers will require Internet to access the software. If the Internet connection becomes unavailable, the network computers will fall onto a grace period of eight hours. After the grace period ends, the license will be inactive until Internet connection linked to a perpetual computer is reestablished.

## Website Installation Instructions

1. Go to [www.Anatomage.com](http://www.Anatomage.com)
2. Select "Dr. Login."
  - Username: download
  - Password: softwarefiles
3. Click on the Invivo Installer.
4. Click "Save File."
5. Run File.

### InVivoDental Setup Wizard

Before proceeding, please ensure the computer is connected to the Internet. InVivoDental Setup will check for certain components that are important to the performance of the software. A result of “Pass” or “Fail” will be provided as the components for that computer are compared to a list of the most compatible components. A Fail result will not prevent the installation from completing and is only intended as a warning of the possibility of suboptimal software performance as a result.

OpenGL Vendor: Associated with the manufacturer of the graphics processor

OpenGL Version: Associated with the driver version of the graphics hardware component

Memory: The quantity of RAM installed on the motherboard

Click Next to continue.

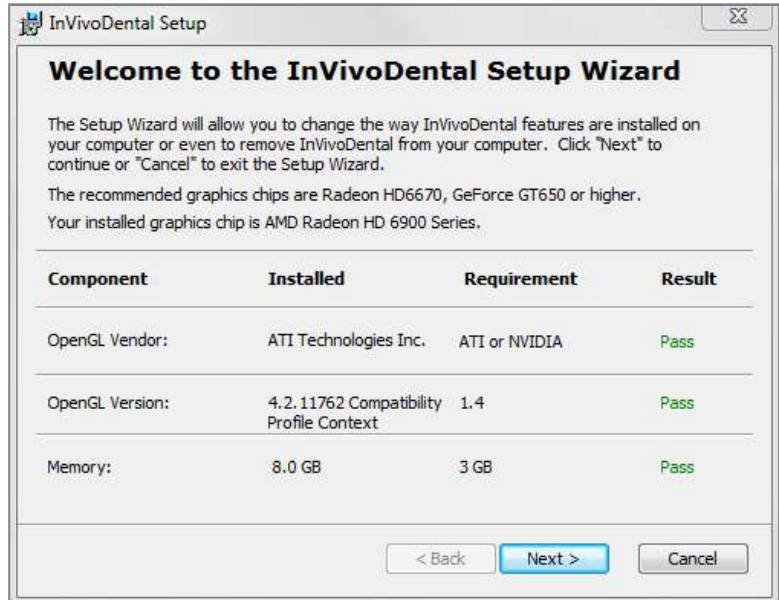

Enter the numerical authorization code. If you have an alphanumeric license key, click Advanced and put in the key in the blank provided.

Click Next to continue.

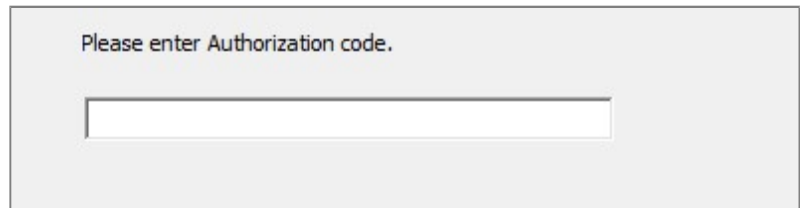

Installation Preferences: The user can specify the folder for software installation as well as the level of functionality with which the software initially opens. A PACS-compatible user interface can also be installed instead of the typical File Manager.

Full Functionality Mode: Selecting this option will have all view tabs enabled after the installation is complete.

Unchecking this function will install the software with only Section, ArchSection, Volume Render, Implant, Gallery, and Model Tabs visible. The missing tabs can be enabled in the Preferences dialog of the File menu.

PACS Options: Files can be opened from or saved onto PACS through the PACS user interface. Selecting “Full PACS” will disable opening or saving files locally. Selecting “Export PACS Only” options will disable saving files locally.

*Only select these options if you have a PACS in place.*

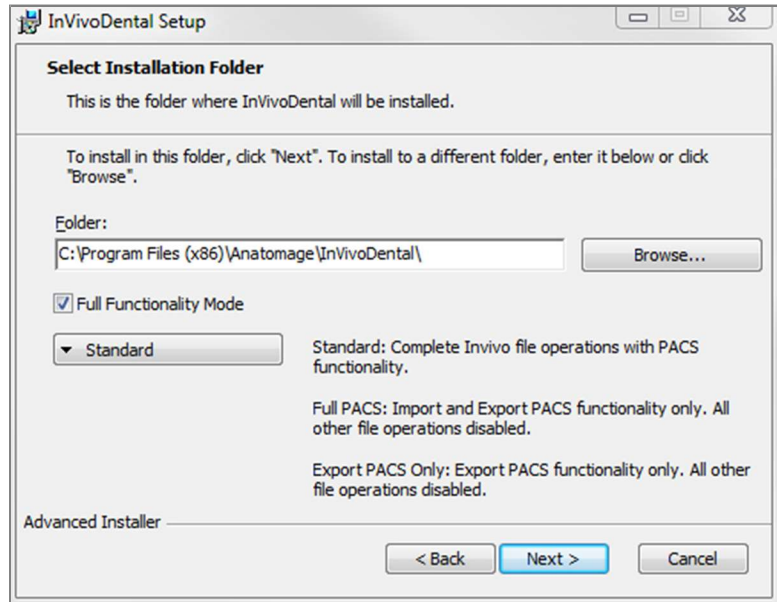

Review the End-User License Agreement and accept the terms if desired to proceed with the installation.

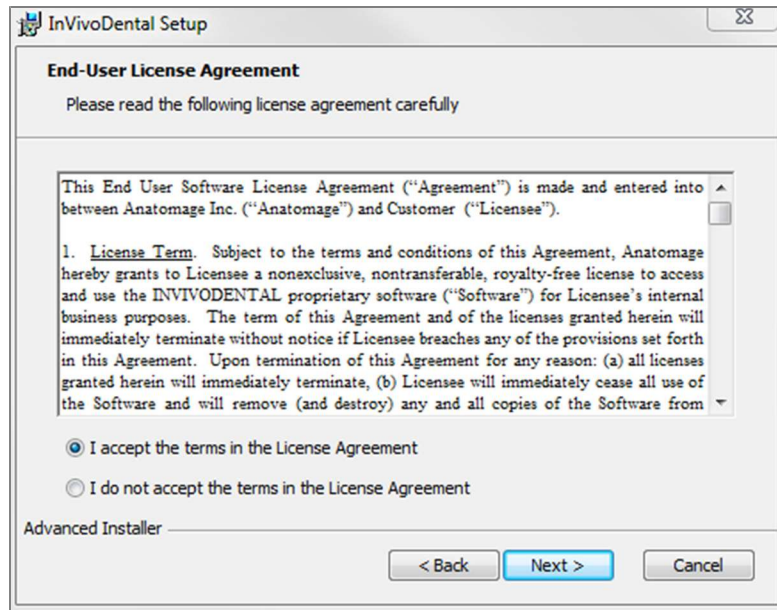

Click Next to continue. The program will proceed with installation until completed. Clicking Finish will close the wizard.

## Validating the Installer File

1. Right-click the Installer file and select “Properties” to open the Properties window.
2. Open the “Digital Signatures” Tab.
3. Select “Anatomage, Inc.” and press Details.
4. Verify that the Digital Signature Information is “OK.”

*The following pictures are for demonstration purposes only. The name of the installer and Digital Signature Information is dependent on the release version and may change accordingly.*

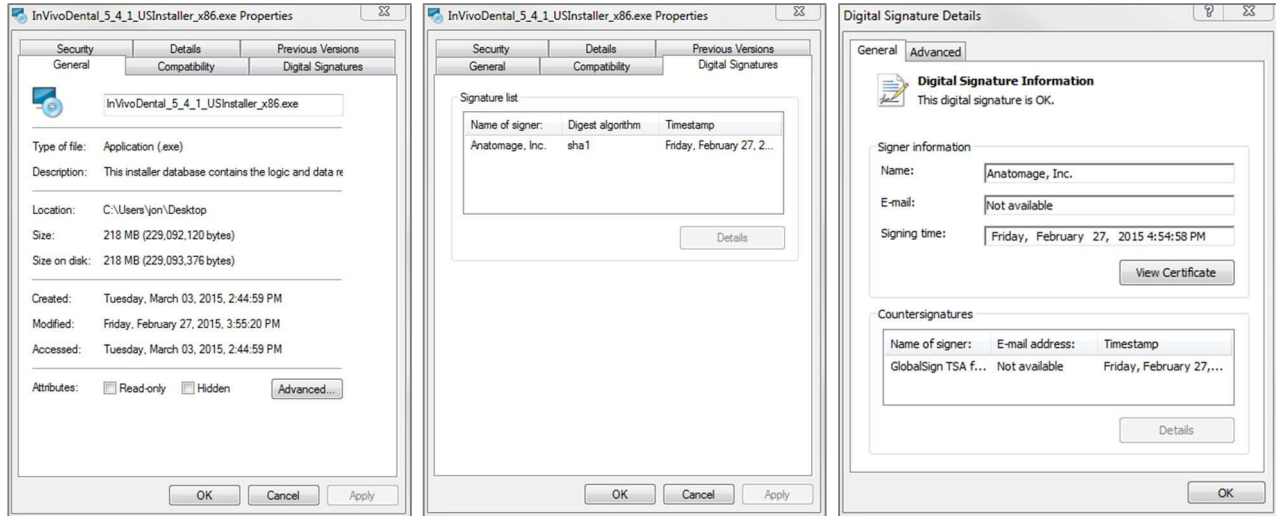



# Feature List

*An overview of the various features provided by Invivo.*

- Directly Opens DICOM Data from Any CT Machine
- Invivo File Compression
- Section and Multislice View Operations
- Volume Rendering of Scan Data
- Linear, Angular, Circumferential, Area, and Volumetric Measurements\*
- Image Capture and Export
- AVI (Movie) Capture and Export
- Implant, Abutment, and Restoration Treatment Planning
- Bone Density Evaluation
- Quick Airway Volume Measurement and Evaluation
- Automatic Superimposition and Mirroring
- Platform for the AnatoModel Service

\*All measurements are performed with the metric system.

# Software Layout

The following is a description of how Invivo is organized by Menu Bar, Toolbar, View Tabs, View Control Panel, and Rendering Window.

**Menu Bar**  
The Menu Bar allows you to perform application operations such as open, save, close, print, capture, etc.

**Toolbar**  
Tools can be accessed to perform certain functions on patient images. Sets of tools are associated with a specific View Tab.

**View Tabs**  
The View Tabs allow you to perform specific tasks or look at specific subjects of interest by adjusting the Toolbar and View Controls

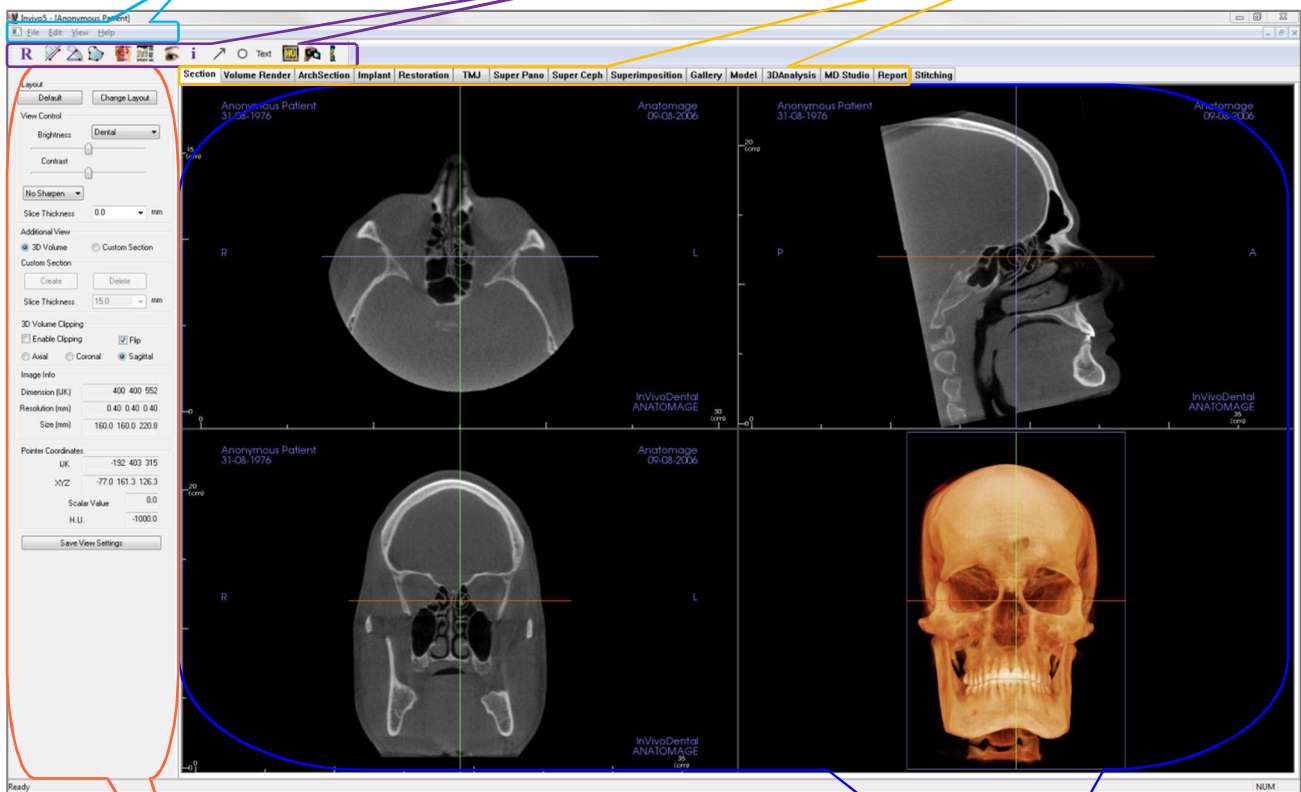

**View Control Panel**  
The View Control Panel is the region where patient images can be manipulated and controlled. The View Control Panel is associated with a specific View Tab.

**Rendering Window**  
Rendering Window is the region where patient images are displayed. This window can be customized within many of the View Tabs by using the Toolbar.

# Invivo Preferences

This section will explain the different options within the Preference window of Invivo. The Invivo preferences include options for Display settings, Volume Rendering settings, as well as File Manager settings.

Accessing the Invivo Preferences:

- In the Menu bar of the Invivo, select “File.”
- Select “Preference...” from the “File” drop-down.

## Display Preferences

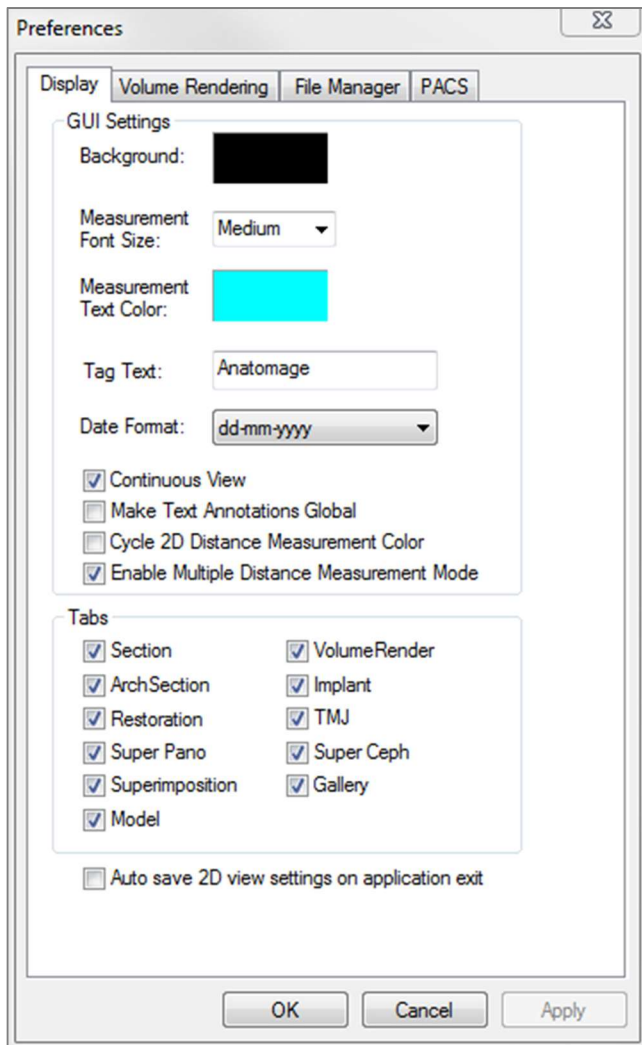

### GUI Settings

- **Background:** Sets the background color for the rendering window.
- **Measurement Font Size:** Sets the measurement font size to a size preset: small, medium, or large.
- **Measurement Text Color:** Sets the text color for measurement notations.
- **Tag Text:** Provides an additional label to the right hand corner of the rendering window.
- **Date Format:** Current date format for case information display.
- **Continuous View:**
  - Checked – Switching between view presets for volume renderings will show intermediate volume positions.
  - Unchecked – Switching between view presets will not show intermediate positions; the volume will “jump” to the final position.
- **Make Text Annotations Global:** When checked, previously placed or new text annotations added to any 2D slice view except group slices (TMJ, ArchSection) will be visible when scrolling past the slice the measurement was placed on.
- **Cycle 2D Distance Measurement Color:** Measurement colors will cycle with every measurement that is added.
- **Enable Multiple Distance Measurement Mode:** Distance Measurement will become a toggle on/off button for measurement mode. Toggling “on” this mode will continue to pick beginning and end points for linear measurements with each click after the first measurement has been created.
- **Tabs:** This section determines which tabs are seen by the user when the program is running. Checked boxes will be available while unchecked boxes will hide those tabs. Changes are made after restarting the program.

- Auto save 2D view setting on application exit: This setting will determine if 2D view settings made in each of the applicable tabs will be saved automatically upon program closure and be reloaded with the next opened case. If left unselected, the user will have to manually save the configuration by clicking Save View Settings in the working tab. The specific 2D view settings that will be saved in each tab are given in the table below:

Section	Rendering presets, custom Brightness/Contrast (if the Dental preset is chosen), Sharpen Filter, Volume Clipping, Slice Thickness
Implant	Layout, Restoration Lock, View Preset, Brightness/Contrast, Sharpen Filter, Volume Clipping, and Remove Crown
ArchSection	Slice Interval, Cross Section Width/Interval/Thickness, Auto R-L, Pano Image Type, Pano Ruler Enabled, Brightness/Contrast mode, Layout (including Axial vs. Cross Series and Print Layout), Sharpen Filter, Color Preset, Nerve Diameter, and Nerve Visibility
TMJ	Lateral Width/Interval/Thickness, Pano Ruler, Brightness/Contrast mode and settings, Layout (including sequence type and Print Layout), Sharpen Filter, Color Preset, Focal Trough Thickness and Symmetry, Pano Render Mode

## Volume Rendering Preferences

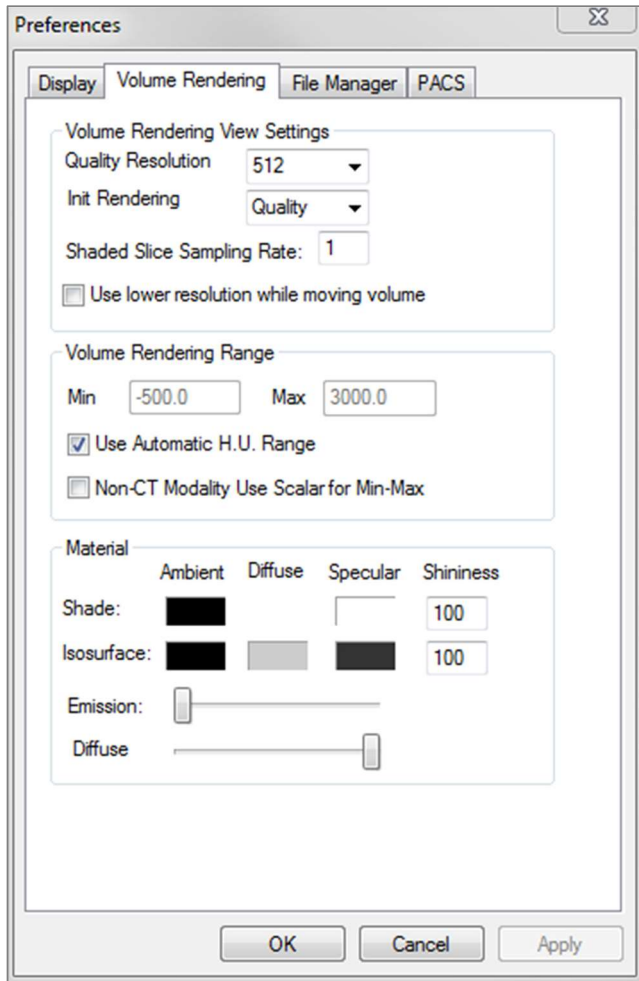

### Material

- Various properties can be adjusted to change the appearance of a volume rendering. Ambient, Diffuse, and Specular effects can be rendered in different colors.
- The degree of Emission and Diffuse can be adjusted with the respective sliders.
- Shininess is set to a number – higher numbers denote less shininess.

### Volume Rendering View Settings

- **Quality Resolution:** Sets the limit for the resolution of the image. This can be set to either a user-defined number or set to Unlimited.
- **Init (Initial) Rendering:** Sets the rendering quality upon opening Invivo.
- **Shaded Slice Sampling Rate:** Accepts a numerical value that sets the sampling rate to improve image quality at the cost of performance.
- **Use lower resolution while moving volume:** Positional changes of the volume will be rendered at a low quality resolution while maintaining the quality resolution setting in the final position.

### Volume Rendering Range

- The user can define the range of Hounsfield Units that will be rendered. This cannot be set when “Use Automatic H.U. Range” is checked.
- Checking “Non-CT Modality Use Scalar for Min-Max” will allow the user to define the minimum and maximum scalar units that will be rendered.

## File Manager Settings

### File Type-Associated Folder Paths

Folder paths can be set for each of the Invivo and DICOM file type options. When one mode is selected, the program will use the file paths associated with that file type mode, but the user may still save or open either file type at any time.

### File Path Preferences for Different Users

In the situation that there are multiple users on a single computer with Invivo5 installed across multiple user accounts, the file paths for all new accounts will initially take on the preferences defined by the user administrator account. Non-admin accounts may redefine their file path settings, but they will be overwritten the next time the settings are changed on a user administrator account.

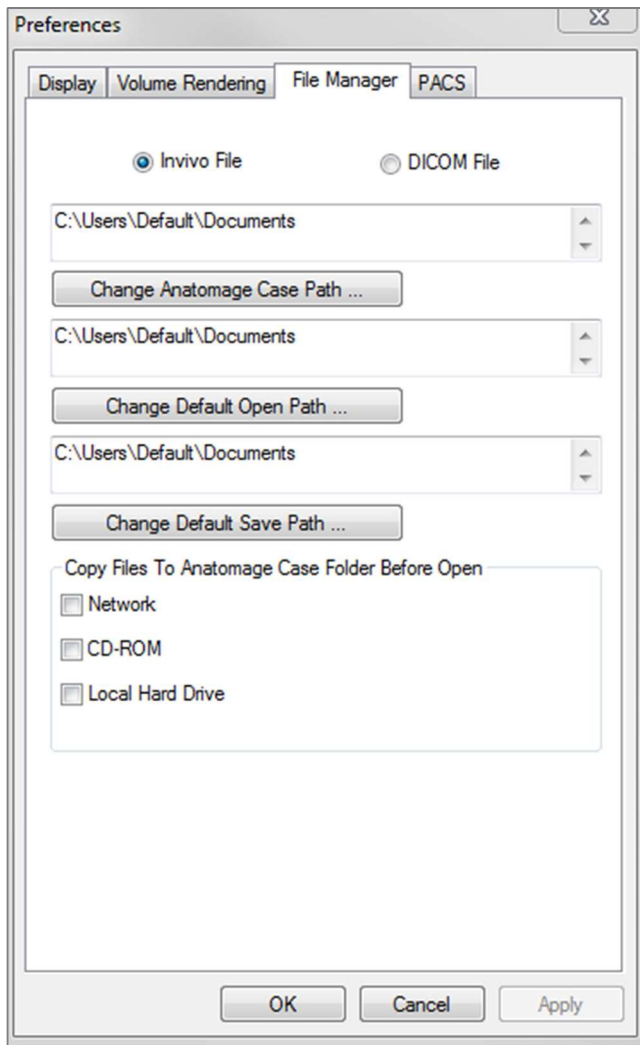

### File Paths

- Anatomage Case Path: Starting the program will open a window showing a list of cases within this location.
  - Can also serve as a backup folder for all opened cases.
- Default Open Path: This is the starting location for attempting to open a case through File → Open in the Menu bar.
- Default Save Path: This is the starting location for saving a case file in Invivo.

### Copy Files to Anatomage Case Folder Before Open

- This section allows the user to save a copy of a case that is to be opened in the Anatomage Case Folder if it is in any location besides this folder, such as on a different location on a network, on a CD-ROM, or in a different folder on the local hard drive.

## PACS Settings

The screenshot shows a 'Preferences' dialog box with four tabs: 'Display', 'Volume Rendering', 'File Manager', and 'PACS'. The 'PACS' tab is selected. It contains two sections: 'Import Configuration' and 'Export Configuration'. Each section has four text input fields: 'AE Title' (with 'Server' in the first), 'Host Name' (with '192.1.1.1'), 'Port' (with '100'), and 'AE Title' (with 'Client'). Below each section is a 'Configure' button. At the bottom of the dialog are 'OK', 'Cancel', and 'Apply' buttons.

### Import Configuration

- **Configure:** Click to edit the server and client information from which cases will be imported.

### Export Configuration

- **Configure:** Click to edit the server and client information to which cases will be exported.

# Basic Features

*The following is a detailed explanation of the various features provided by Invivo.*

## DICOM & Invivo File Loading with the File Manager

To open a DICOM data set or Invivo-associated file type (.inv, .amg, .api), first launch the Invivo software. The File Manager will appear upon startup, allowing you to open the data. If you installed Invivo with PACS mode please refer to page 28.

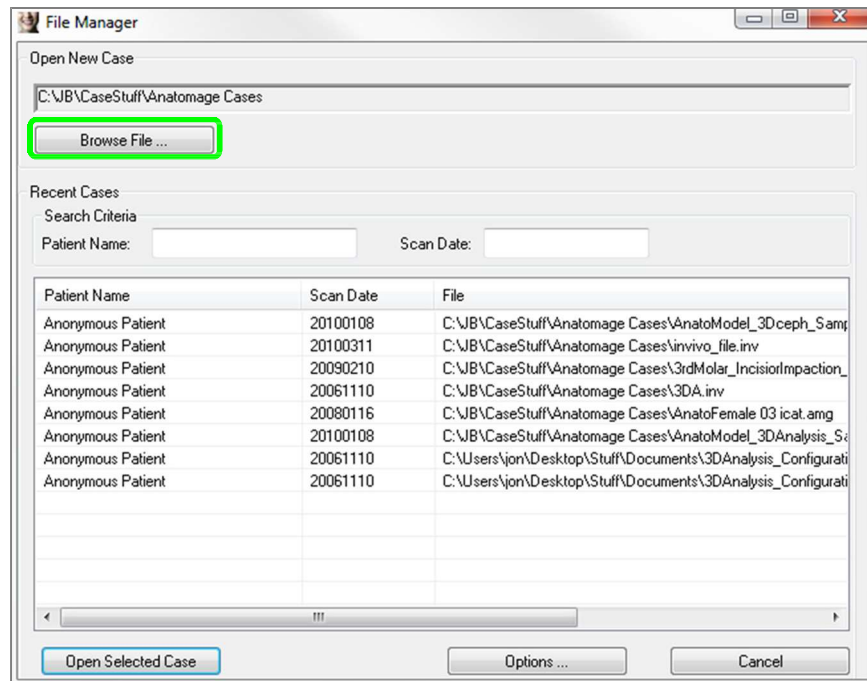

Click the Browse File button to search manually for the data you would like to open. If you are opening DICOM data, as shown to the right, simply highlight one of the .dcm files and click Open. It does not matter which DICOM file you choose, just click one and the software will open all the files within the data set present in that folder. If you are opening an Invivo file just click it and press Open. Invivo files can also be compressed and opened.

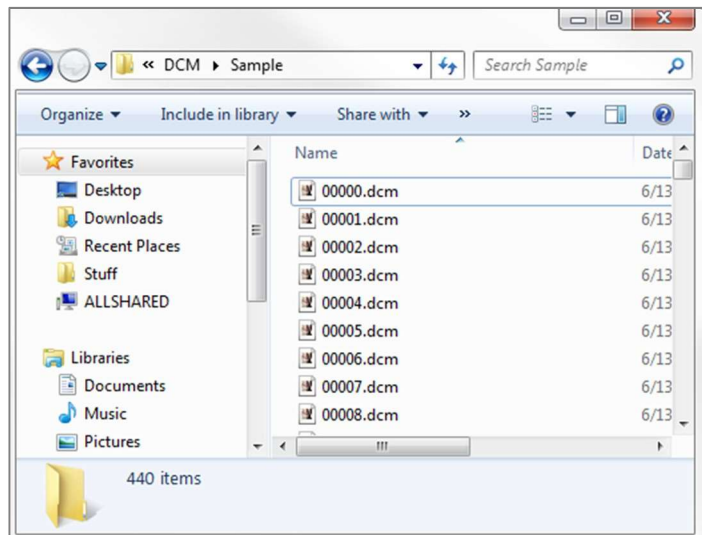



The File Manager allows you to automatically store and reopen recently viewed cases. This allows for quicker access to cases. By default, files will be saved in the “Anatomage Cases” folder, located in “My Documents.” This location can be changed in the Menu Bar → File → Preferences → File Manager.

Invivo allows you to quickly search through your recent cases by typing in the Patient Name or Scan Date in the search fields (shown right). You can also remove the selected Recent Cases from your Recent Case List by selecting the Options... button and using the additional boxes (shown below). This will also allow you to completely clear your Recent Cases list.

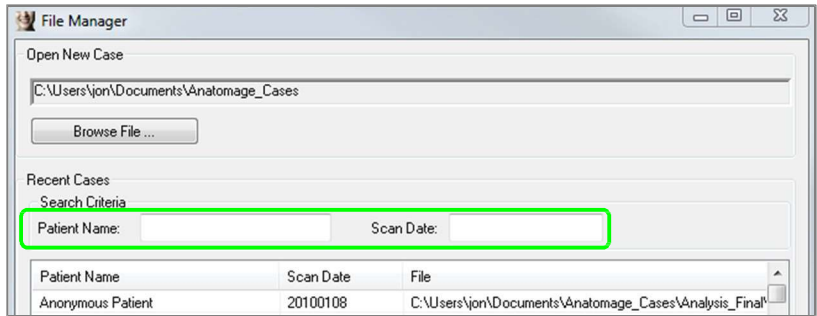

If you close a case and want to reopen another one, click on “File” → “Open” and the File Manager will appear again.

Selecting Options... will display additional options to delete the recent case history or to delete select cases from the list. This will only modify the cases that are displayed on the File Manager and does not delete the actual files from where they are saved.

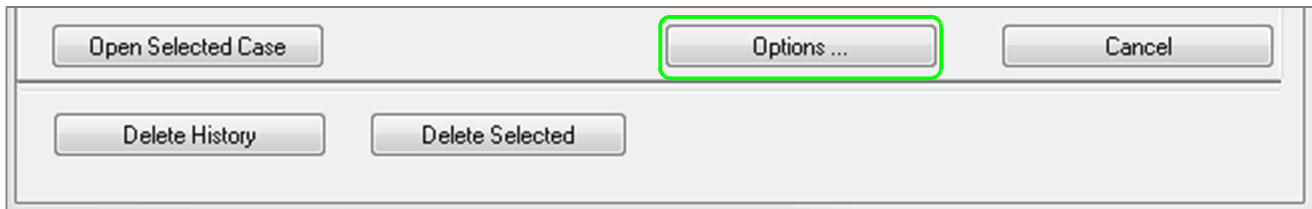

## Invivo/DICOM File Saving

Invivo provides four options for saving and each type differs in the size of the saved file and its compatibility with other software. Choosing “File” → “Save As...” for any file will present the dialog on the right. Choosing “File” → “Save” when a DCM file is open will save an INV in the specified location or simply overwrite the same file if it is of the INV file type.

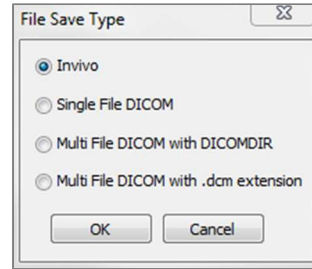

### Invivo

The following work can be saved as an Invivo file (.inv).

- Case Information & Patient Orientation
- Traced Nerves
- Implants & Implant Measurements
- Volume Measurements, Landmarks, and Annotations
- Images captured within the Gallery
- Sculpting Operations
- †Models imported from MDStudio
- †Tracings performed in 3DAnalysis

†These functions require the installation and activation of additional software modules.

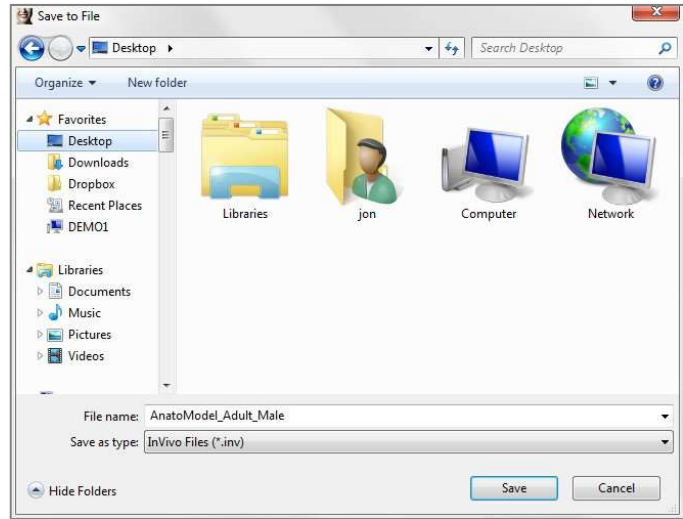

Click “File” → “Save As...,” browse to the folder you would like to save, name the file (default is the patient’s name), then click Save.

The following save dialog box will show up. Select the default “Full” option for saving everything without losing any information.

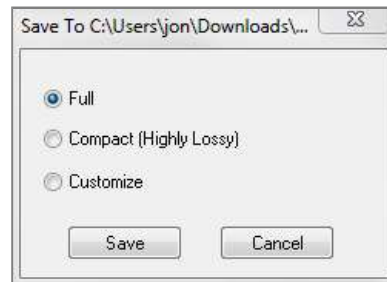

### DICOM

When the DICOM file type is chosen, the output options are either a single lossless DICOM or a multi-file DICOM (with DicomDIR) accompanied with an Invivo workup file containing workup data and a folder of exported Gallery images in DCM format.

For single-file DICOMs (Figure 1), the save dialog will ask for a location to save the files. For multi-file DICOMs (Figure 2), you will have to create or choose a folder to save the slices and DicomDIR file. The DicomDIR file presents the directory of slices to Invivo to accelerate the loading speed.



Figure 1: Single-file DICOM Save Dialog

The DICOM File Save Option dialog (Figure 3) will present numerous options for saving the file. Compression will reduce the size of the file (at the cost of increased saving and loading speed), “Lossless” or “Lossy” determines the quality (amount of data) of the file that is saved. Resampling will change the resolution by a factor in each orthogonal plane. The workup file description will be used to differentiate between workup files on PACS.

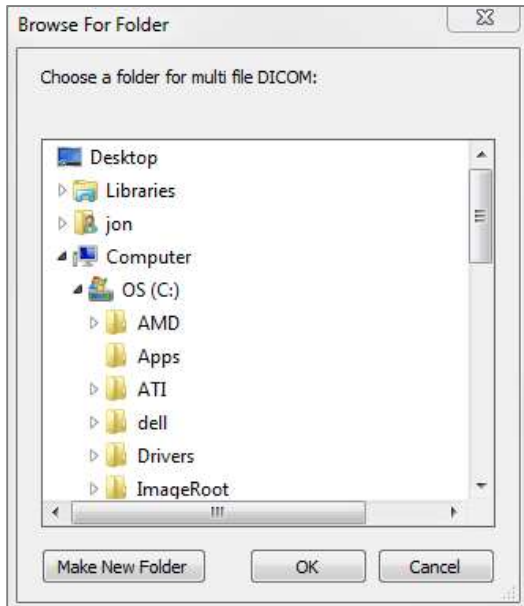

Figure 2: Multi-file DICOM Save Dialog

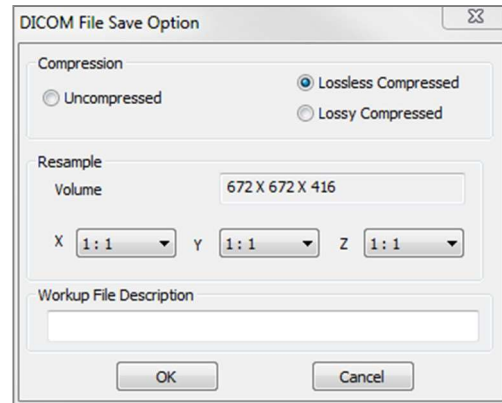
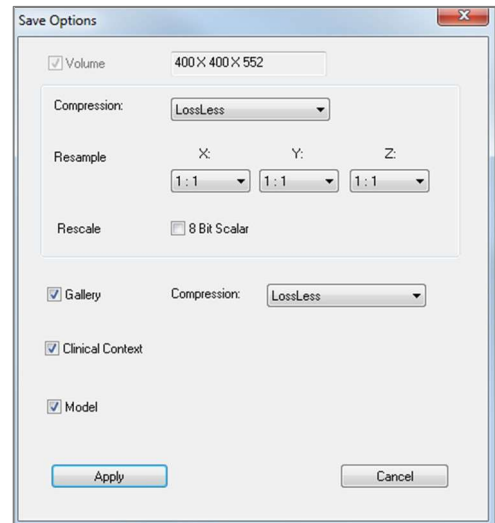

Figure 3: DICOM File Save Options

## Custom Saving Dialog

Available for Invivo file saving: By selecting the “Customize” option, the custom saving dialog shows up. In the dialog box, one can compress the data. For the main volumetric image, you can select to save it as “LossLess” or “Lossy” compression. With LossLess compression, the volume is compressed to about 1/3rd – 1/4th of the original size. With the Lossy compression option, the file size can be dramatically reduced, but the image is altered. Resampling the data will greatly reduce its size by combining voxels to reduce the overall voxel count. Rescaling the image will reduce the number of shades of gray in the image. You can also choose to selectively compress images in the gallery, the clinical content (such as implants and nerve tracings), and the models.



Warning: Saving files in lossy format degrades image quality.

## Saving As an Invivo Project File

Click “File” → “Save As Project...” to save the case as an APJ, Invivo Project file. This file will only save changes made to the original scan data. It requires a reference data (.dcm scan data or .inv file) when opening. If Invivo cannot locate the reference data, it will ask you to locate the data again. Because it is saving only the changes to the original, APJ files save much faster than full INV files.

## DICOM File Loading with PACS

If you chose to install the PACS mode of Invivo, upon launch, the PACS File Import window will open instead of the File Manager. At initial launch, the settings will need to be configured to connect with the database, but this information will be retained subsequently.

Without installing under PACS mode, this interface can still be accessed by choosing “File” → “Import PACS.”

### PACS Configuration

Click Configure to set up the connection to PACS. Input the appropriate server data and test the connection to verify the information.

Scans from PACS will be stored locally in the Local Storage Directory folder while they are open. The option to delete the files locally after opening them is available.

Transport Layer Security (TLS) setup can also be configured.

Once the information is complete, click OK. This data will be saved until manually reconfigured.

### PACS File Loading

Click Query to load the cases stored on PACS. Filter cases using the patient information fields. Select a case from the Case List and click OK. Invivo will search for any workup files associated with the patient. Select an existing workup file and click OK or click Cancel to open the raw patient scan.

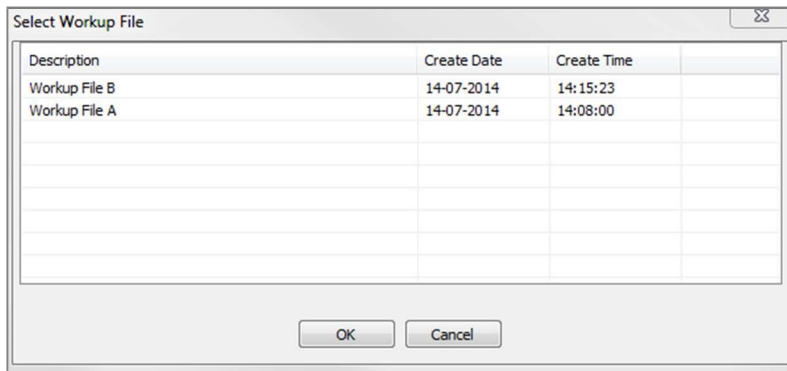

### PACS File Saving

Click on File → “Export PACS” to save the file onto PACS.

- Configure: Opens the PACS Configuration dialog.
- For descriptions of the different DICOM types, refer to page 26.
- Without installing under PACS mode, this interface can still be accessed by choosing “File” → “Import PACS.”

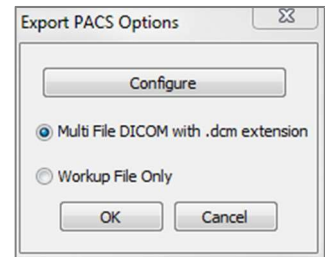

### Lay Egg

This function will create an executable file containing the 3D volume data from the scan that is currently open as well as a 2D Invivo viewer program. This function is designed to allow the sharing of scan data from an Invivo user to a non-Invivo user on shareable media such as a CD, DVD, or flash drive. Note that some antivirus programs may detect the file as a virus due to its executable format.

EggViewer: Running this file will initialize the viewer program and then load the embedded scan data. The EggViewer contains some Section, ArchSection, and Gallery functionality.

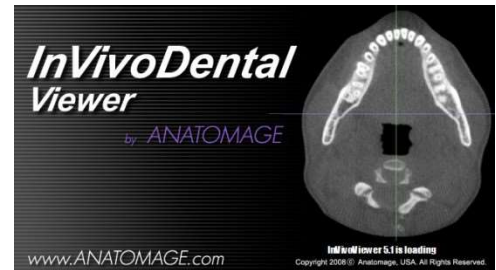

### Export to CD

This function will export the currently opened scan as a compressed or uncompressed DICOM or a full, compressed, or customized setting Invivo file. The exported file will be placed in the temporary burn location in the computer.

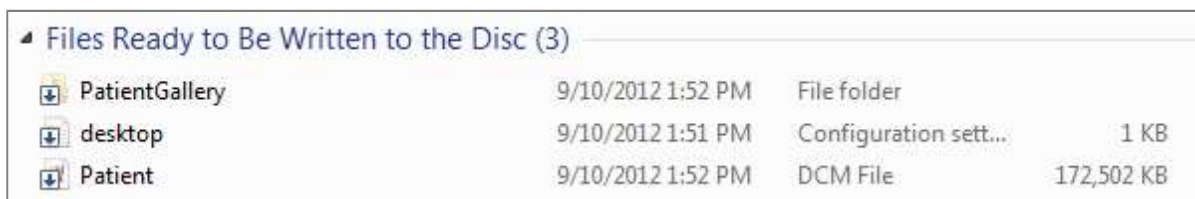

## Case Information Display

To display or hide the Case Information for a specific patient, go to the “File” → “Case Info.” Click Anonymize then click OK to save the changes.

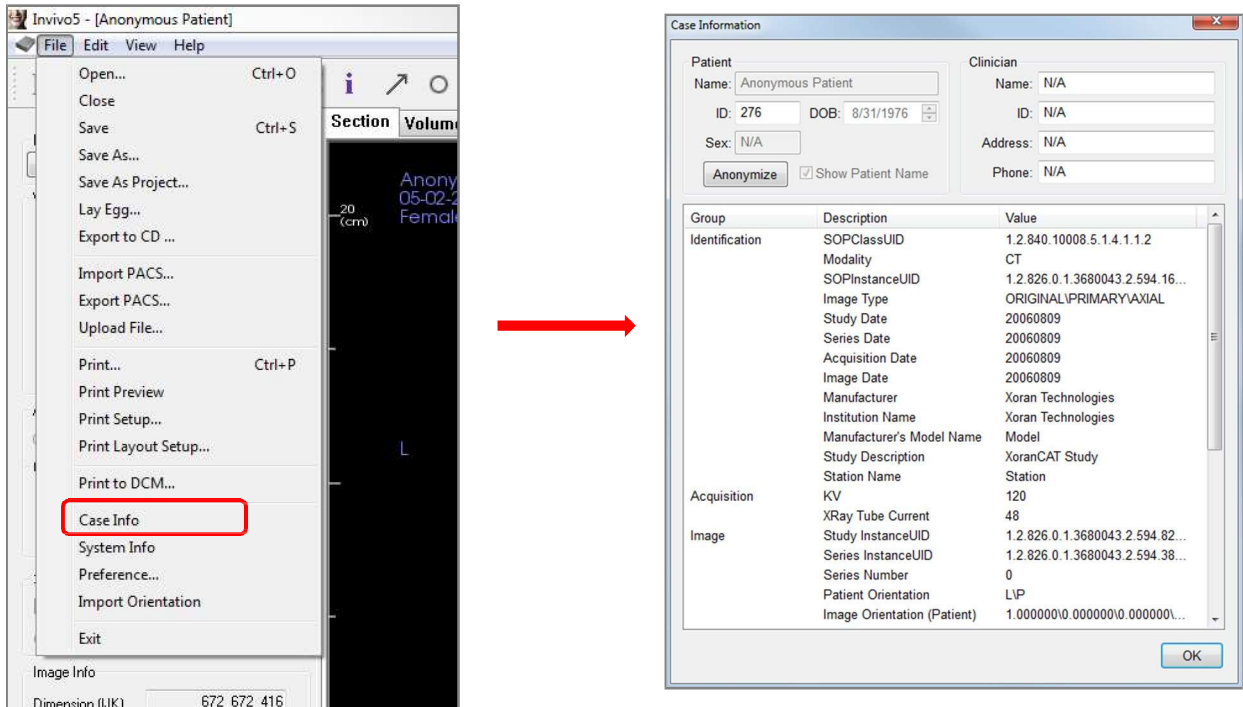

## Image Capture to File

To capture an image of the active display to file, click “View” → “Capture to File.” Browse to the location where you want to save the image, type the name of the file, choose the file type on the “Save as type” drop-down, and click Save. The file can be saved as bmp, jpg, or png format. Jpg is the most popular file format for images, but there is a small amount of color degradation. Bmp preserves the image, but the file size is big. Png is an effective lossless format that does not degrade the color.

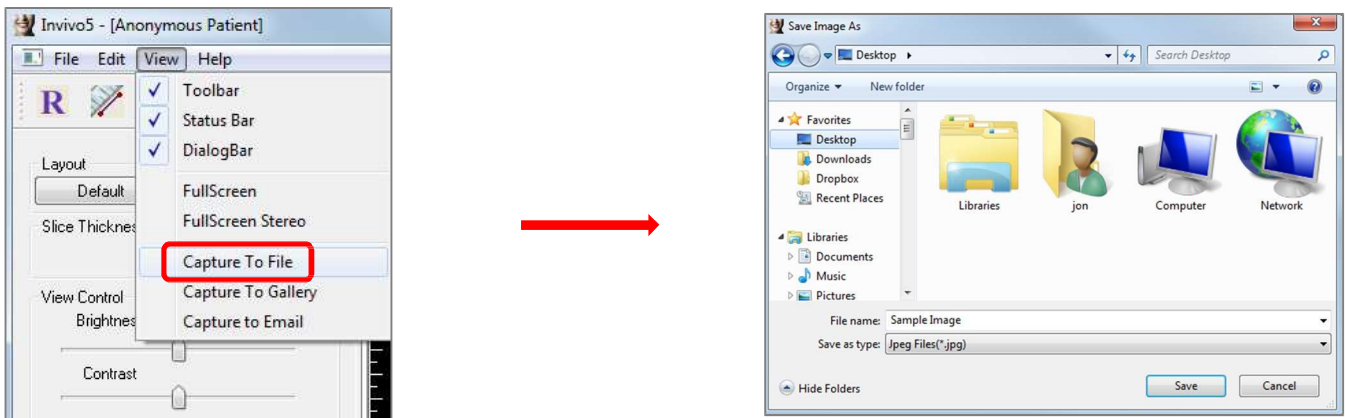

## Image Capture to Gallery

Selecting “Capture To Gallery” will capture an image of the rendering window and save it to the Image List (see Gallery Tab features for additional information, pg. 117).

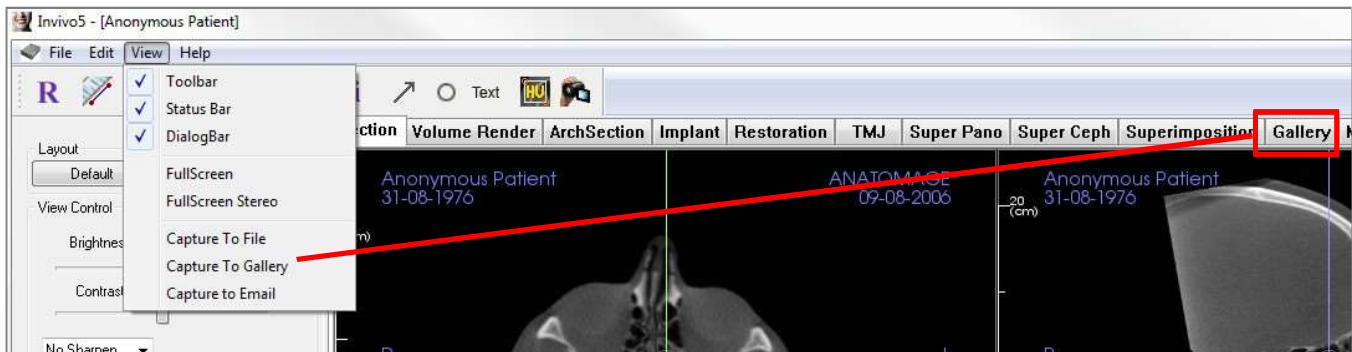

## Image Capture to an Email

Selecting “Capture To Email” will capture an image of the rendering window and attach it to an email ready to send. This tool requires e-mail client setup before use (ex: Microsoft Outlook, Mozilla Thunderbird).

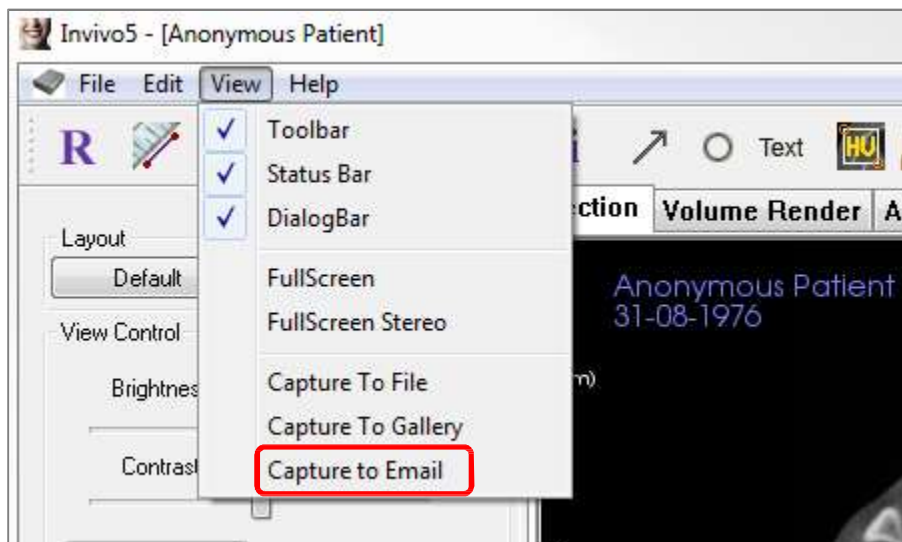

# Image Navigation

*Below is an explanation showing how to manipulate images in the rendering window with the keyboard and mouse.*

## Slider Scroll

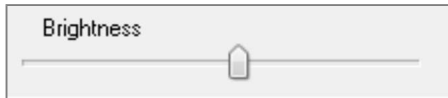

- Click the mouse cursor over any slider (e.g. axial slice, brightness, etc.) and move it to adjust the image.
- Click the slider and keep the mouse cursor in the Control Panel before scrolling the mouse wheel forward or backward to achieve the image adjustment you like.

## Zoom In/Out

- Place the mouse cursor in the center of the image you want to zoom.
- Hold down the “Control” key + left-button on the mouse.
- While holding down the buttons indicated above, move the mouse up and down on the screen.
- This shrinks/enlarges the image: Down vertically zooms out. Up vertically zooms in.

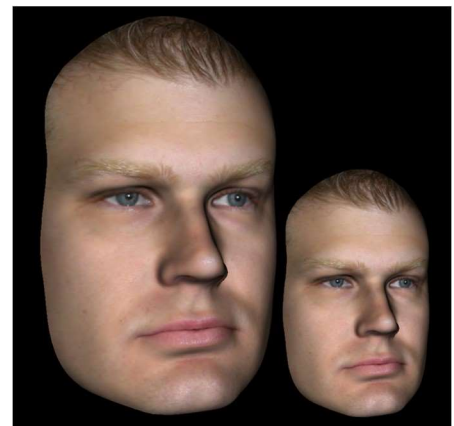

## Pan (Shift)

- Place the mouse cursor in the center of the image you want to shift.
- Hold down the “Shift” key + left-button on the mouse.
- While holding down the buttons indicated above, move the mouse any direction to achieve the desired image displacement.





## Free Rotate

*Applicable only for 3D images.*

- Place the mouse cursor in the center of the image you want to shift. Hold down the left-button on the mouse.
- While holding down the left-button, move the mouse in any direction to achieve the desired rotational position.

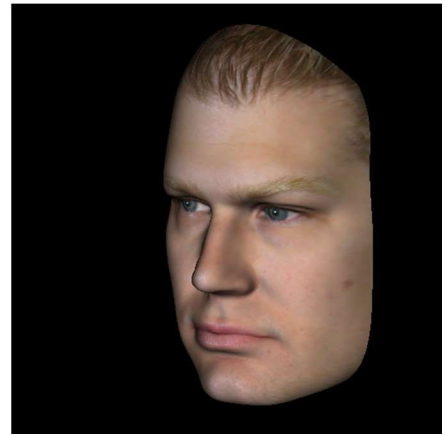

## Free Rolling

*Applicable only for 3D images.*

- Hold down the “Space” key + left-button on the mouse.
- While holding down the buttons indicated above, move the mouse up and down to rotate the image about a central axis.

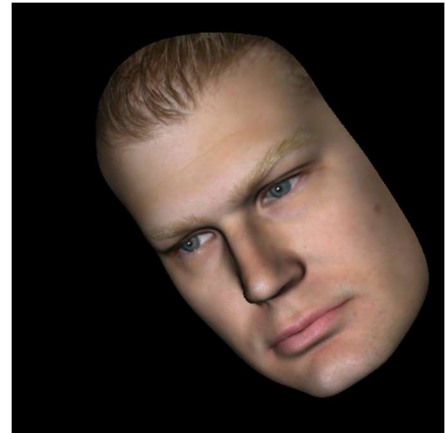

## Increment Rotate

*Applicable only for 3D images.*

- Use the keyboard arrows ← ↑ ↓ → to rotate the 3D Model 1 degree up, down, right, or left, perpendicular to the computer screen.

## Increment Roll

*Applicable only for 3D images.*

- Hold down the “Control” key and use the keyboard arrows ← → to rotate the 3D Model 1 degree rolling left or right about a central axis. Pressing ← → without the Control key pressed will roll the image left or right. Use ↑ ↓ to roll the image up or down.

## Anatomical Plane Clipping

*Applicable only for 3D images.*

- Place the mouse cursor over the center of the image, then scroll the mouse wheel forward or backward to clip the anatomic plane as you like (after enabling clipping in the Control Panel).

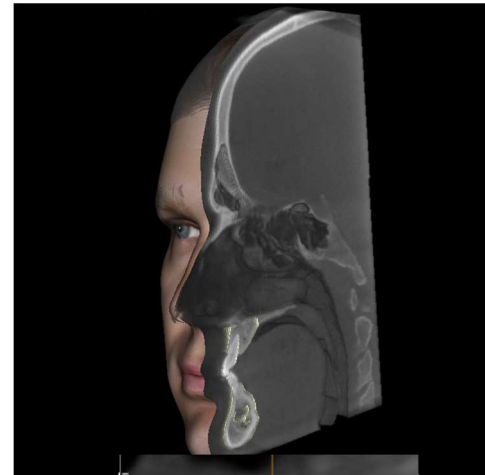

## Scroll Slice

Use when you would like to move through the series of sections when in either the Section, ArchSection, or Pano views.

- Place the mouse cursor in the center of the image then scroll the mouse wheel forward or backward to move one section at a time as you advance through the data slices.

*Note: In the ArchSection Tab, you must first create an arch spline to activate this feature.*

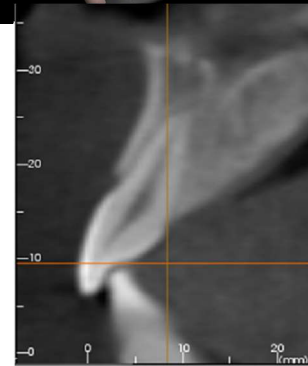

## Move/Rotation Widget

- Superimposition View: Click on either the ring or the arrows circling the patient and move it in the direction you want the patient to be oriented.
- Model View: Use to move a model through a portion of the volume for simulation creation. Click on either the ring or the arrows circling the model and move/rotate it in the direction you want it to move.

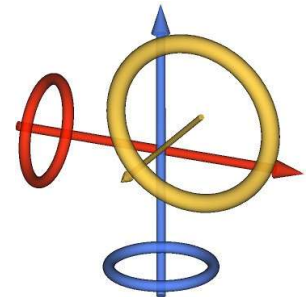

## 3D Restoration Widget

The 3D Restoration widget is designed to maximize visibility in the renderer and provide a high level of versatility in crown positioning and sizing. The resizing handles only appear when the camera perspective is within a range of angles that is relatively orthogonal to it.

- The rotation circle appears on the same plane as the two resizing tools that are close to orthogonal to each other and the camera perspective and feature eight arrows for rotation.
- The red resizing handle can be selected and dragged toward/away from the crown to reduce/expand the mesiodistal size of the crown.
- The green resizing handle can be selected and dragged toward/away from the crown to reduce/expand the height of the crown.
- The blue resizing handle (not shown) can be selected and dragged toward/away from the crown to reduce/expand the buccolingual size of the crown.
- The crown can be clicked and dragged freely along a plane orthogonal to the camera angle.

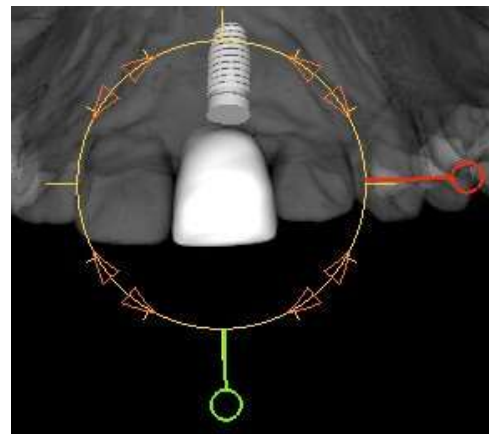

# Full Screen Mode and Keyboard Shortcuts

*Below is an explanation pertaining to running the software in full screen mode without toolbars and controls.*

## Switching to Full Screen Mode

From the software menu, select “View” → “Full Screen.” “Full screen stereo” is only applicable for the stereo display system. To return to the normal screen mode, press the “Esc” key on the keyboard. Full screen is not applicable to the ArchSection Tab and Implant Tab.

## Keyboard Shortcuts at Volume Rendering View

The following keyboard shortcuts are available in the Volume Render view:

Category	Keyboard Shortcut	Description
View Preset	<i>1</i>	Inverse Volume Rendering
	<i>2</i>	Soft-Tissue 1
	<i>3</i>	Soft-Tissue 2
	<i>4</i>	Soft-Tissue + Bone 1
	<i>5</i>	Soft-Tissue + Bone 2
	<i>6</i>	Teeth
	<i>7</i>	Bone
	<i>8</i>	(unassigned)
	<i>9</i>	(unassigned)
	<i>0</i>	Gray Scale
Clipping Control	<i>P</i>	Toggles clipping plane on/off
	<i>A</i>	Axial clipping set
	<i>S</i>	Sagittal clipping set
	<i>C</i>	Coronal clipping set
	<i>F</i>	Flip the clipping direction
	<i>Page Up / Page Down</i>	Move the clipping plane
	<i>Q</i>	Open Free-Sculpt Tool
	<i>W</i>	Open Point-to-Point Sculpt Tool
Copy/Paste	<i>Ctrl+C / Ctrl+V</i>	Text/Circle/Arrow notations can be copied and pasted
Delete	<i>Del</i>	Pressing this key will delete the selected measurement, comment marker, notation, airway volume, or nerve

# The View Tabs:

## Section View Features

*The Section View Tab gives the ability to view the X, Y, and Z sections (axial, coronal, sagittal) and user-created, custom sections simultaneously for 2D visualization, measurements, and the utilization of several image enhancement features. Invivo also integrates 3D functions in the Section View Tab.*

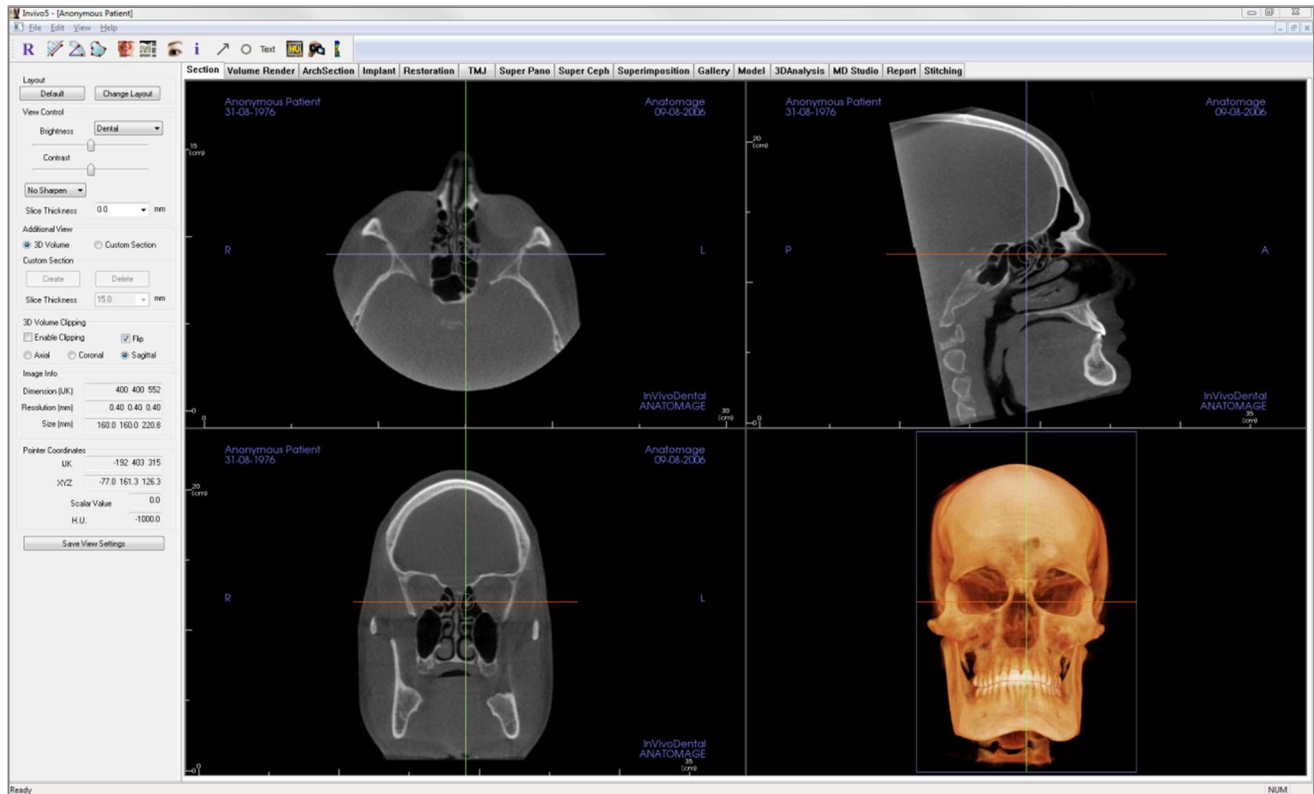

## Section: Toolbar

Shown below are the Toolbar and tools that are loaded with the Section View Tab:



**Reset View:** Resets the rendering window to the original view size.



**Distance Measurement:** After selecting this tool, click two points to mark the desired distance. A number in millimeters will automatically display. Click on the measurement and press the “delete” key to delete it.



**Angle Measurement:** After selecting this tool, click the first point, then click the vertex, then click the last point to create an angle. A number in degrees will automatically display. Click on the measurement and press the “delete” key to delete it.



**Area Measurement:** After selecting this tool, click multiple points along the boundary of the desired area. Double-click or right-click to end the measurement. A number in millimeters squared will be automatically display. Click on the measurement and press the “delete” key to delete it.



**Reorientation:** Click this button to re-orient the image. A circle will show up in each section. Grab the arrow widgets and rotate the image to the desired orientation.



**Layout:** Creates a different layout to your preference. After clicking on the layout icon, a list of various layout options will appear. Click on the layout of your preference to apply it.



**Toggle Cursor Visibility:** Turns cursor on and off.



**Information Display:** Displays or hides case information embedded in the data.



**Arrow Notation:** Allows an arrow to be drawn on the image.



**Circle Notation:** Allows a circle to be drawn on the image.



**Text Notation:** Allows text to be written and edited on the image.



**H.U. Measurement:** Calculates the HU value of an area within a bounding box. The measurements will display alongside the rectangle and can also be repositioned by dragging. The information updates when the box is moved or if the user scrolls.



**View Sequence:** Allows for the creation of custom camera sequences and AVI file movie capturing. Refer to the Volume Render View Sequence section (pg. 52) for additional information and description.



**Airway Measurement:** This button will open the airway volumetric measurement interface. More details can be found in the Airway Measurement section (pg. 42).



**Warning:** Any measurement that is incorrect can lead to surgical complications if diagnosis, treatment plans and/or actual treatment is based on the incorrect measurements. It is critical for the end user to learn how to perform measurements correctly and employ proper usage of all measurement tools. Measurement accuracy depends on the image data and the hardware scanner that generated the image data. The measurement cannot be more precise than the resolution of the image. Software reports the value based on user-picked points. Due to the nature of medical imaging, the boundary is not always well defined. The apparent boundary depends on the current brightness and contrast setting. The boundary may shift as the user makes adjustments to brightness and contrast. The user must understand the limitation of the measurement value before applying to the patient. If you notice any inconsistencies or software problems with measurements, or have further questions or concerns about using measurement tools correctly, please

contact us at (408) 885-1474 or email us at [info@anatomage.com](mailto:info@anatomage.com)

## Section: Control Panel

The Control Panel interface is organized into several sections:

- Layout:** Includes 'Default' and 'Change Layout' buttons.
- View Control:** Features sliders for 'Brightness' and 'Contrast', a 'Dental' rendering preset dropdown, a 'No Sharpen' dropdown, and a 'Slice Thickness' dropdown set to 0.0 mm.
- Additional View:** Includes radio buttons for '3D Volume' and 'Custom Section' (selected), and 'Create' and 'Delete' buttons. The 'Slice Thickness' dropdown is set to 15.0 mm.
- 3D Volume Clipping:** Includes an 'Enable Clipping' checkbox, a checked 'Flip' checkbox, and radio buttons for 'Axial', 'Coronal', and 'Sagittal' (selected).
- Image Info:** Displays 'Dimension (IJK)' as 400 400 552, 'Resolution (mm)' as 0.40 0.40 0.40, and 'Size (mm)' as 160.0 160.0 220.8.
- Pointer Coordinates:** Displays 'IJK' as -63 283 292, 'XYZ' as -25.4 113.3 116.8, 'Scalar Value' as 0.0, and 'H.U.' as -1000.0.
- A 'Save View Settings' button is located at the bottom.

### Layout:

- Default: Reset to the original layout.
- Change Layout: Click to choose custom layout.

### View Control:

- Brightness & Contrast: Can be adjusted for each of the presets to enhance your image.
- Rendering Preset (drop-down list): The presets either load a brightness/contrast setting that is optimized for a particular tissue type or a color preset.
  - Brightness/Contrast Presets: Dental (custom), Abdomen, Bone, Brain CT, Liver, Lung, Mediastinum, and Grayscale.
  - Color Presets: Allows better visualization of certain anatomic structures, soft tissue profiles, airway, etc. The color rendering is only for visualization. **The colors are based on densities but DO NOT represent the density value of the bone.**
- Sharpening Filter: Applies the selected sharpening filter from the drop-down menu to the 2D slice renderers.
- Slice Thickness: Uses ray sum when reconstructing the 3D image along each orthogonal plane.

### Additional View:

- 3D Volume: This option allows 3D volume rendering in the fourth corner of the window.
- Custom Section: This option allows for the creation of a custom section.

### Custom Section:

- Click Create to start a custom section. By clicking two points, a customized section can be created on any cross section to better visualize anatomy along that axis. The custom section can be navigated by clicking and dragging the arrows to rotate, the endpoints to lengthen, or the center point to drag the entire section freely.

- Delete: Removes the custom cross section made in the rendering window.
- Slice Thickness: Adjusts the slice thickness of the custom section. Slice thickness can also be adjusted using the circular handles flanking the center of the section.

### 3D Volume Clipping:

When 3D volume is enabled, this option allows you to clip the volume to see the internal anatomy. The clipping plane will be synchronized with section cursors.

### Image Info:

- Dimension, resolution, and field of view size are summarized.

### Pointer Coordinates:

- IJK or XYZ: coordinates give the user the ability to examine the coordinate of the cursor upon the absolute coordinate system.
- Scalar Value is the gray scale value of the voxel pointed by the cursor pointer. H.U. or Hounsfield unit, is an approximate value of the voxel calculated by “Rescale Slope” and “Rescale Intercept” in DICOM information. *H.U. value approximations may not be as accurate if your CT hardware calibration is off. Contact your hardware manufacturer for more information about H.U. accuracy.*

### Save View Settings

- Saves the current 2D View settings to be reloaded upon opening any case. See the Display Preferences section in Preferences (pg. 19) for more information on which settings are saved for this specific tab.



## Section: Rendering Window

This window allows viewing of the X, Y, and Z sections (axial, coronal, sagittal) and custom sections or a 3D view simultaneously. This allows the clinician to have very accurate 2D visualization and 2D measurements.

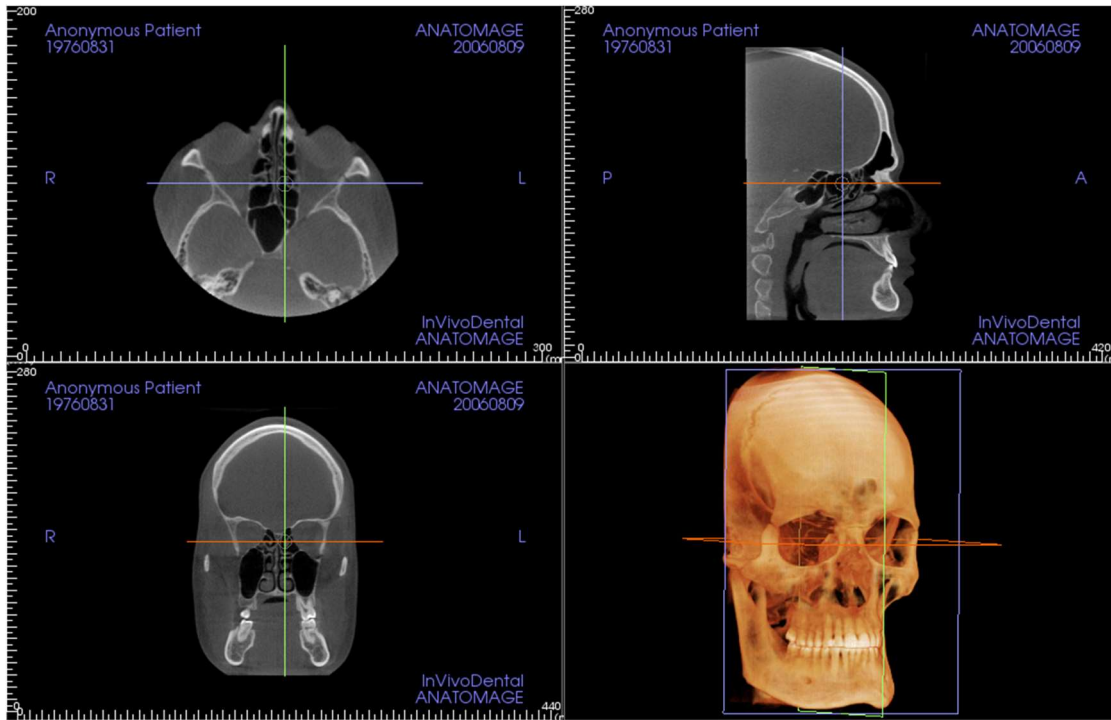

**Scroll wheel:** Move mouse pointer to the desired cross section. Use the scroll wheel to move the slice up and down.

**Cursor:** Grab one of the cursors (axial, sagittal or coronal). Move the cursor in the desired direction. The corresponding image will be updated.

**Center Circle:** Pick a point inside the center circle. Move the circle in the desired direction. The other two images will be updated.

**Zoom:** Click and hold the left-click mouse button on the image and the “Ctrl” key on the keyboard. Drag the mouse cursor up and down to zoom in and out.

**Pan:** Click and hold the left-click mouse button on the image and the “Shift” key on the keyboard. Drag the mouse cursor to move the image.

## Section: Airway Measurement



Airway Measurement: Selecting the icon will prompt the dialog box below. Click OK to continue.

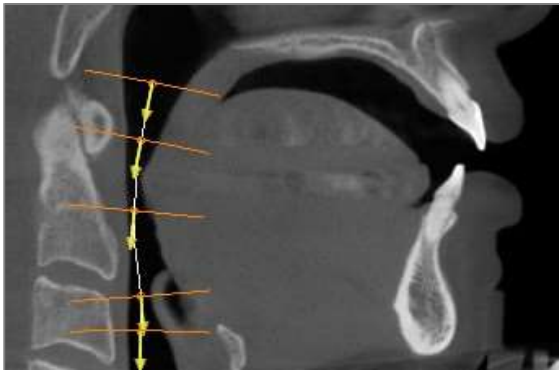
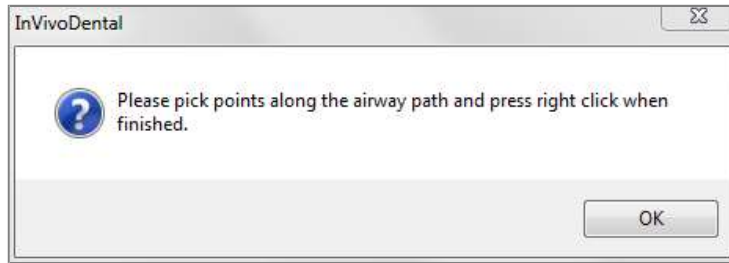

### Tracing the Profile:

- Use the scroll-wheel to locate the mid-sagittal plane.
- Pick points along the airway in the sagittal section to define your measurement path with the left-click button.
- Right-click when finished.

### Viewing the Volume Measurement:

- Invivo will convert your profile tracing into a volume rendering and superimpose it onto the scan data. An isolated airway can be examined in the variable window.
- The minimum cross-sectional area and total volume are displayed next to the airway measurement.
- Graphs of the RL and AP distance as well as the cross-section area are displayed. Individual values can be obtained by clicking on the graphs.
- The airway volume and measurement values can be deleted by left-clicking once on the airway, then pressing “delete” on the keyboard.

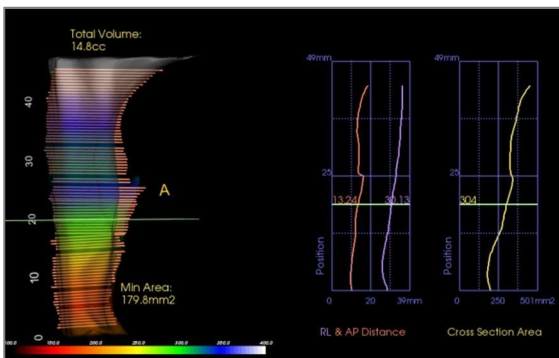

**Important:** The measurement values may not be true anatomical volumetric measurements. Due to the nature of the imaging, there are imaging artifacts such as white noise, scattering, beam hardening, ring noise or off scale H.U. The software measurement tool cannot distinguish the imaging artifact from the true anatomy. Furthermore, the measurement value depends on threshold values; thus, user must set proper thresholds to get the best estimate of the desired structure. The measurements must not be used as the sole metric for any treatment.



**Warning:** Any measurement that is incorrect can lead to surgical complications if diagnosis, treatment plans and/or actual treatment is based on the incorrect measurements. It is critical for the end user to learn how to perform measurements correctly and employ proper usage of all measurement tools. Measurement accuracy depends on the image data and the hardware scanner that generated the image data. The measurement cannot be more precise than the resolution of the image. Software reports the value based on user-picked points. Due to the nature of medical imaging, the boundary is not always well defined. The apparent boundary depends on the current brightness and contrast setting. The boundary may shift as the user makes adjustments to brightness and contrast. The user must understand the limitation of the measurement value before applying to the patient. If you notice any inconsistencies or software problems with measurements, or have further questions or concerns about using measurement tools correctly, please contact us at (408) 885-1474 or email us at [info@anatomage.com](mailto:info@anatomage.com)

## Section: Light Box

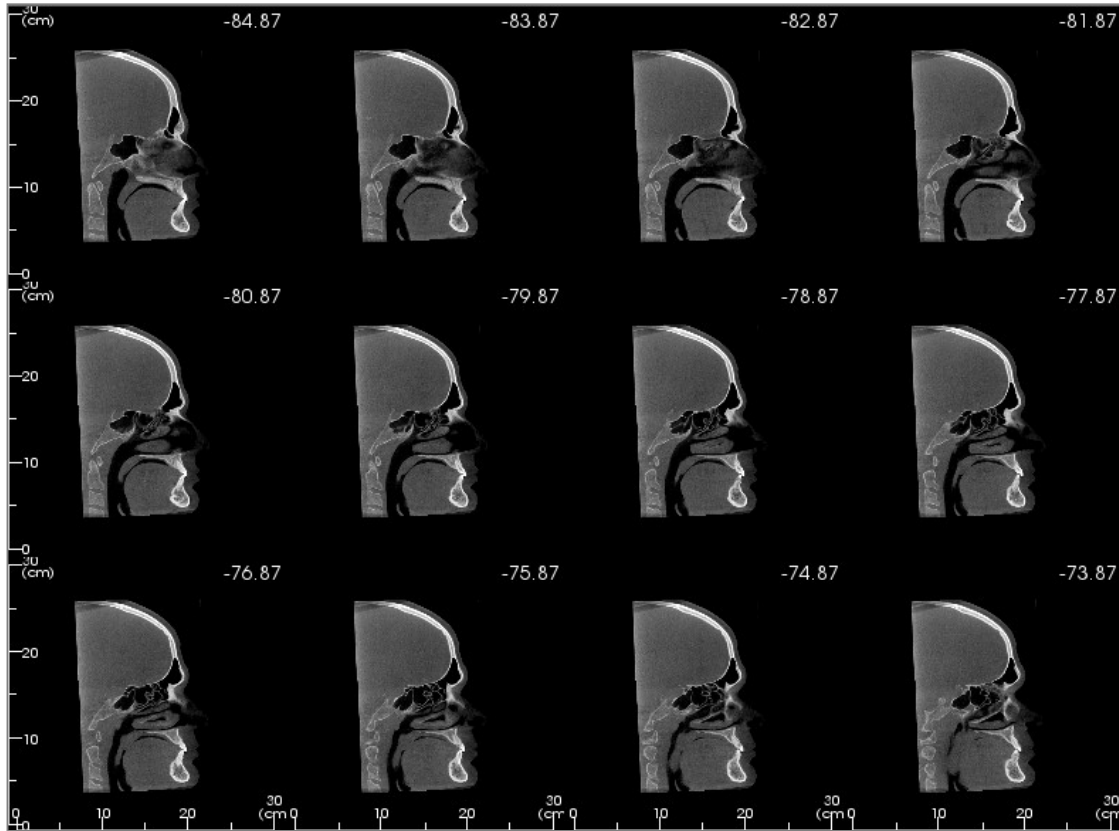

Change Layout has the option to change the Section view format to a “Light Box” style.

- The Light Box is composed of 4-32 sections of either axial, sagittal, or coronal views.
- The user may also define the Slice Interval by selecting a drop-down option between 0.1-20.0mm or by manually entering a number within that interval on the keyboard.

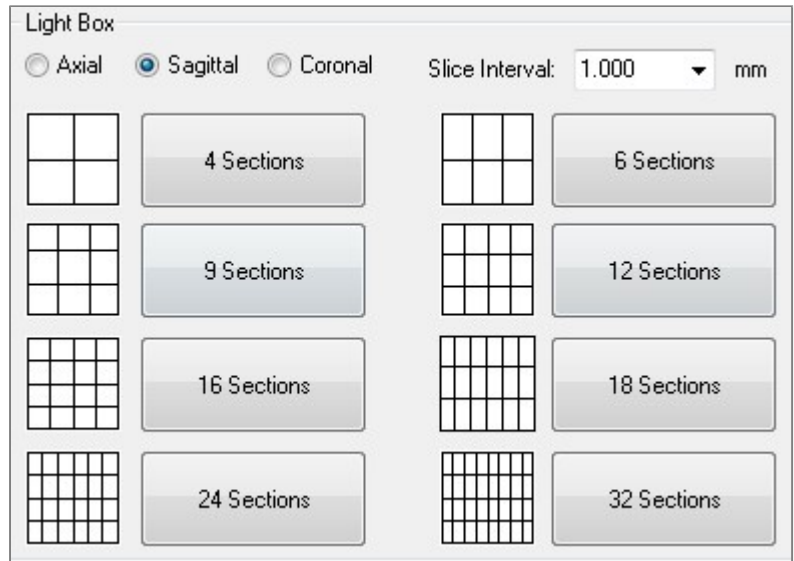

# Volume Render View Features

*The Volume Render Tab shows the patient in three-dimensionally reconstructed views and allows you to explore the internal structures and never-before-seen views of the patient.*

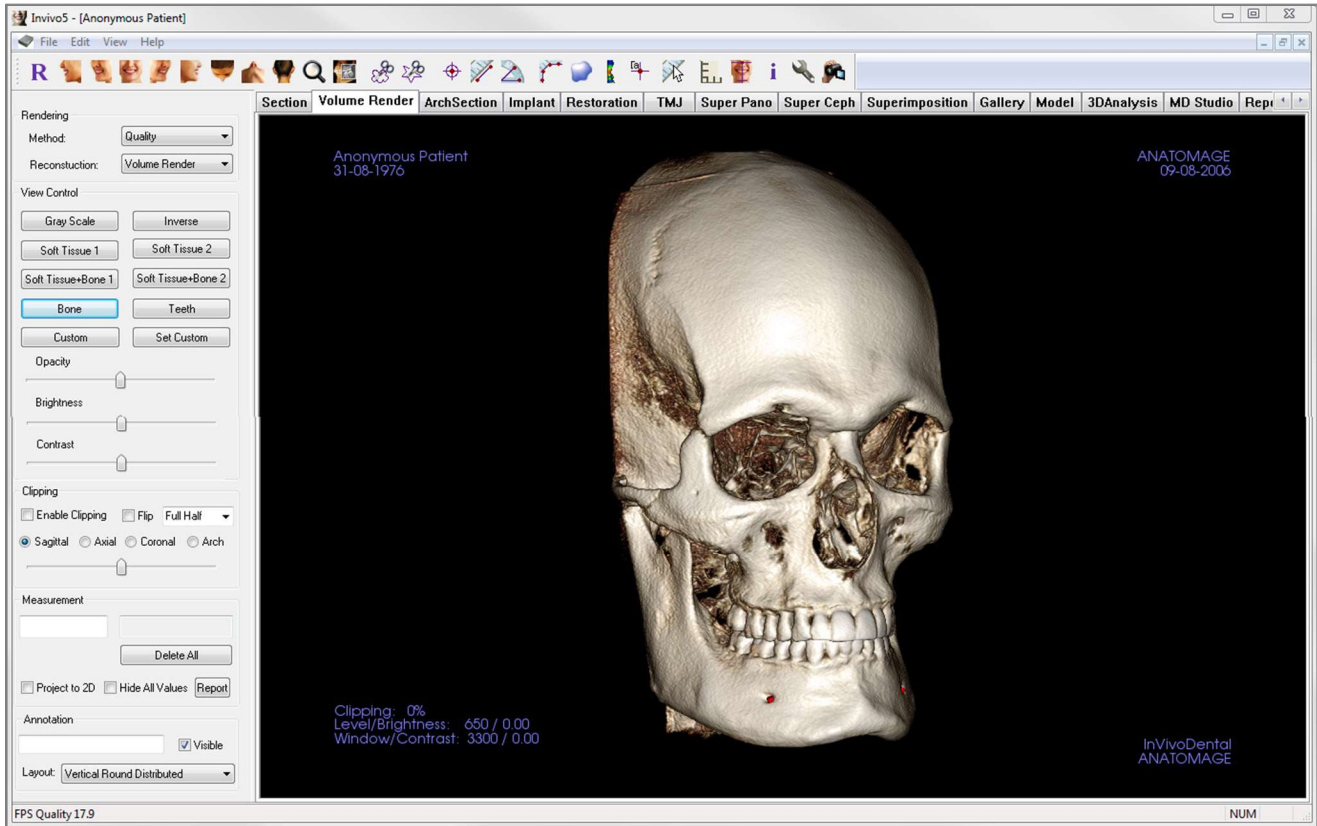

## Volume Render: Toolbar

Shown below are the Toolbar and tools that are loaded with the Volume Render View Tab:



Reset View: Resets the rendering window to the original view size.



Left View: Automatically orients the volume so the patient is facing left sagittal.



Left  $\frac{3}{4}$  View: Automatically orients the volume so the patient is facing 45° left sagittal.



Front View: Automatically orients the volume so the patient is facing the front.



Right  $\frac{3}{4}$  View: Automatically orients the volume so the patient is facing 45° right sagittal.



Right View: Automatically orients the volume so the patient is facing right sagittal.



Top View: Automatically orients the volume so you are oriented above the patient.



Bottom View: Automatically orients the volume so you are oriented below the patient.



Back View: Automatically orients the volume to the posterior view.



Quick Zoom: Click the zoom icon, then the point on the volume to zoom in. Use Reset View icon to go back to normal size.



Quick Slice: Once activated, clicking on a point on the volume will open a 2D zoom window in that location. The zoom window can be scrolled through using the mouse wheel.



Freehand Sculpture: Freely outline an area and remove the volume perpendicular to the plane of the screen. The volume inside or outside the selection can be chosen by clicking in the respective areas.



Polygon Sculpture: Outline an area by placing a series of points and right-clicking. The volume perpendicular to the plane of the screen will be removed. The volume inside or outside the selection can be chosen by clicking in the respective areas.



Marker: Select this option to mark a point on the volume and X,Y,Z coordinates (axial, sagittal, vertical) will appear. Clicking on the point and moving the cursor can modify points. Click on the point and press the “delete” key to delete it. Control Panel features allow the values to be hidden or exported to a report.



Distance Measurement: Select this option and mark two points on the volume and distance will appear. Clicking on the point and moving the cursor can modify points. Click on the measurement and press the “delete” key to delete it. Control Panel features allow the values to be projected to 2D, hidden, or exported to a report.



Angle Measurement: Select this option and mark three points on the volume and the angle between them will appear. Clicking on their control points and moving the cursor can modify measurements. Click on the measurement and press the “delete” key to delete it. Control Panel features allow the values to be projected to 2D, hidden, or exported to a report.



**Polygonal Measurement:** When selected, you may mark an unlimited number of points on the volume and the total between the first point and the last point will appear. Right-click your mouse to indicate that you have marked your last point. Clicking on the point and moving the cursor can modify points. Click on the measurement and press the “delete” key to delete it. Control Panel features allow the values to be projected to 2D, hidden, or exported to a report.



**Volume Measurement:** This button will open the volumetric measurement window.



**Airway Measurement:** This button will open the airway volumetric measurement interface. More details can be found in the Airway Measurement section (pg. 51).



**Comment Marker:** Pick a point in the volume and enter comments. Enter the text you would like to appear in the Insert Comment window and press OK.



**Quick Measurement:** Click to activate a ruler at the tip of the cursor. Click again to turn off.



**Grid:** Toggles between four different grid layouts for simple assessment of size, measurement, and spatial location.



**Patient Orientation:** Click to change patient orientation.



**Information Display:** Displays or hides case information embedded in the scan data.



**Setup View:** Allows option to view either parallel or perspective views in 3D. For Airway Measurement, you can set the threshold and displayed color range.



**View Sequence:** Allows for the creation of custom camera sequences and AVI file movie capturing. Refer to the View Sequence description in the Volume Render View section (pg. 52)



**Warning:** Any measurement that is incorrect can lead to surgical complications if diagnosis, treatment plans and/or actual treatment is based on the incorrect measurements. It is critical for the end user to learn how to perform measurements correctly and employ proper usage of all measurement tools. Measurement accuracy depends on the image data and the hardware scanner that generated the image data. The measurement cannot be more precise than the resolution of the image. Software reports the value based on user-picked points. Due to the nature of medical imaging, the boundary is not always well defined. The apparent boundary depends on the current brightness and contrast setting. The boundary may shift as the user makes adjustments to brightness and contrast. The user must understand the limitation of the measurement value before applying to the patient. If you notice any inconsistencies or software problems with measurements, or have further questions or concerns about using measurement tools correctly, please contact us at (408) 885-1474 or email us at [info@anatomage.com](mailto:info@anatomage.com)

## Volume Render: Control Panel

### Rendering:

You can select different methods of rendering to suit your needs.

- Method: “Performance” is fast but there are some rendering artifacts. “Quality” gives the highest level of detail, but response is slower. “Default” is in between the other two options.
- Reconstruction: There are three possible reconstruction methods: Volume Rendering, Maximum Intensity Projection, and X-ray.

### View Control:

- Color Presets: Gray Scale, Inverse, Soft Tissue 1, etc. allow better visualizations of certain anatomic structures, soft tissue profiles, airway, etc. This is achieved by displaying specific densities with specific colors.
- Opacity: Allows for the translucency/opacity to be adjusted.
- Brightness & Contrast: Can be adjusted for each of the presets to enhance the image.

### Clipping:

- Click the “Enable Clipping” box to slice the image along the predefined anatomical planes (sagittal, axial, coronal, and arch).
- Scrolling the mouse wheel or slider will move the clipping plane.
- To switch a view to the opposite side, click “Flip.”

### Measurement:

- Once landmarks or measurements are defined, the text can be edited in the edit box.
- Measurements can be projected as 2D values or hidden by clicking the appropriate box.
- Delete All will delete all measurements within the rendering window.
- Report exports the values and annotations to a .CSV file for viewing and/or performing computations as a spreadsheet.

### Annotation:

- Edits selected comment/annotation in the text field.
- You can toggle added comments on/off by selecting “Visible.”
- Layout: Sorts all added comments in the rendering window based on selected setting (Horizontal, Stick to Point, User Dragged, Vertical, Vertical Even Distributed, Vertical Round Distributed).

## Volume Render: Patient Orientation

The reorientation tool provides the user a way to orient the volume through each orthogonal view (sagittal, coronal, axial) using reference lines as well as to reset the image to the default coordinate system.

- After selecting the reorientation icon in the toolbar, left-click and drag each reference line to the approximate proper location on the volume (ex. Frankfort Horizontal in sagittal view).
- Left-click and drag the rotation handles to rotate the volume to match the reference line. Continue through each view until the desired orientation is achieved.

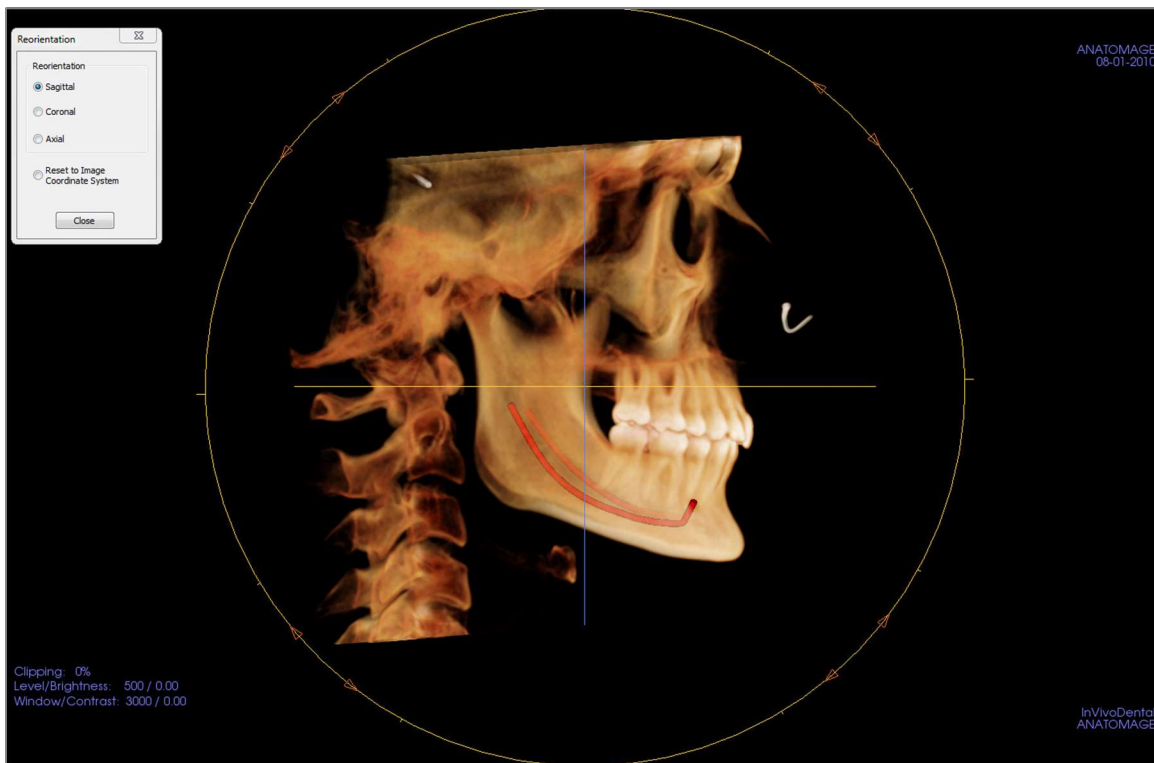
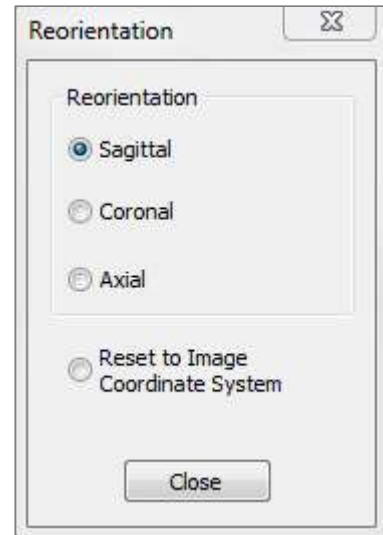



## Volume Render: Render Window

One of the most powerful features of Invivo is the remarkable rendering quality and speed at which the software works. The simplicity of this window is that it only displays the volume, patient information (if desired), and the opacity, brightness and contrast values.

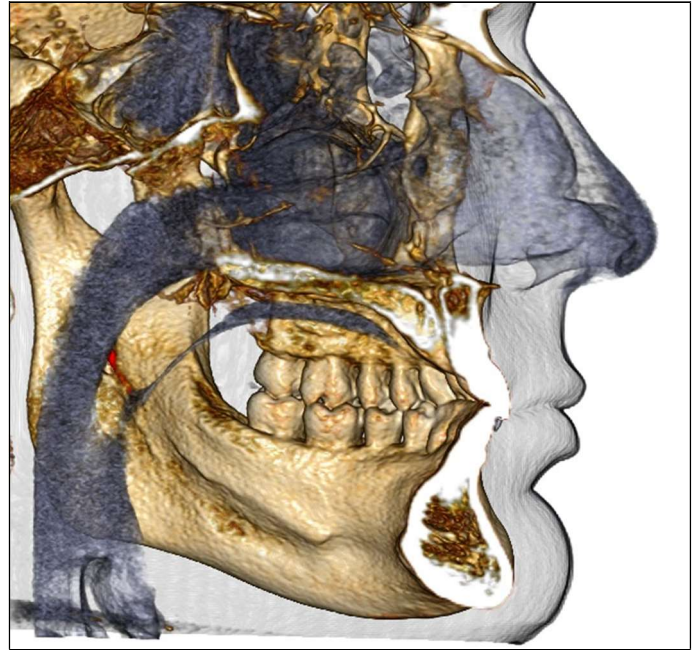
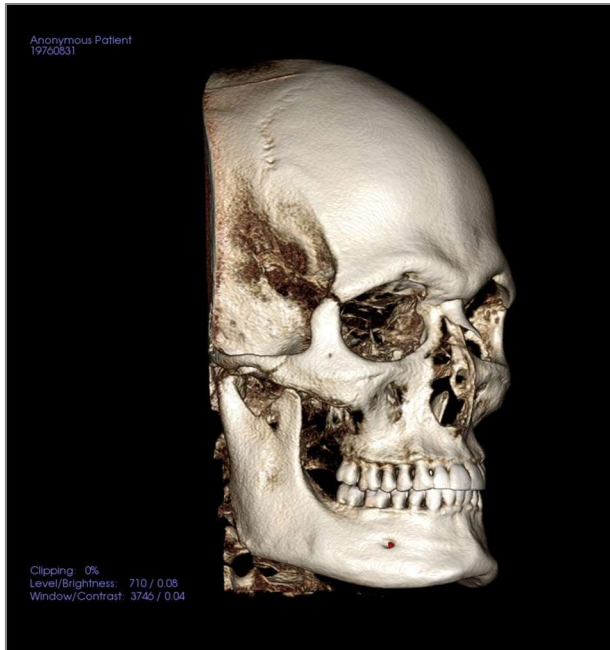

Please refer to [Image Navigation \(pg. 32\)](#) for information about controlling and adjusting these images.



**Warning:** Any measurement that is incorrect can lead to surgical complications if diagnosis, treatment plans and/or actual treatment is based on the incorrect measurements. It is critical for the end user to learn how to perform measurements correctly and employ proper usage of all measurement tools. Measurement accuracy depends on the image data and the hardware scanner that generated the image data. The measurement cannot be more precise than the resolution of the image. Software reports the value based on user-picked points. Due to the nature of medical imaging, the boundary is not always well defined. The apparent boundary depends on the current brightness and contrast setting. The boundary may shift as the user makes adjustments to brightness and contrast. The user must understand the limitation of the measurement value before applying to the patient. If you notice any inconsistencies or software problems with measurements, or have further questions or concerns about using measurement tools correctly, please contact us at (408) 885-1474 or email us at [info@anatomage.com](mailto:info@anatomage.com)

## Volume Render: Volume Measurements

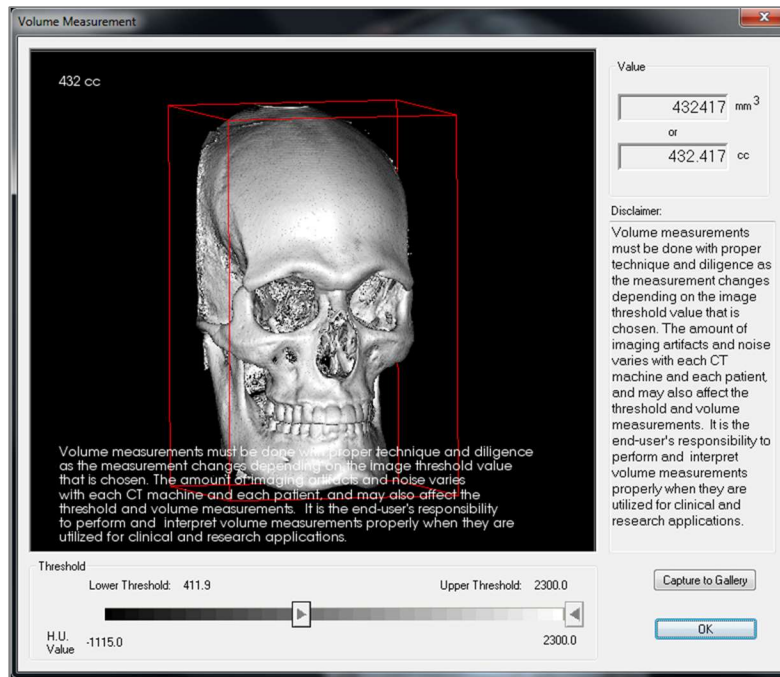

The Volume Measurement interface allows you to estimate displaced volume (cc or cubic millimeters) of a specific anatomical structure. You must first perform sculpting operations to isolate the desired anatomical structure.

Then, press the Volume Measurement  button. The new window will open and the volumetric measurement value will be displayed. Finally, you can adjust the threshold values to obtain desired measurements. The volume measurement function is linked to rendering; the Inverse rendering preset can be used to take volumetric measurements of air.



**Important:** The measurement values may not be true anatomical volumetric measurements. Due to the nature of the imaging, there are imaging artifacts such as white noise, scattering, beam hardening, ring noise or off scale H.U. The software measurement tool cannot distinguish the imaging artifact from the true anatomy. Furthermore, the measurement values depend on threshold values; thus, user must set proper thresholds to get the best estimate of the desired structure. The measurements must not be used as the sole metric for any treatment.



**Warning:** Any measurement that is incorrect can lead to surgical complications if diagnosis, treatment plans and/or actual treatment is based on the incorrect measurements. It is critical for the end user to learn how to perform measurements correctly and employ proper usage of all measurement tools. Measurement accuracy depends on the image data and the hardware scanner that generated the image data. The measurement cannot be more precise than the resolution of the image. Software reports the value based on user-picked points. Due to the nature of medical imaging, the boundary is not always well defined. The apparent boundary depends on the current brightness and contrast setting. The boundary may shift as the user makes adjustments to brightness and contrast. The user must understand the limitation of the measurement value before applying to the patient. If you notice any inconsistencies or software problems with measurements, or have further questions or concerns about using measurement tools correctly, please contact us at (408) 885-1474 or email us at [info@anatomage.com](mailto:info@anatomage.com)

## Volume Render: Airway Measurement



Airway Measurement: Selecting the icon will prompt the dialog box below. Click OK to continue.

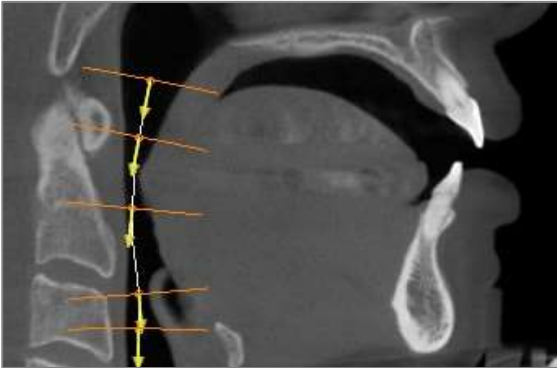
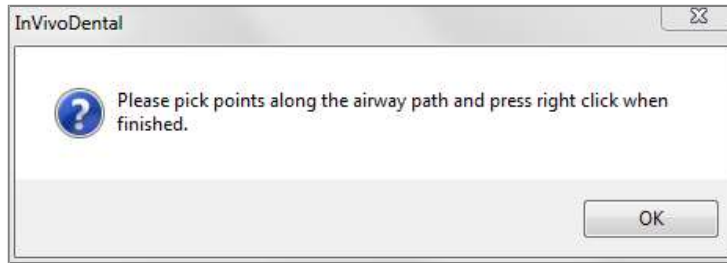

### Tracing the Profile:

- Use the scroll-wheel to locate the mid-sagittal plane.
- Pick points along the airway to define your measurement path with the left-click button.
- Right-click when finished.

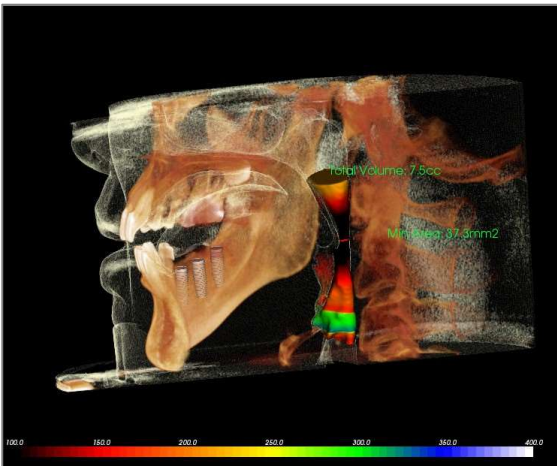

### Viewing the Volume Measurement:

- InVivo will convert your profile tracing into a volume rendering and superimpose it onto the scan data.
- The minimum cross-sectional area and total volume are displayed next to the airway measurement.
- The color range and threshold can be adjusted by selecting the Setup View icon in the Toolbar: 
- The measurement data can be hidden by checking the box for “Hide All Values” in the Control Panel.
- The airway volume and measurement values can be deleted by left-clicking once on the volume, then pressing “delete” on the keyboard.



**Important:** The measurement values may not be true anatomical volumetric measurements. Due to the nature of the imaging, there are imaging artifacts such as white noise, scattering, beam hardening, ring noise or off scale H.U. The software measurement tool cannot distinguish the imaging artifact from the true anatomy. Furthermore, the measurement value depends on threshold values; thus, user must set proper thresholds to get the best estimate of the desired structure. The measurements must not be used as the sole metric for any treatment.



**Warning:** Any measurement that is incorrect can lead to surgical complications if diagnosis, treatment plans and/or actual treatment is based on the incorrect measurements. It is critical for the end user to learn how to perform measurements correctly and employ proper usage of all measurement tools. Measurement accuracy depends on the image data and the hardware scanner that generated the image data. The measurement cannot be more precise than the resolution of the image. Software reports the value based on user-picked points. Due to the nature of medical imaging, the boundary is not always well defined. The apparent boundary depends on the current brightness and contrast setting. The boundary may shift as the user makes adjustments to brightness and contrast. The user must understand the limitation of the measurement value before applying to the patient. If you notice any inconsistencies or software problems with measurements, or have further questions or concerns about using measurement tools correctly, please contact us at (408) 885-1474 or email us at [info@anatomage.com](mailto:info@anatomage.com)

## Volume Render: Movie Capturing and Customized View Sequences

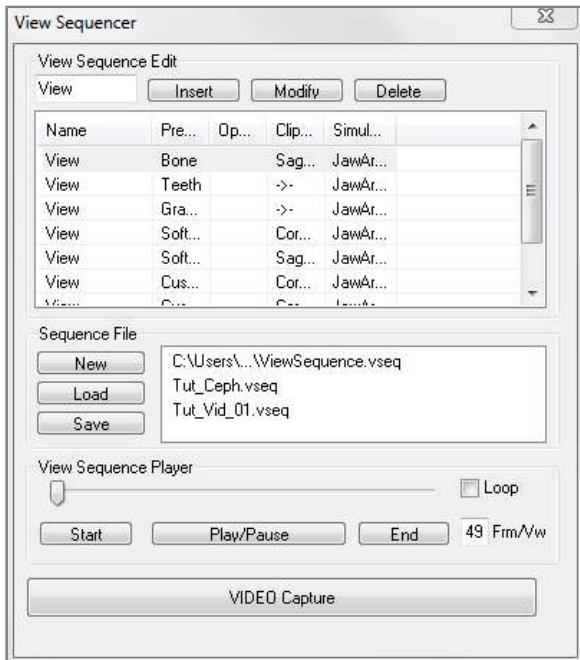

### View Sequence:

- Allows you to create your own sequences by clicking on Insert for each step you want the volume to move in your sequence.
  - *If you want a movie that spins left to right, and then turns up for a submental view, you would add a new frame for each step, and the video capture of it will connect the positions in a seamless movie.*
- You can integrate multiple, different rendering presets so that it switches not only in sequence, but also in colorizations.
- Video sequences can be saved for future use and then loaded using the Load and Save buttons under Sequence File.
- Click on VIDEO Capture to open a dialog to customize and save the movie file.

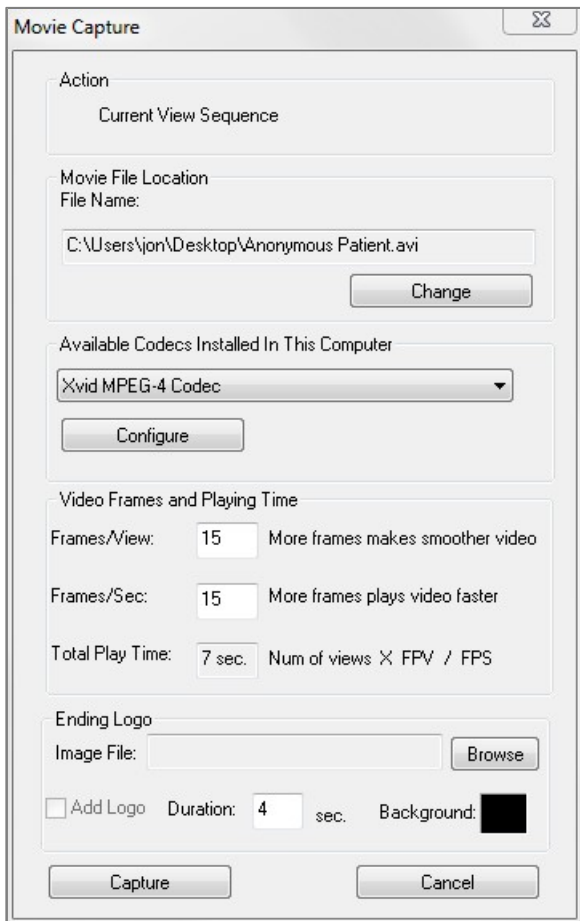

### Movie Capture:

The VIDEO Capture button allows you to customize, capture, and export an AVI (movie) file of the volume rendering sequence.

- Select Change to determine the AVI file name and save location.
- Various codecs that are on your computer can be used to capture the movie at different qualities. If you experience any trouble with the video quality, a different codec may be better.
- Set your frames/view and frames/sec to desired values.
  - *More frames/view will make the video smoother.*
  - *More frames/sec will make the video run faster.*
- Add an ending logo by selecting Browse and choosing an image file to display at the end of your video.
  - *Select "Add Logo" to add the ending image.*
  - *Set your duration and background color.*
- Click Capture once everything is set up to automatically export the video to the specified location with the specified name.

# ArchSection View Features

*ArchSection View Tab is a sectional image exploration view. Instead of conventional X-Y-Z sections, this view allows the user to review the image in dentally meaningful perspectives using multiple cross sections, traversing the lengths of the dental arches.*

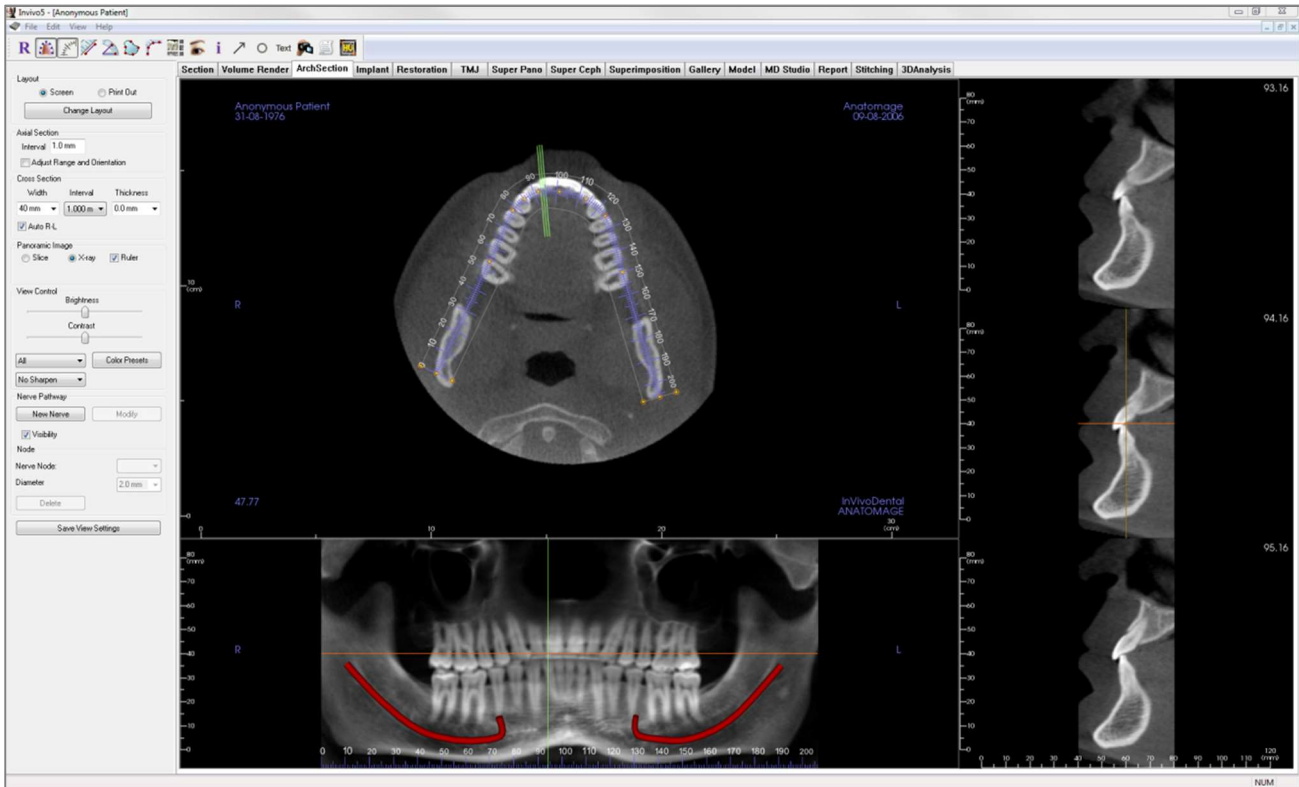

## ArchSection: Toolbar

Shown below are the Toolbar and tools that are loaded with the ArchSection Tab:



**Reset View:** Resets the window to the original view.



**Create Arch Spline (Focal Trough):** After selecting this tool, you can create a new arch spline or edit an existing arch spline. First, left-click on the point you would like to start and continue adding points by left-clicking. After you have marked your final point, right-click or double-click to finalize the arch spline. When modifying an existing arch spline, drag the control points to the desired positions.



**Arch Spline (Focal Trough) Ruler:** Places ruler along the arch spline for easy reference.



**Distance Measurement:** After selecting this tool, click two points to mark the desired distance. A number in millimeters will automatically display.



**Angle Measurement:** Select this option and mark three points on the volume and the angle between them will appear. Clicking on their control points and moving the cursor can modify measurements. Click on the measurement and press the “delete” key to delete it.



**Area Measurement:** After selecting this tool, click multiple points along the boundary of the desired area. Double-click or right-click to end the measurement. A number in millimeters squared will be automatically display. Click on the measurement and press the “delete” key to delete it.



**Polygonal Measurement:** When selected, you may mark an unlimited number of points on the volume and the total between the first point and the last point will appear. Right-click your mouse to indicate that you have marked your last point. Clicking on the point and moving the cursor can modify points. Click on the measurement and press the “delete” key to delete it.



**Layout:** Creates a different layout to your preference. After clicking on the layout icon, a list of various layout options will appear. Click on the layout of your preference to apply it. These options allow for different case workup images.



**Toggle Cursor Visibility:** Conceals or displays cursors.



**Information Display:** Displays or hides case information embedded in the data.



**Arrow Notation:** Allows an arrow to be drawn on the image.



**Circle Notation:** Allows a circle to be drawn on the image.



**Text Notation:** Allows text to be written and edited on the image.



**View Sequence:** Allows for the creation of custom camera sequences and AVI file movie capturing. Refer to the Volume Render View Sequence (pg. 52) section for additional information and description.



**Slice Capture Mode:** Opens the Slice Capture Manager to enable the capture of slices or groups of slices from a series of cross sections. Requires the creation of a slice group in the

Report Tab and an activated Report module.



HU Measurement: Calculates the HU value of an area within a bounding box. The measurements will display alongside the rectangle and can also be repositioned by dragging.



Warning: Any measurement that is incorrect can lead to surgical complications if diagnosis, treatment plans and/or actual treatment is based on the incorrect measurements. It is critical for the end user to learn how to perform measurements correctly and employ proper usage of all measurement tools. Measurement accuracy depends on the image data and the hardware scanner that generated the image data. The measurement cannot be more precise than the resolution of the image. Software reports the value based on user-picked points. Due to the nature of medical imaging, the boundary is not always well defined. The apparent boundary depends on the current brightness and contrast setting. The boundary may shift as the user makes adjustments to brightness and contrast. The user must understand the limitation of the measurement value before applying to the patient. If you notice any inconsistencies or software problems with measurements, or have further questions or concerns about using measurement tools correctly, please contact us at (408) 885-1474 or email us at [info@anatomage.com](mailto:info@anatomage.com)

## ArchSection: Control Panel

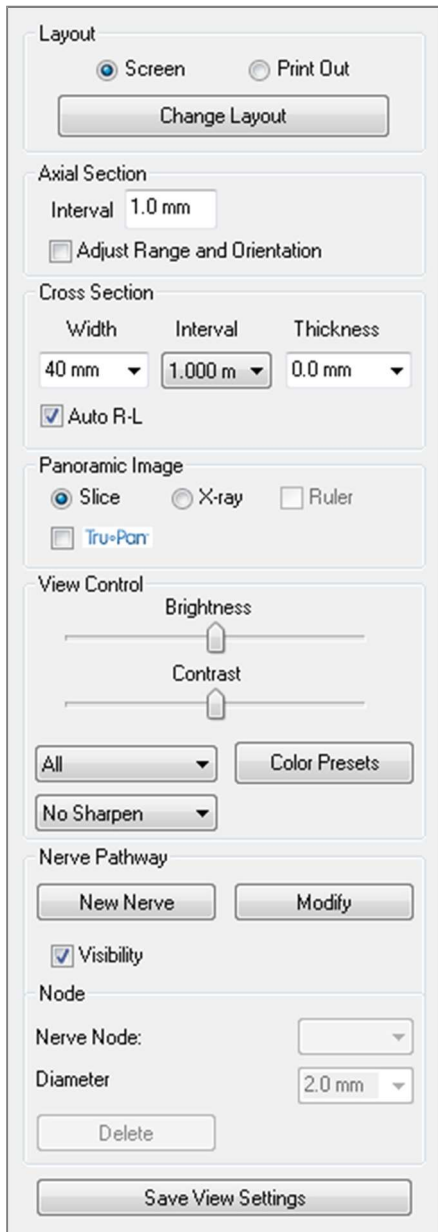

### Layout:

- “Screen” layout is optimized for viewing the image on the computer screen. “Print Out” layout is optimized for printing the image on paper. With Print Out layout, what you see on screen will be printed on the paper in life-size. First, capture to Gallery, then print from Gallery to ensure the image is life size.
- Change Layout allows you to adjust the layout with different amounts of slices and orientations.

### Axial Section:

- Interval: Distance between the subsequent axial sections.
- “Adjust Range and Orientation” will switch to a mode allowing for the adjustment of the upper and lower limit of pano and cross sections. You can also reorient the image in this view.

### Cross Section:

- Width: Cross-section width.
- Interval: Distance between the subsequent cross sections.
- Thickness: Allows for the cumulative thickness of the slices to be viewed in the cross sections.
- Auto R-L: This will allow the cross section to be oriented to a consistent R-L orientation on the screen. If turned off, the cross-section orientation will be consistent to the arch spline.

### Panoramic Image:

- Slice mode will show you a single cross section along the panoramic curve (yellow). This mode is used for tracing the nerve.
- X-ray will show the ray sum (reconstructed x-ray) in the focal trough.

- Tru-Pan™: This option enables the one-click volumetric pano that can be created from scans taken by an i-CAT© Cone Beam 3D system. (This setting is only displayed in the Control Panel when a Tru-Pan™ case is currently loaded.)

### View Control:

- Brightness and Contrast allow you to adjust the image.
- The All drop-down allows you to adjust brightness/contrast in different areas independently.
- Different Color Presets can be used to view the images in color.
- Sharpening Filter applies the selected sharpening filter from the drop-down menu to the 2D slice renderers.



### Nerve Pathway:

- New Nerve: Starts a new nerve tracing.
- Modify: Allows editing of the selected nerve tracing.
- Visibility: Controls the visibility of the nerve in the section and X-ray renderers.
- Nerve Node: Select a specific node for modification.
- Diameter: Selects the diameter of the nerve that has been traced or a specifically selected node.
- Delete: Deletes the last placed node during the tracing or the entire nerve if Modify is active.

### Save View Settings

Saves the current 2D View settings to be reloaded upon opening any case. See the Display Preferences section in Preferences (pg. 19) for more information on which settings are saved for this specific tab.

## ArchSection: Creating A Nerve Pathway

*Creating a Nerve Pathway (e.g. Inferior Alveolar by following the mandibular canal to its exit).*

- Click New Nerve.
- Left-click the mouse where you want the nerve to start.
- Move the mouse to the next point along the nerve path and left-click again.
- Click Delete to remove the last-placed node if it is mispositioned.
- Repeat this procedure for the entire length of the nerve.
- 2.0mm is the default diameter of the nerve pathway, but you may adjust it for your preference.
- Press Done to finish.

*Editing a Nerve Pathway*

- Click on a nerve tracing to select it. This highlights it in a brighter red color.
- Set the Nerve Node drop-down menu to “All” or a specific node.
- If “All” is selected, the entire nerve tracing’s diameter can be adjusted.
- If a single node is selected, it will be highlighted in the scan, and its diameter and position may be adjusted independently. The nerve node diameter is adjusted in the Diameter drop-down menu. The highlighted node can be moved by clicking and dragging it across the scan.

*Deleting a Nerve Pathway*

- The Delete button can be used if a point was plotted in the wrong spot; it will delete the last point added.
- Once a nerve has been completed and Done has been clicked, the nerve can be deleted by clicking on it and pressing the “delete” key on the keyboard or the Delete button.
- Visibility will turn the nerve on or off from view.



**Warning:** Any nerve that is traced in a way that does not conform to the actual pathway of the nerve can lead to surgical complications if diagnosis, treatment plans and/or actual treatment is based off of the incorrect tracing. It is critical for the end user to learn how to properly perform nerve tracings correctly. If you notice any inconsistencies or software problems with nerve tracing or have further questions or concerns about nerve tracing, please contact Anatomage support at (408) 885-1474 or email us at [info@anatomage.com](mailto:info@anatomage.com)

## ArchSection: Rendering Window

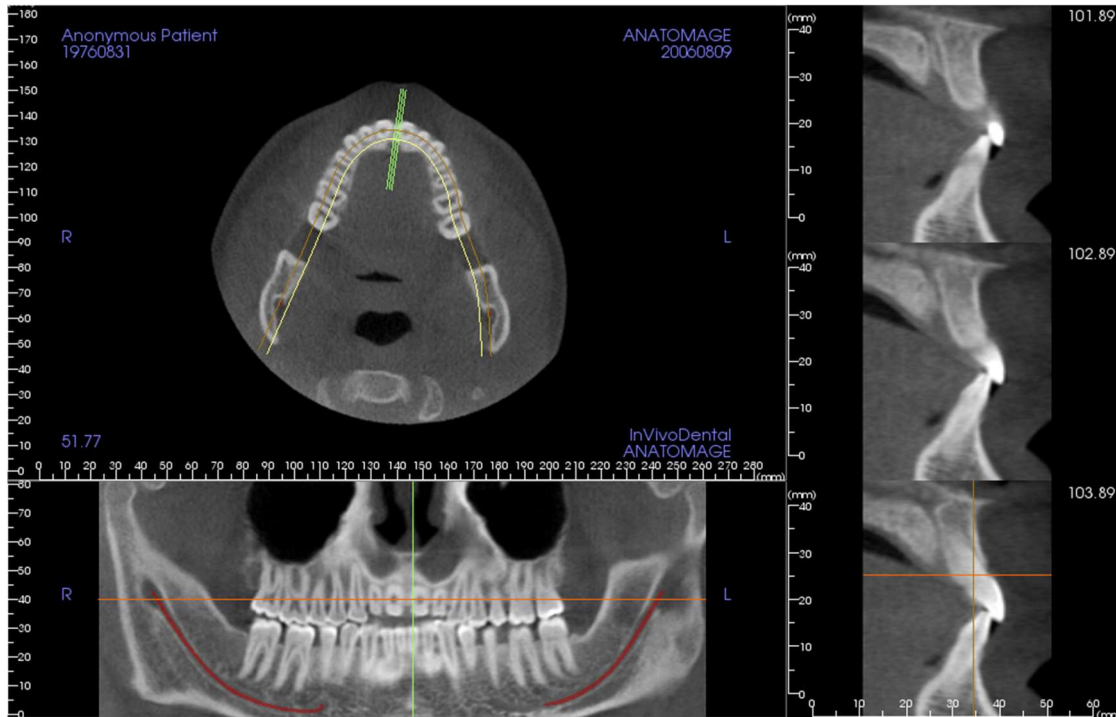

Arch Cursor: Notice the green, orange, and brown coordinate indicators. These ArchSection coordinate indicators show where you are spatially located within the ArchSection modeling window.

- Cross Section Indicator: The green lines give the location of the cross sections along the arch spline.
- Axial Slice Indicator: The orange line shows the axial coordinate position within the section.
- Arch Spline: The brown spline in the center of the arch spline represents the current position where the arch section has moved.
- Cross Section: Mouse scrolling within any one of the three sagittal frames advances the slices to the patient's right or left and causes the green coordinate indicator to move anteriorly or posteriorly in the axial and pano sections simultaneously.
- Axial Section: Mouse scrolling within the axial section advances the sections superiorly or inferiorly and causes the red coordinate indicator to move superiorly or inferiorly in the cross or pano sections simultaneously.
- Pano Section: Mouse scrolling within the coronal frame advances the slices buccally or lingually and causes the brown coordinate indicator to move buccally or lingually in the axial and cross sections simultaneously.

# Implant View Features

*The Implant View Tab allows you to access the full-featured implant planning module.*

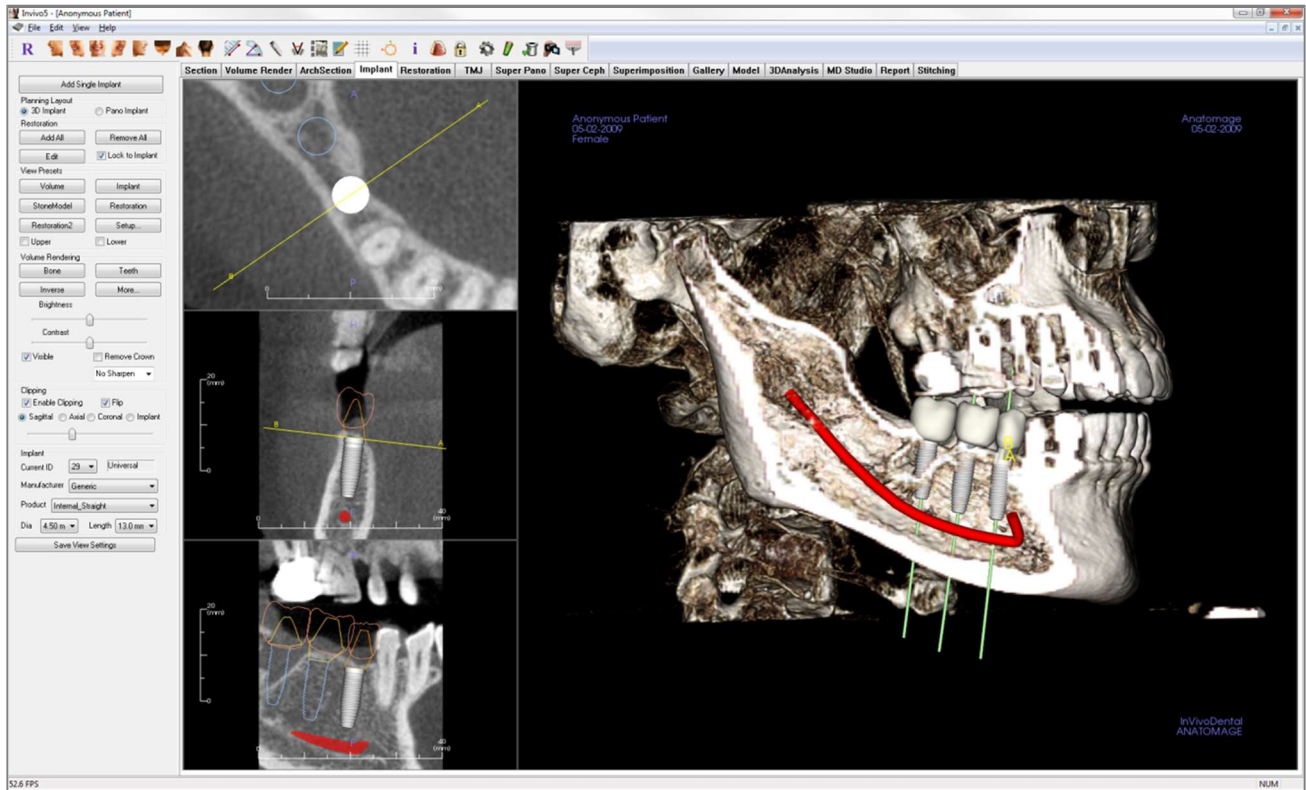

## Implant: Toolbar

Shown below are the Toolbar and tools that are loaded with the Implant View Tab:



Reset Views: Resets the rendering window to the original view.



Left View: Automatically orients the volume so the patient is facing left sagittal.



Left  $\frac{3}{4}$  View: Automatically orients the volume so the patient is facing 45° left sagittal.



Front View: Automatically orients the volume so the patient is facing the front.



Right  $\frac{3}{4}$  View: Automatically orients the volume so the patient is facing 45° right sagittal.



Right View: Automatically orients the volume so the patient is facing right sagittal.



Top View: Automatically orients the volume so you are oriented above the patient.



Bottom View: Automatically orients the volume so you are oriented below the patient.



Back View: Automatically orients the volume to the posterior view.



Distance Measurement: Select this option and mark two points on the volume and distance will appear. Clicking on the point and moving the cursor can modify points. Click on the measurement and press the “delete” key to delete it. Control Panel features in Volume Render Tab allow the values to be projected to 2D, hidden, or exported to a report.



Angle Measurement: Select this option and mark three points on the volume and the angle between them will appear. Clicking on their control points and moving the cursor can modify measurements. Click on the measurement and press the “delete” key to delete it. Control Panel features in Volume Render Tab allow the values to be projected to 2D, hidden, or exported to a report.



Insert Implant: To place an implant, first click the Add Implant icon, select the Tooth ID for the implant, then left-click the mouse on the spot that you want the implant to be placed. Note: specific manufacturers measure the implant from different points, so a measurement in the software might not be the same as the actual measurement of the specific implant design.



Show Implant Angle Dialog: Opens a window displaying all the angles between placed implants.



Change Layout: Toggles the rendering window layout.



Create Summary: Creates an Implant summary of images that is added to the Gallery. Images contain ID (FDI), implant product, diameter, and length information in the lower right hand corner of the screenshot. The user will also be given an option to print a reference chart which lists the implants placed (including implant site, manufacturer, product name, diameter and radius) for each arch.



**Toggle Grid:** Toggles between two different grid layouts for use in the upper two section frames allowing quick assessment of measurements and spatial location.



**Toggle Move Widget:** Toggles the implant orientation widget on and off.



**Information Display:** Displays or hides case information embedded in the data.



**Change Model Visibility:** Allows various models to be turned on or off from view.



**Treatment Lock:** Locks the implants in place so that they are not accidentally moved when viewing the 3D images.



**Preferences:** Allows you to adjust the different rendering, color, and visibility preferences.



**Density Profile Control:** Adjust the settings for the displayed density profile around planned implants.



**Check Sleeves:** The program will search for collisions between the sleeves, instruments, and stone models.



**Generate View Sequence:** Opens a dialog that provides view sequence presets to create a video.



**Visualize Bone Graft Volume:** Simulates a bone graft near the apex of an implant and displays its volume.



**Warning:** Any measurement that is incorrect can lead to surgical complications if diagnosis, treatment plans and/or actual treatment is based on the incorrect measurements. It is critical for the end user to learn how to perform measurements correctly and employ proper usage of all measurement tools. Measurement accuracy depends on the image data and the hardware scanner that generated the image data. The measurement cannot be more precise than the resolution of the image. Software reports the value based on user-picked points. Due to the nature of medical imaging, the boundary is not always well defined. The apparent boundary depends on the current brightness and contrast setting. The boundary may shift as the user makes adjustments to brightness and contrast. The user must understand the limitation of the measurement value before applying to the patient. If you notice any inconsistencies or software problems with measurements, or have further questions or concerns about using measurement tools correctly, please contact us at (408) 885-1474 or email us at [info@anatomage.com](mailto:info@anatomage.com)



**Warning:** Any implants and restorations that are incorrectly visualized in Restoration Design Studio may lead to surgical complications or treatment delays. If you notice any inconsistencies or software problems with implant or restoration planning or have further questions or concerns, please contact Anatomage support at (408) 885-1474 or email us at [info@anatomage.com](mailto:info@anatomage.com)



**Warning:** Any implant planning that is performed incorrectly in any aspect including but not limited to implant location, orientation, angle, diameter, length, and/or manufacture can lead to surgical complications if diagnosis, treatment plans and/or actual treatment is based off of the implant planning error(s) in question. It is critical for the end user to learn how to use the implant treatment planning tools correctly. If you notice any inconsistencies or software problems with implant planning or have further questions or concerns about correct utilization of implant planning, please contact Anatomage support at (408) 885-1474 or email us at [info@anatomage.com](mailto:info@anatomage.com)

## Implant: Control Panel

### Add Single Implant:

- Click to add single implant to the 3D volume.
- Adjust the implant orientation and placement using the move widget that appears on the selected implant.

### Planning Layout:

- 3D Implant: Place and adjust individual implants on 3D volume.
- Pano Implant: Add multiple implants using the Pano view, select “3D Implant” to exit Pano view and re-adjust individual implants.

### Restoration:

- Add All: Adds default restorations to all the implants.
- Remove All: Removes all restorations.
- Edit: Transfers the current progress to the Restoration Tab for advanced crown placement and design. See the Implant: Advanced Restoration Design section (pg. 71) for more information.
- Lock to Implant: When selected, the implant and restoration will move as a single unit.

### View Presets:

- Setup: Opens a dialog where the view presets can be configured.
- Presets: Preset toggles that display the selected features as configured in the Setup.
- Upper/Lower: Toggles the visibility of the stone models if present.

### Volume Rendering:

- Rendering Types: Different settings allow for better visualization of certain anatomic structures, soft tissue profiles, hard tissue, etc. This is achieved by displaying specific densities with specific colors.
- Brightness & Contrast: Can be adjusted for each of the presets to enhance your image.

- Visible: Allows the 3D Volume Rendering to be turned on or off from view.
- Remove Crown: Only applicable with surgical guide-related modeling service options.
- Tru-Pan™: This option enables the one-click volumetric pan that can be created from scans taken by an i-CAT© Cone Beam 3D system. (This setting is only displayed in the Control Panel when a Tru-Pan™ case is currently loaded.)
- Sharpening Filter: Applies the selected sharpening filter from the drop-down menu to the 2D slice renderers.

### Clipping:

Click the “Enable Clipping” box to slice the image along the predefined anatomical planes (sagittal, axial, coronal, and arch). Scrolling the mouse wheel or moving the slider will move the clipping plane. To switch a view to the opposite side, click “Flip.”

### Implant:

The implant section can be configured to only show specific implants as defined by the user. For more information, look at the Preferred Implant settings further in this section.

- **ID:** Use the drop-down menu to select an implant to manipulate. The active implant will appear lighter in color than the others.
- **Manufacturer, Product Name, Diameter, and Length:** The default is generic, but you may select a specific implant manufacturer, diameter, and length.

### Save View Settings

Saves the current 2D view settings to be reloaded upon opening any case. See the Display Preferences section in Preferences (pg. 19) for more information on which settings are saved for this specific tab.



## Implant: Rendering Window

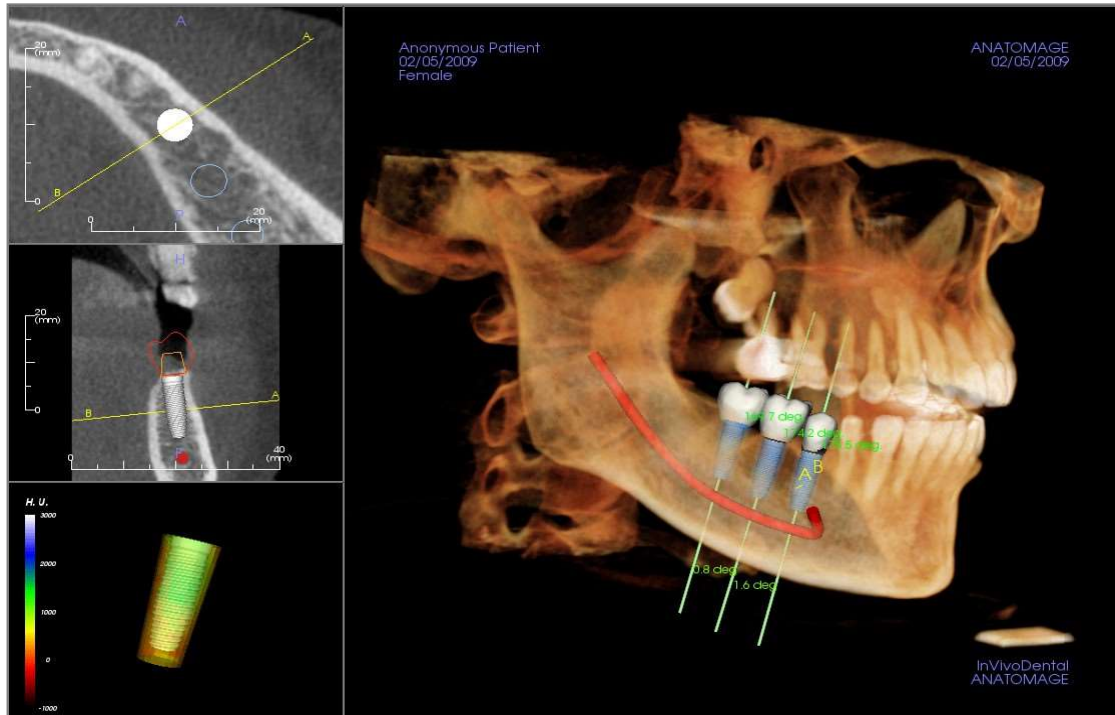

Used for more precise control and final detailed touches to implant treatment planning. Using the navigation discussed below, you can visualize all aspects of the implant in the 3D volume. For further information on implant position and sizing using the implant widgets, please refer to the next section of the manual. **Once an implant is added, it will also appear in the Volume Render View.**

**Axial Section:** Top left window. This section is the view from the top of the implant. The yellow line passing through the axis creates the view seen in the sagittal view. Scrolling the mouse wheel after clicking inside the axial window, or clicking and dragging the line will change the cross section seen in the sagittal view as the line rotates about the axis of the implant. Asymmetrical (STL) implants can be rotated about the long axis in this view (see the next section).

**Sagittal Section:** Middle left window. This section is the view from the side of the implant. The A-B line passing through the implant creates the cross-section view that appears in the axial view and is set by default to be positioned at the level of the implant emergence point. Scrolling the mouse wheel after clicking inside the sagittal window, or clicking and dragging the line will change the cross section seen in the axial view. The implant widget in this view allows for quick resizing of implant length and diameter (see the next section).

**Density Profile:** Lower left window. Displays a real-time visualization of the volume density immediately surrounding the implant.

**Volume Rendering:** Right window. This frame allows user to change the implant position and orientation with the orientation widget within the 3D volume rendering.



**Warning:** Any implant planning that is performed incorrectly in any aspect including but not limited to implant location, orientation, angle, diameter, length, and/or manufacture can lead to surgical complications if diagnosis, treatment plans and/or actual treatment is based off of the implant planning error(s) in question. It is critical for the end user to learn how to use the implant treatment planning tools correctly. If you notice any inconsistencies or software problems with implant planning or have further questions or concerns about correct utilization of implant planning, please contact Anatomage support at (408) 885-1474 or email us at [info@anatomage.com](mailto:info@anatomage.com)

## Implant: View Preset Setup

Visibility presets allow for easy switching between set views during implant planning. To configure these settings, click on Setup. These presets may also be modified in the Restoration Tab.

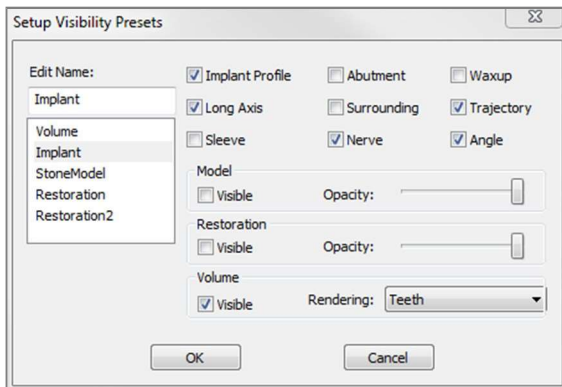

- **Edit Name:** Click on any preset to select it. Type the new name into the field.
- **Visibility checkboxes** hide or show features in the rendering window.
- **Implant Profile:** Controls the visibility of the solid implant cross section in the 2D renderers. When activated, the currently selected implant will have a red profile and the unselected implants will have blue profiles. When not activated, the selected implant will show an opaque cross section of the implant and the unselected implants will show as blue profiles.

- **Abutment:** Controls the visibility of the abutment 3D model in the volume renderer or the colored profile in the 2D slice renderers.
- **Waxup:** Controls the visibility of the profiles in the 2D renderers and 3D models on the volume. Option is only available after they have been added by an Anatomage technician as part of a surgical guide case workup.
- **Long Axis:** Displays a colored rod running through the long axis of the implant in the volume render.
- **Surrounding:** Displays the surrounding volume around an implant. The collision zone is determined by the allowance defined in the preferences.
- **Trajectory:** Displays the simulated trajectory of the implant during surgical placement.
- **Sleeve:** Controls the visibility of the profiles in the 2D renderers and 3D models on the volume. Option is only available if the mandibular and maxillary models are available as well as after the Check Sleeve action has been performed.
- **Nerve:** Displays a 3D nerve in the volume render or a cross section of the nerve in the 2D section renderers.
- **Angle:** Controls the visibility of the angle between the long axes of adjacent implants as well as the angles of the abutment for each implant.
- **Model:** Controls the visibility of the stone models. Varying degrees of transparency can be obtained with the Opacity slider.
- **Restoration:** Controls the visibility of the 3D waxup models in the volume renderer and the colored profile in the 2D section renderer. The colored profile of the selected restoration or restoration associated with the selected implant will be red while the unselected restorations will be pink. Varying degrees of transparency can be obtained with the Opacity slider.
- **Volume:** Controls the visibility of the volume render as well as the rendering type.

## Implant: Model Visibility

The  Change Model Visibility function will open the Model Object Settings dialog.

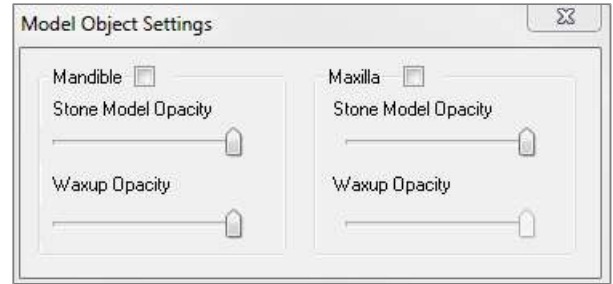

- The “Mandible” and “Maxilla” checkboxes control all of the model visibility options (except Profile Only and Density) and allow the user to turn off the set of models for each jaw independently. *Note: The visibility checkboxes in Model Object Settings will not always match the checked/unchecked status of the visibility checkboxes in the Control Panel.*
- The Stone Model and Waxups Opacity can be adjusted for both jaws.

## Implant: 3D Implant Widget

The  3D implant widget is designed to optimize visibility in the renderer and provide a high level of versatility in implant positioning. The linear, colored arrows can be dragged to reposition the implant transversely. These arrows only appear when the camera perspective is close to orthogonal. The implant may also be moved along these directions using the keyboard arrow keys.

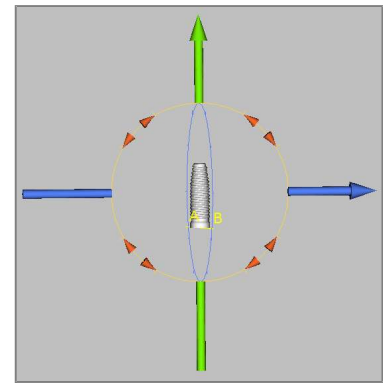

- The yellow arrow (not shown) is parallel to the A-B line.
- The blue arrow is orthogonal to the green and yellow arrows.
- The green arrow runs through the long axis of the implant.
- The rotation circle appears on the same plane as the two arrows that are close to orthogonal to each other and to the camera perspective and features eight handles for rotation.

## Implant: 2D Implant Widget

The 2D implant widget is designed to optimize visibility in the slice renderer and provide a high level of versatility in implant positioning and sizing. The implant may also be moved along its long axis or orthogonally with the keyboard arrow keys.

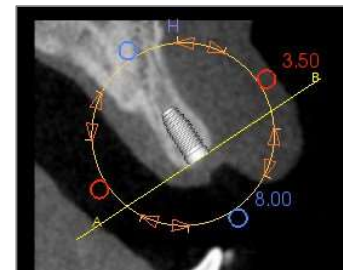

- The rotation circle has eight arrows for implant rotation along the same plane as the currently displayed slice.
- The two red handles can be selected and dragged toward/away from the implant to reduce/expand the diameter of the implant sequentially through any available options for that implant model.
- The two blue handles can be selected and dragged toward/away from the implant to reduce/expand the length of the implant sequentially through any available options for that implant model.
- The implant model itself can be selected and dragged in any direction along the same plane as the currently displayed slice.
- A rotation circle appears when the product cross section is selected that allows for implant rotation about the long axis of asymmetrical (STL) implants in the top left section renderer. Please contact Anatomage for an updated list of asymmetrical (STL) implants.

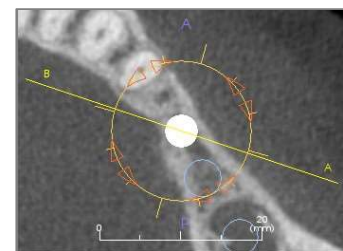

## Implant: 3D Implant Planning



- In the Control Panel, click the Add Single Implant button.
- The implant ID dialog will show up (image below).
- Select the implant ID to be inserted. Press OK, and a new implant will appear on the mouse pointer.
- Drag and drop the implant in 3D view onto the surgical site. (It helps to have the volume rotated so that the surgical site is centered.)
- In axial view, align the yellow line such that the lower cross-section view becomes the view along mesiodistal direction.
- In cross-section view, re-orient and position the implant so that its angle is as desired.
- In axial view, align the yellow line such that the cross-section view becomes the view along the buccolingual direction.
- In cross-section view, re-orient and position the implant so that its angle is as desired.
- Review the final implant position in 3D view.
  - To delete an implant, select the desired implant in the 3D view and press the “delete” key on the keyboard. The implant will be removed.

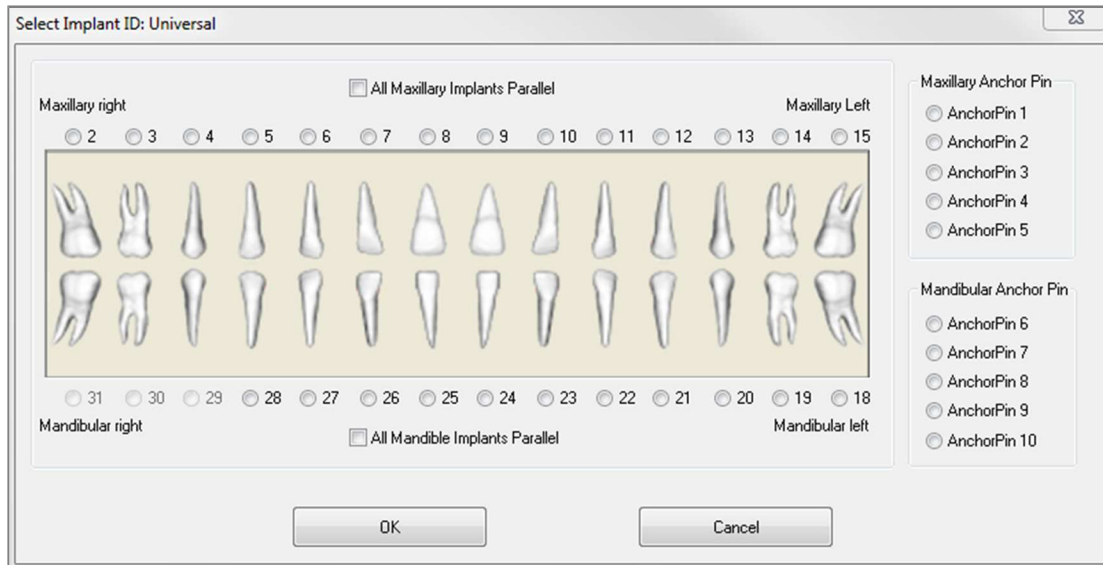

A similar procedure can be done to add anchor pins to your 3D volume. Select which anchor pin you would like to add and follow similar steps for adjusting its position.

## Implant: Pano Implant Planning

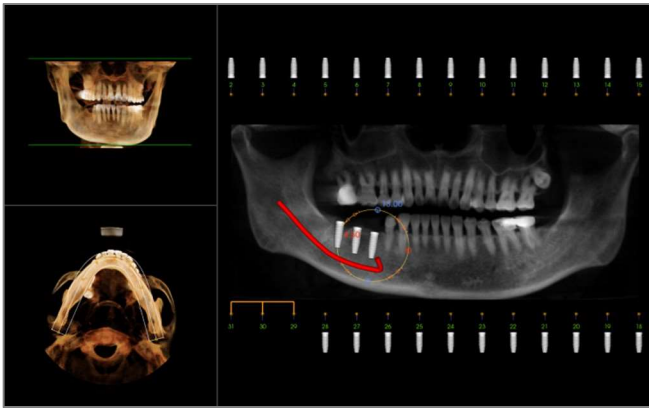

- Select Planning Layout: Pano Implant under the Control Panel in the Implant Tab.
  - Rendering window updates to pano view (left).
  - Adjust the ArchSection focal trough such that the middle profile passes through the dentition.
  - Drag implants to their desired locations and adjust their angles.
  - Click to select implants and manipulate them in the cross sections.
- Click the nodes above the implant identification numbers and connect them with other implants to create parallel implant groups. Remove the implants from these groups by clicking on the nodes again.
  - Repeat for all desired implants.
  - Select Planning Layout: 3D Implant to exit Pano-Mode and further adjust individual implants.

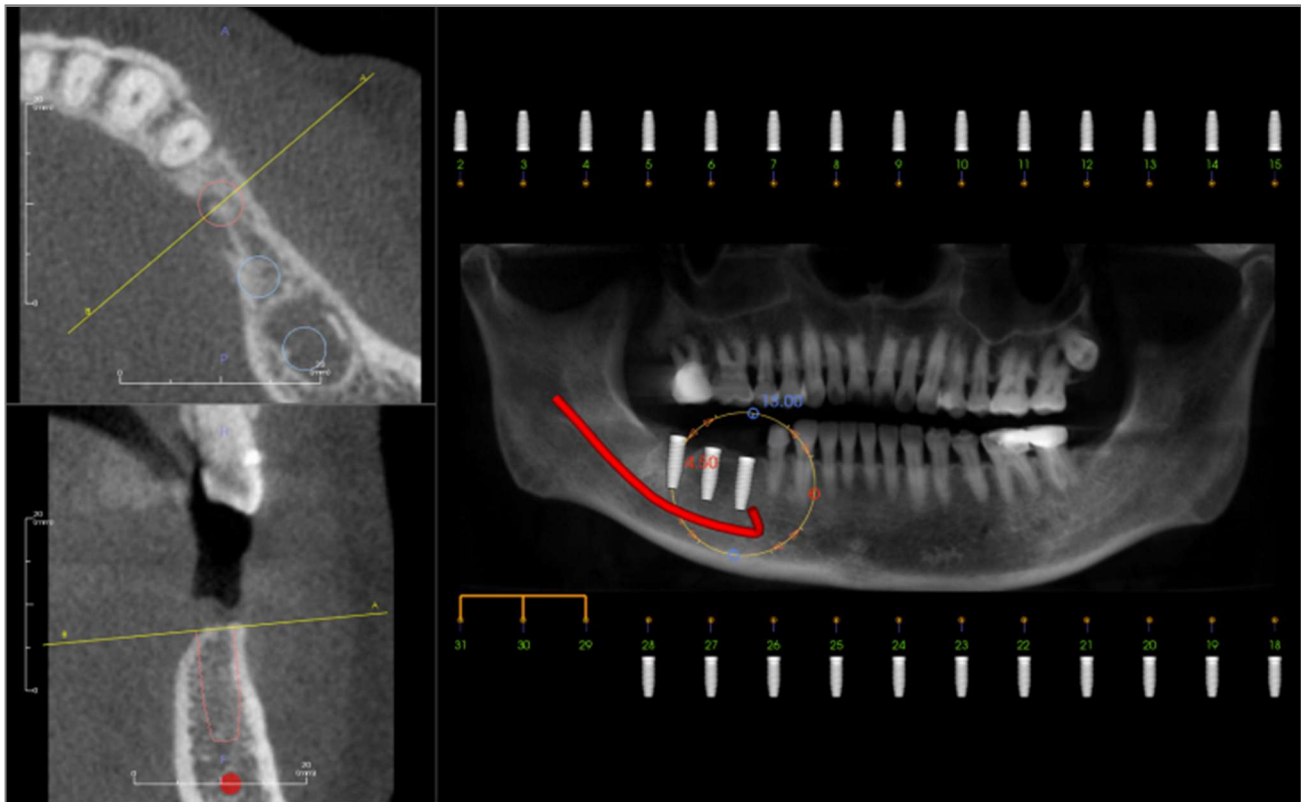

## Implant: Bone Graft Simulation

- Select the implant that requires a bone graft and click the Visualize bone graft volume tool .
- The graft simulation tool will appear as an arc that moves along the central axis of the implant in the cross section.
- Click to place the graft in the desired position.
- The resulting graft will appear in the 2D sections in blue and in the volume rendering in off-white.
- The volume of the graft will be displayed in the volume rendering.
- The graft can be deleted by clicking on it to select it and pressing the “delete” key on the keyboard.

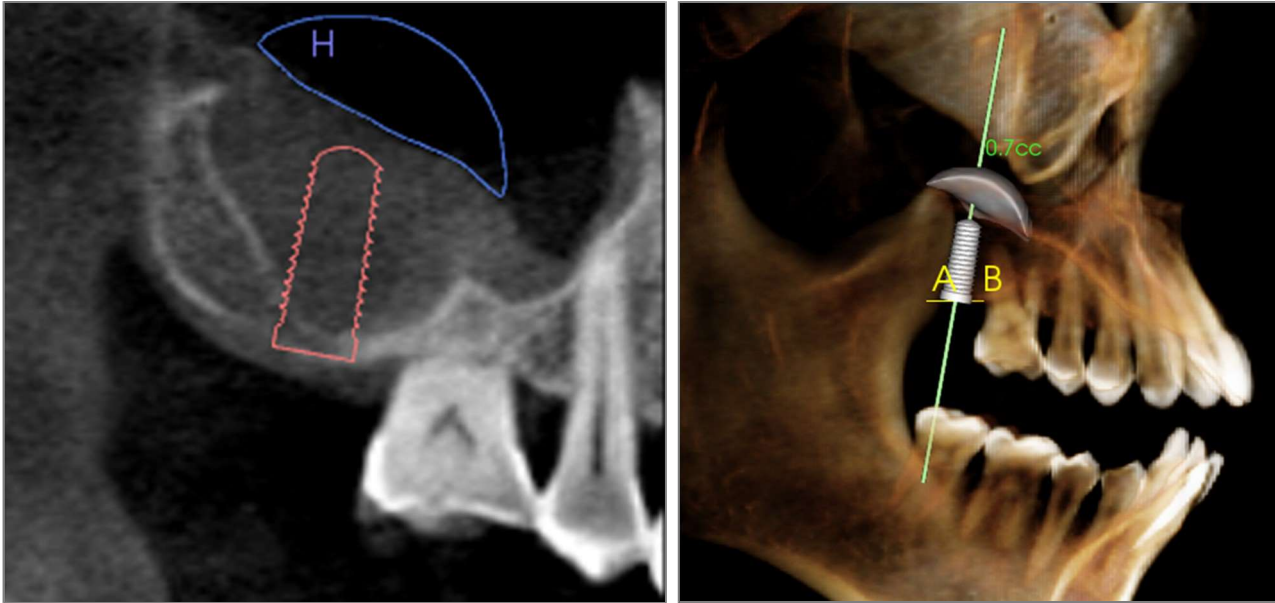

**Important:** The measurement values may not be true anatomical volumetric measurements. Due to the nature of the imaging, there are imaging artifacts such as white noise, scattering, beam hardening, ring noise or off scale H.U. The software measurement tool cannot distinguish the imaging artifact from the true anatomy. Furthermore, the measurement value depends on threshold values; thus, user must set proper thresholds to get the best estimate of the desired structure. The measurements must not be used as the sole metric for any treatment.



**Warning:** Any measurement that is incorrect can lead to surgical complications if diagnosis, treatment plans and/or actual treatment is based on the incorrect measurements. It is critical for the end user to learn how to perform measurements correctly and employ proper usage of all measurement tools. Measurement accuracy depends on the image data and the hardware scanner that generated the image data. The measurement cannot be more precise than the resolution of the image. Software reports the value based on user-picked points. Due to the nature of medical imaging, the boundary is not always well defined. The apparent boundary depends on the current brightness and contrast setting. The boundary may shift as the user makes adjustments to brightness and contrast. The user must understand the limitation of the measurement value before applying to the patient. If you notice any inconsistencies or software problems with measurements, or have further questions or concerns about using measurement tools correctly, please contact us at (408) 885-1474 or email us at [info@anatomage.com](mailto:info@anatomage.com)

## Implant: Advanced Restoration Design

Invivo features advanced restoration design functions located in the Restoration Tab (see the Restoration section for more information on this tab, pg. 78). Compatibility between files saved in different Invivo versions will cause certain behaviors that accommodate this new functionality, as described below:

### Scenario:

1. Opening an Invivo file containing a restoration workup from any version prior to 5.3:
2. Opening an Invivo file saved in Invivo 5.3 or a later version with an implant and restoration workup in earlier versions of Invivo:
3. Opening an Invivo file saved with implants from any earlier version, but no restorations:

### Consequence:

1. The Implant tab will display these restorations as they were last saved. Upon going to the Restoration Tab, the program will attempt to convert the original restorations into crowns from the new library. If the user chooses not to convert the restorations (No), they will be brought back to the Implant Tab.



2. The earlier versions of Invivo will not be able to display the restoration crowns in the Implant or Model Tabs.
3. The implant workup will be loaded, and the user will be able to add restorations from the Restoration teeth library.

## Implant: Adding Restorations

Restorations can be added directly to all the implants using the Add All button. A default restoration will be placed on each implant that does not yet have a restoration. The Remove All button will remove all the placed restorations. The Edit button will present the option to do further editing in the Restoration Tab. Locking the restorations to implant will automatically move the restorations when the implants are moved. Restorations may also be added, edited, or removed in the Restoration Tab (see Restoration section for more information, pg. 78). The Restoration Tab view is synchronized with the Implant Tab view for ease of editing between the two tabs.



## Implant: Check Sleeves

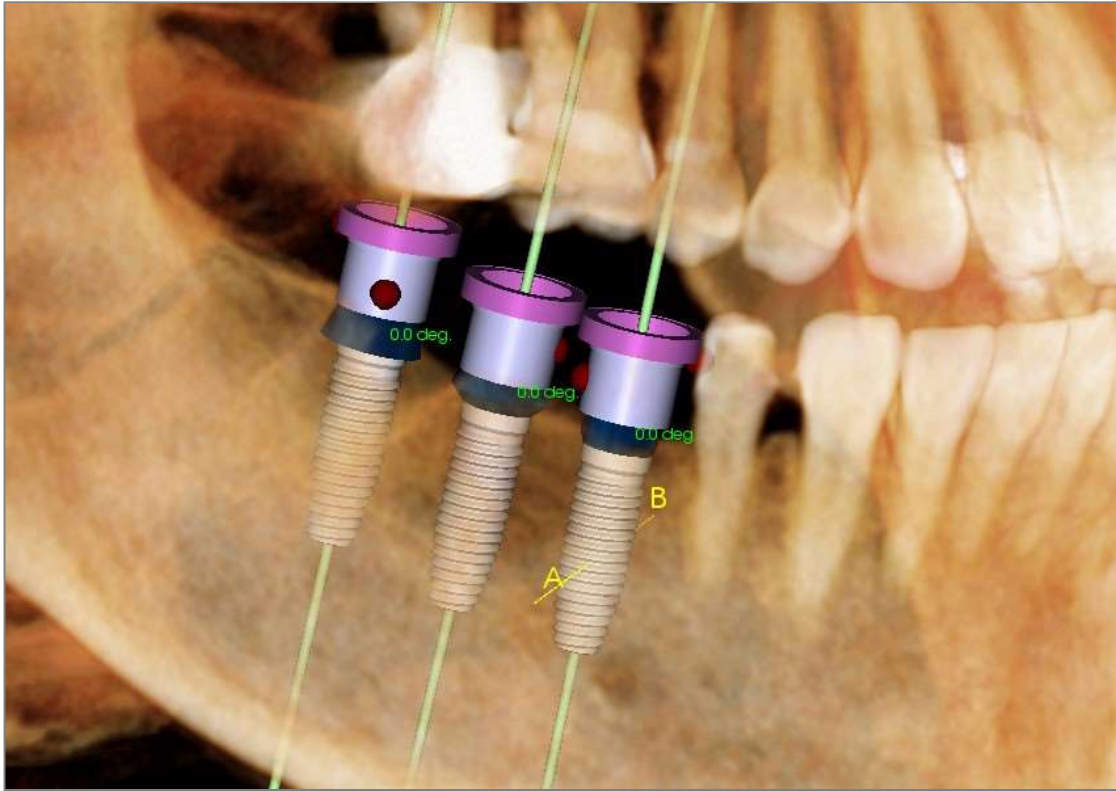

The  Check Sleeves function can be performed to determine the position of where sleeves would be if a surgical guide was produced for implant placement. This function will simulate possible collisions that may occur between:

- Sleeves and other sleeves
- Sleeves and the instrument
- Sleeves and the stone model
- Instrument and the stone model

Interference: Demonstrated visually by a dark red-colored sphere. **These interference indicators are not updated in real-time and will only be rechecked after each instance that Check Sleeves is performed.**

Check Sleeve Interference: The user can change certain preferences to better simulate the actual procedure that will be performed, such as sleeve system, instrument, sleeve size, and drill. Solution options are to change implant planning, change sleeve preferences, or to allow a technician to try to resolve the interference.

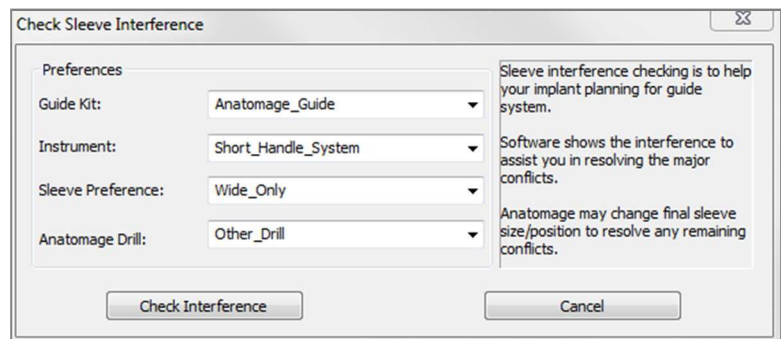

The option to check sleeves will automatically appear when attempting to save Anatamage Surgical Guide planning files.



## Implant: View Sequencer

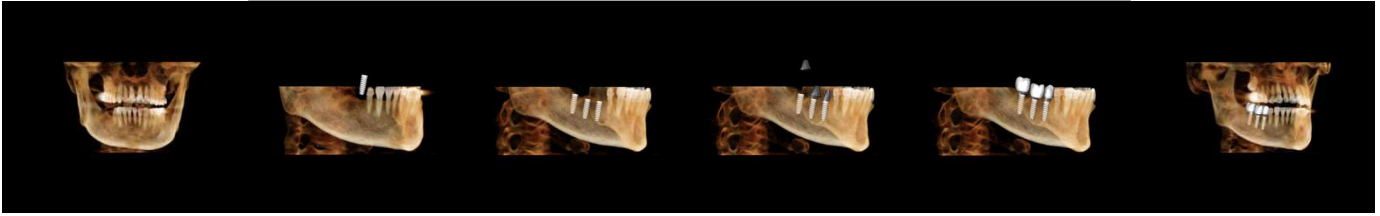

- The  implant view sequencer is a movie-creating tool that contains both an axial and buccal (shown above) preset sequence of view positions and rotations.
- The sequence is adapted to be used with any case and immediately played as a preview.
- A movie file (.avi) that resembles the preview can be captured.



### View Sequencer

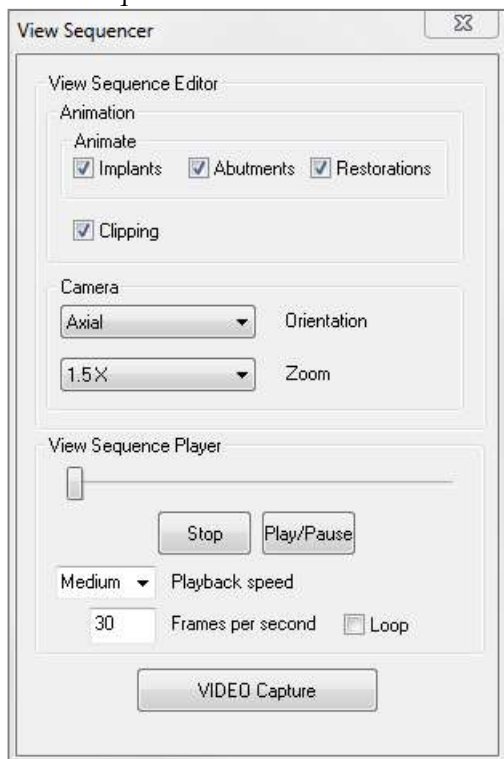

#### Animation

- **Animate:** Set the sequence to animate the placement of implants, abutments, and restorations.
- **Clipping:** Set the sequence to include the preset clipping actions.

#### Camera

- **Orientation:** Set the orientation to be axial or buccal.
- **Zoom:** Set the zoom level of the rendering window (None, 1.5X, 2.0X).

#### View Sequence Player

- **Slider:** Shows the current progress through the video while allowing navigation through the preview by clicking and dragging.
- **Stop:** Stop the preview.
- **Play/Pause:** Starts the video/pauses the video/resumes the video.
- **Playback speed:** Speed of playback (slow, medium, fast).
- **Frames per second:** Sets the smoothness of the preview playback.
- **Loop:** Sets the preview to loop at the end of playing the sequence.

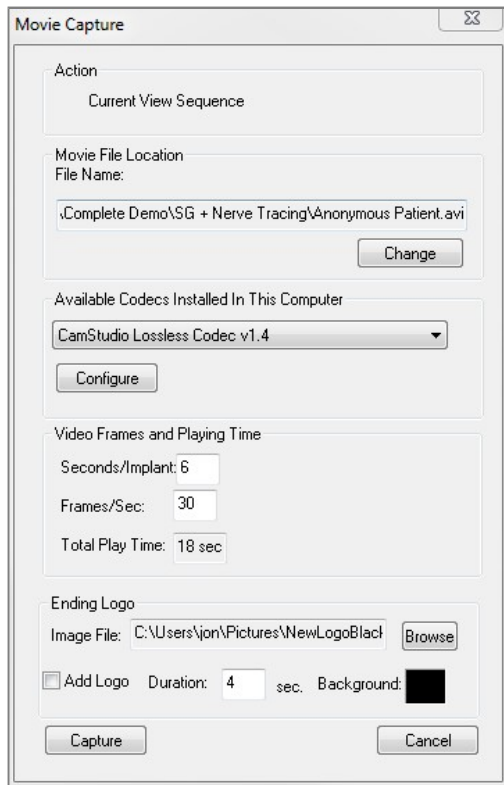

### Action

The current view sequence will be captured into a movie file.

### Movie File Location

Choose the location to save the file by clicking Change.

### Available Codecs Installed In This Computer

Choose from a drop-down list of the available codecs installed on the computer. Click Configure to choose from more recording options.

### Video Frames and Playing Time

- Seconds/Implant: Length of sequence for displaying each implant.
- Frames/Sec: Smoothness of the video.
- Total Play Time: Calculates the total play time for the options selected.

### Ending Logo

- Image File: Click Browse to select the location of the logo file.
- Add Logo: Select the checkbox to add in a logo segment to the movie.
- Duration: Set the length of time to show the logo.
- Background: Set the background color for the logo segment.

### Capture

Creates a video file from the selected sequence and video recording settings. Click Cancel to exit this dialog without recording the video.

## Implant: Settings and Preferences

Selecting the Preferences tool  opens up a customization window within the Implant Tab:

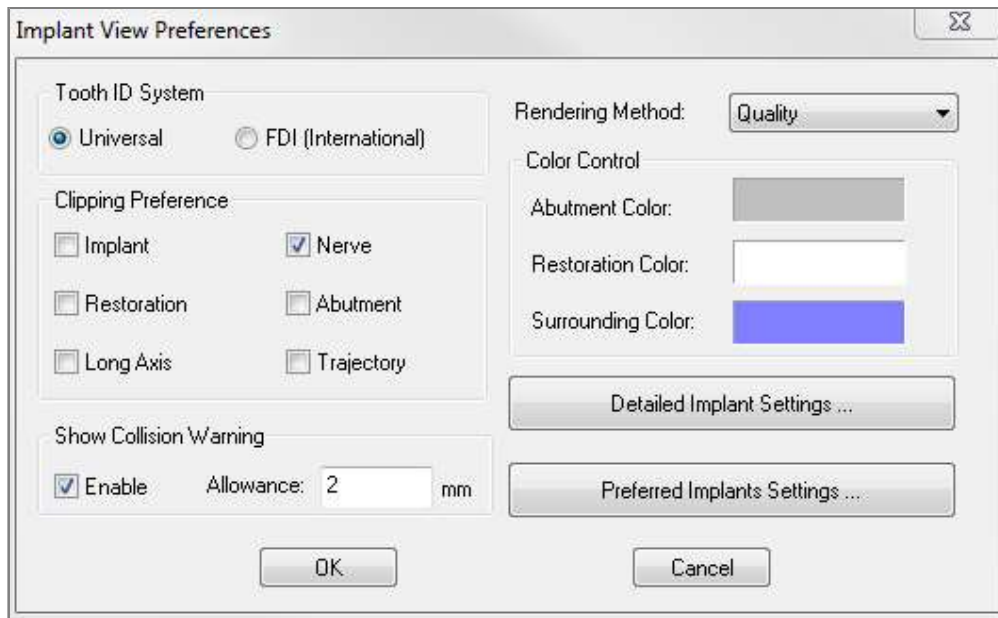

### Tooth ID System:

You can set the ID to either the Universal or FDI(International) standard.

### Clipping Preference:

Options for which models to include in volume clipping.

### Show Collision Warning:

You can define whether or not to display a proximity warning between implants at an allowed tolerance.

### Rendering Method:

Choose which rendering method (Default, Performance, and Quality) you would like to use in the Implant Tab.

### Color Control:

Set the various colors for the abutment, restoration, and collision colors.

### Detailed Implant Settings:

Adjust default settings for individual implants. See more information below.

### Preferred Implants Settings:

Used to modify which implants will be displayed in the drop-down menus in the Control Panel. See more information in the Preferred Implant Settings section (pg. 76).

### Detailed Implant Settings

When you select Detailed Implant Settings, you are able to adjust the default settings for individual implants in the Implant Planning Preference Window.

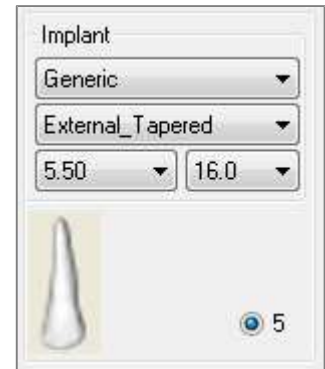

Clicking once anywhere in the region above will activate drop-down menus for the various implant characteristics. *Options will not appear for implants not in the preferred list (see below).*

Click OK to save these preferences and the designated implant will be selected automatically when choosing a tooth in the Add Single Implant menu.

### Preferred Implants Settings

The user can hide certain implants from populating the lists to simplify the drop-down menus. By default, all implant manufacturers and types are selected as “preferred.” **To remove an implant, select it in the list on the right-hand side and use the left arrow button to remove it from the list.**

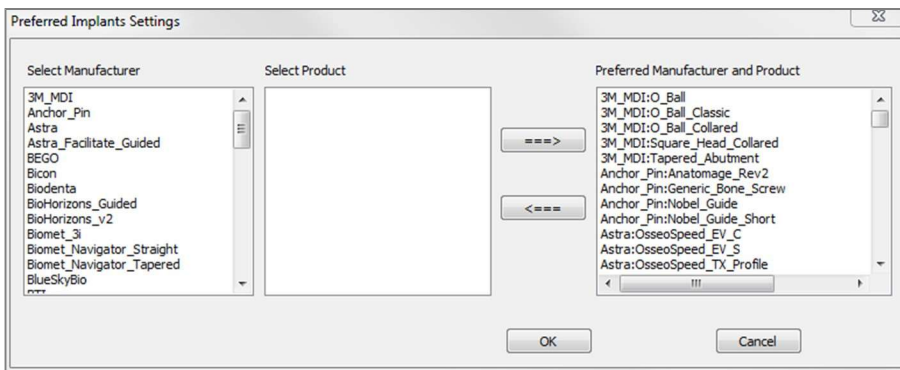

Settings will take effect in the drop-down menu options for Detailed Implant Settings as well as in the Implant section of the Control Panel. If there is a case open with implants that are not in the preferred list, the implant will still show up correctly in the renderers and the Control Panel. However, the specific settings for this implant cannot be changed and implants of the same type cannot be added.

Adding implants to the preferred list can be accomplished by selecting the implant manufacturer on the list on the left-hand side, selecting the specific product in the middle column, and pushing the right arrow button to add.

Certain manufacturers are divided into guided and non-guided subsets to indicate compatibility with the Anatomage Surgical Guide kits.

## Density Profile Control

By selecting the Density Profile Control tool  you can adjust the settings for the Density Profile.

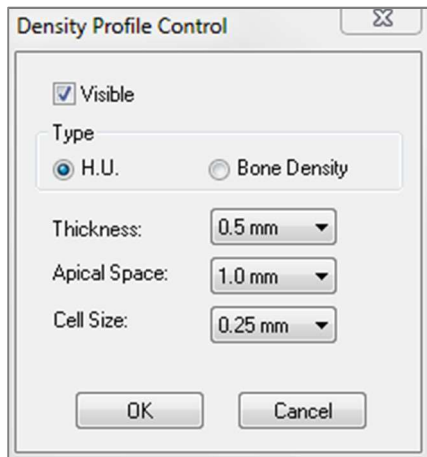

**Visible:** Toggles the visibility between the Density Profile and the third cross section.

**H.U.:** Shows the bone density in Hounsfield units.

**Bone Density:** Shows the density in Misch's bone density units.

**Thickness:** Changes the sampled volume located around the implant.

**Apical Space:** Changes the sampled volume located at the apex of the implant.

**Cell Size:** Changes how finely the voxels will be sampled and displayed in the volume around the implant.



Warning: Any measurement that is incorrect can lead to surgical complications if diagnosis, treatment plans and/or actual treatment is based on the incorrect measurements. It is critical for the end user to learn how to perform measurements correctly and employ proper usage of all measurement tools. Measurement accuracy depends on the image data and the hardware scanner that generated the image data. The measurement cannot be more precise than the resolution of the image. Software reports the value based on user-picked points. Due to the nature of medical imaging, the boundary is not always well defined. The apparent boundary depends on the current brightness and contrast setting. The boundary may shift as the user makes adjustments to brightness and contrast. The user must understand the limitation of the measurement value before applying to the patient. If you notice any inconsistencies or software problems with measurements, or have further questions or concerns about using measurement tools correctly, please contact us at (408) 885-1474 or email us at [info@anatomage.com](mailto:info@anatomage.com)



Warning: Any implant planning that is performed incorrectly in any aspect including but not limited to implant location, orientation, angle, diameter, length, and/or manufacture can lead to surgical complications if diagnosis, treatment plans and/or actual treatment is based off of the implant planning error(s) in question. It is critical for the end user to learn how to use the implant treatment planning tools correctly. If you notice any inconsistencies or software problems with implant planning or have further questions or concerns about correct utilization of implant planning, please contact Anatomage support at (408) 885-1474 or email us at [info@anatomage.com](mailto:info@anatomage.com)

# Restoration View Features

*The Restoration View Tab is an advanced tool that bridges the gap between implantology and restoration crown design. Users can register the stone models and add teeth directly or onto existing planned implants. With the model collision visibility options, numerous teeth libraries, and mesh editing features, this tab will guide implant surgery toward perfect occlusion.*

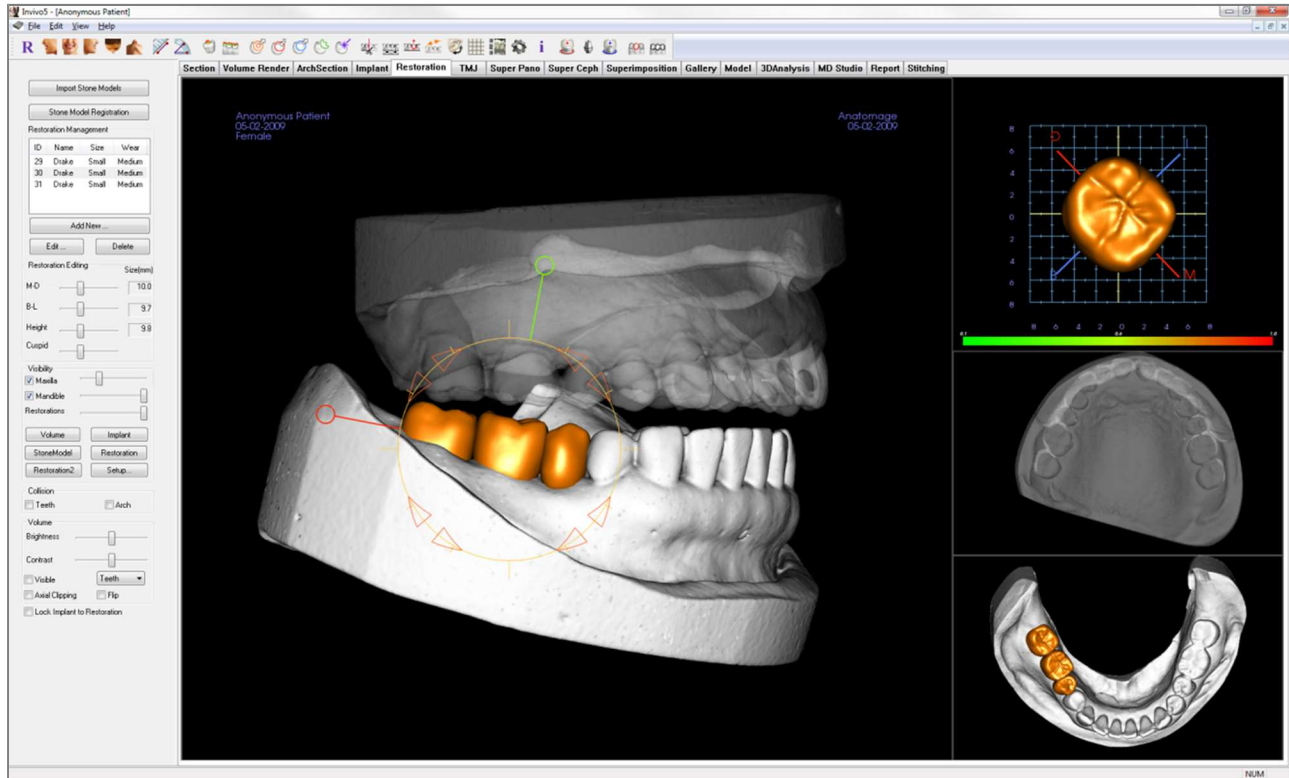

## Restoration: Toolbar

Shown below are the Toolbar and tools that are loaded with the Restoration View Tab:



Reset View: Resets the rendering window to the original view size.



Left View: Automatically orients the volume so the patient is facing left sagittal.



Frontal View: Automatically orients the volume so the patient is facing the front.



Right View: Automatically orients the volume so the patient is facing right sagittal.



Top View: Automatically orients the volume so you are oriented above the patient.



Bottom View: Automatically orients the volume so you are oriented below the patient.



Distance Measurement: Select this option and mark two points on the volume and distance will appear. Clicking on the point and moving the cursor can modify points. Click on the measurement and press the “delete” key to delete it. Control Panel features in Volume Render Tab allow the values to be projected to 2D, hidden, or exported to a report.



Angle Measurement: Select this option and mark three points on the volume and angle between them will appear. Clicking on their control points and moving the cursor can modify measurements. Click on the measurement and press the “delete” key to delete it. Control Panel features in Volume Render Tab allow the values to be projected to 2D, hidden, or exported to a report.



Show Collision: Turns on/off the collision between teeth restorations and the opposing/working stone models or restorations.



Show inter-arch collision: Turns on/off the visibility of collisions between the stone models.



Area Drag: Turns on the area drag tool in the rendering and the single tooth renderer windows.



Push Mesh: Turns on the push mesh tool in the rendering and the single tooth renderer windows.



Pull Mesh: Turns on the pull mesh tool in the rendering and the single tooth renderer windows.



Smooth: Turns on the smooth tool in the rendering and the single tooth renderer windows.



Auto collision resolution: Turns on the auto collision tool in the rendering and the single tooth renderer windows.



Plane Cutter: Activates a polygonal cutting tool to cut and close the mesh of stone models in the rendering window.



Cap Model: Applies a capping function to the available open mesh stone models.



Tooth extraction: Enables a polygonal mesh cutting tool for use on a stone model in immediate extraction cases.



Adjust occlusion: Turns on the stone model adjustment widget for manually moving the stone models and their dependent restorations in the rendering window.



Articulation: Opens the Articulation dialog to open/close the jaws with a simulated biting motion.



Toggle Grid: Turns on/off the 2D grid for simple assessment of size, measurement, and spatial location.



Change Layout: Toggles the rendering window layout.



Preferences: Opens the Preferences dialog for selecting color, collision, and default tool size settings.



Information Display: Displays or hides case information embedded in the data.



Fit to Margin: Opens a dialog to adjust the interface between a restoration and a prepped tooth on the stone model.



Custom Abutment: Opens a dialog that provides options for abutment design.



Fit to Custom Abutment: Opens a dialog to adjust the interface between a restoration and a custom abutment.



Create Pontic with Gingiva: Opens a dialog to modify the base of a pontic to fit to or offset from the stone model.



Create Bridge Connector between Selected Restorations: Creates a bridge linking all of the selected restorations. This bridge group can be deleted and converted back into the individual restorations.



**Warning:** Any measurement that is incorrect can lead to surgical complications if diagnosis, treatment plans and/or actual treatment is based on the incorrect measurements. It is critical for the end user to learn how to perform measurements correctly and employ proper usage of all measurement tools. Measurement accuracy depends on the image data and the hardware scanner that generated the image data. The measurement cannot be more precise than the resolution of the image. Software reports the value based on user-picked points. Due to the nature of medical imaging, the boundary is not always well defined. The apparent boundary depends on the current brightness and contrast setting. The boundary may shift as the user makes adjustments to brightness and contrast. The user must understand the limitation of the measurement value before applying to the patient. If you notice any inconsistencies or software problems with measurements, or have further questions or concerns about using measurement tools correctly, please contact us at (408) 885-1474 or email us at [info@anatomage.com](mailto:info@anatomage.com)



**Warning:** Any implants and restorations that are incorrectly visualized in Restoration Design Studio may lead to surgical complications or treatment delays. If you notice any inconsistencies or software problems with implant or restoration planning or have further questions or concerns, please contact Anatomage support at (408) 885-1474 or email us at [info@anatomage.com](mailto:info@anatomage.com)



## Restoration: Control Panel

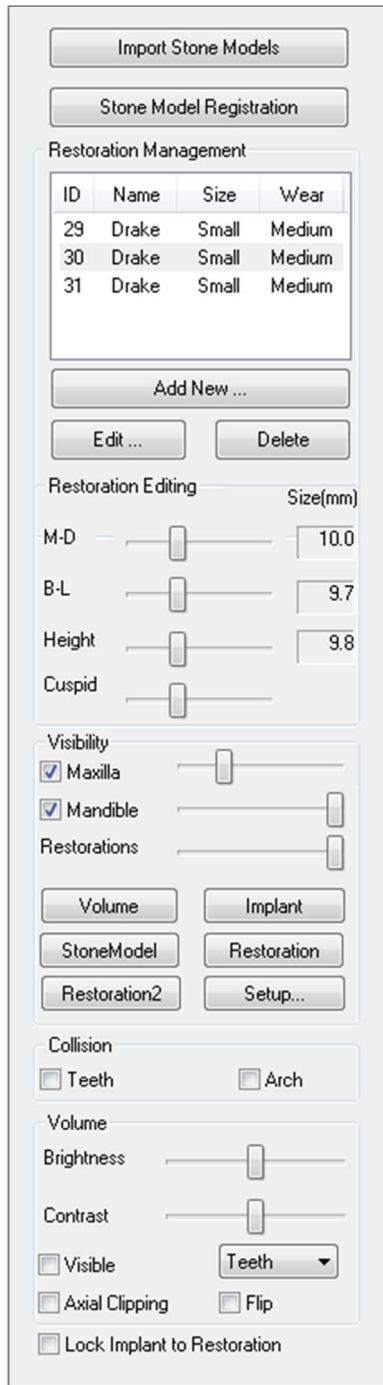

### Volume

- Brightness & Contrast: Can be adjusted for each of the presets to enhance your image.
- Visible: Turns on/off the visibility of the DCM volume.
- Axial Clipping: Turns on/off axial clipping and the Axial Clipping widget.
- Rendering (drop-down): Chooses the rendering preset between the options of Teeth and Bone.
- Flip: Flips the clipping direction.

Lock Implant to Restoration: When selected, the implant and restoration will move as a single unit.

### Import Stone Models

Initiates a sequence of steps to import and register a stone model. For more information, see the Restoration: Stone Model Registration section (pg. 82).

### Stone Model Registration

Opens the Register Stone Models to Volume dialog to restart the registration for the imported stone models.

### Restoration Management

- Add New...: Opens the teeth library for restoration selection and placement.
- Edit...: Opens the teeth library to change the currently selected restoration.
- Delete: Removes the currently selected restoration from the rendering window.

### Restoration Editing

- M-D Size(mm): Adjusts the mesiodistal dimension of the restoration.
- B-L Size(mm): Adjusts the buccolingual dimension of the restoration.
- Height Size(mm): Adjust the height of the restoration.
- Cuspid: Adjusts the cusp dimensions from low to high.

### Visibility

- Maxilla: Adjust the visibility/opacity of the maxilla.
- Mandible: Adjust the visibility/opacity of the mandible.
- Restoration: Adjusts the opacity of the restorations.
- Setup: Opens a dialog where the view presets can be configured.
- Presets: Preset toggles that display the selected features as configured in the Setup.

### Collision

- Teeth: Turns on the visibility of collisions between the restorations and the opposing/working stone model or restorations.
- Arch: Turns on the visibility of collisions between the stone models.

## Restoration: Stone Model Registration

The Import Stone Model function will guide you step-by-step through the importing and registration of upper and lower stone models. If stone models are already present in the workup, this function will serve to replace the existing models.

### Step 1: Import Stone Models

- Click Import Stone Models in the Control Panel.
- Choose the .stl or .ply file in the Select Stone Model File dialog.
- Select the type of model as Upper (maxilla) or Lower (mandible).
- Move onto the next step. At the end of registration, click Import Stone Models once more if the opposing stone model needs to be imported or if a stone model registration needs to be redone.

### Step 2: Select Type of Registration

- **Maintain Position:** The software will apply the transformation data from the registration of the opposing arch to this STL. This option is useful if a pair of STLs (upper and lower) have been registered in another program (intraoral scans may have close bite registration data). In this case, after registering one STL to the DCM (see Register to CT), the second STL can be imported and be loaded so that the close bite registration is restored. This will most likely result in an incorrect position relative to the DCM scan for the second STL, since many CBCT scans intended for implant/restorative workups are taken with open patient bites.
- **Register to CT:** This will initiate the first step in registering the STL file to the DCM. The dialog (right, lower) shows the three steps needed to complete the registration. The layout (Figure 1) shows the STL on the left of the rendering window and the DCM on the right with the adjacent clipping tool. Click Help to read the embedded document describing how to register different cases.
  - **Clean Scan:** Check this option when the case has little to no scatter. The registration will use additional points where selected for a more accurate registration.
  - **Restart:** Resets the user back to Step 1 in the dialog.
  - **Perform Registration:** Matches the STL to the DCM based on the points selected.
  - **Done:** Closes the dialog.

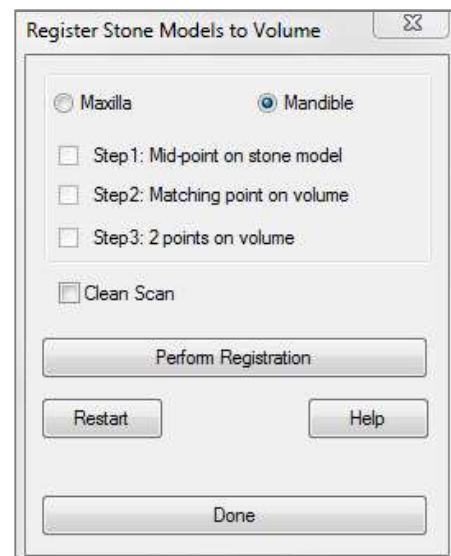
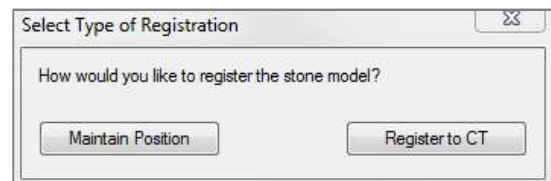
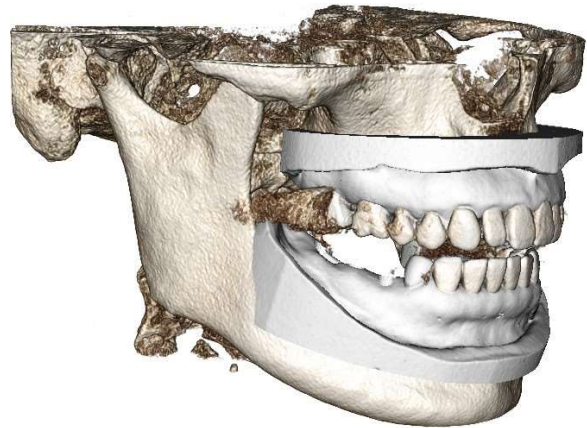

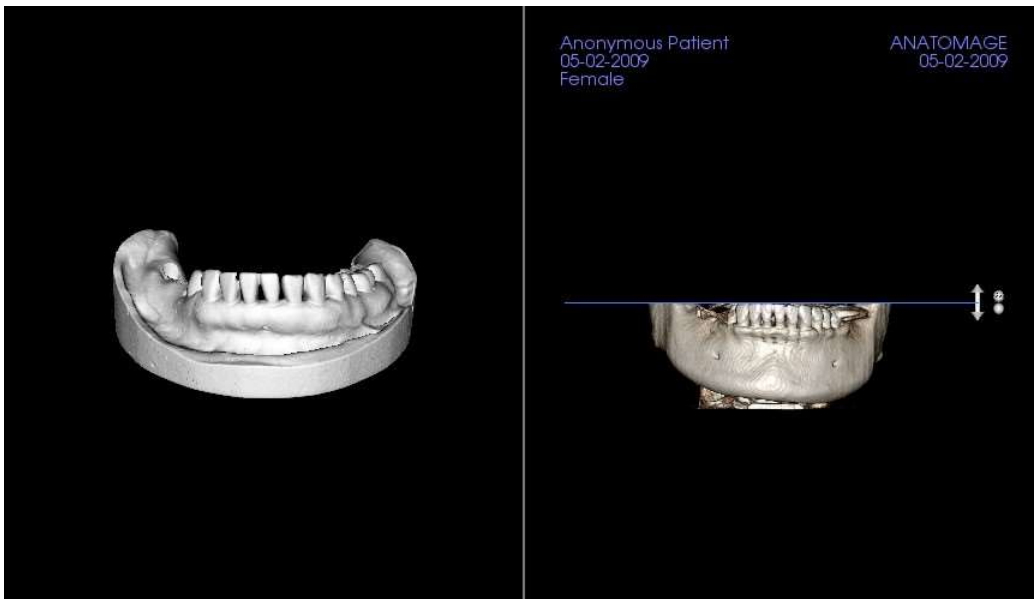

Figure 1

- After clicking Perform Registration, the user will be brought to a new layout (Figure 2), which features two volume renderers and three grayscale slice renderers. Use the yellow arrows in the DCM renderer to center the mid-point in the correct position at the front of the scan. After verifying this point in the sagittal grayscale renderer, continue using the other widget arrows and slice renderers to rotate the STL around this mid-point and achieve the proper orientation.

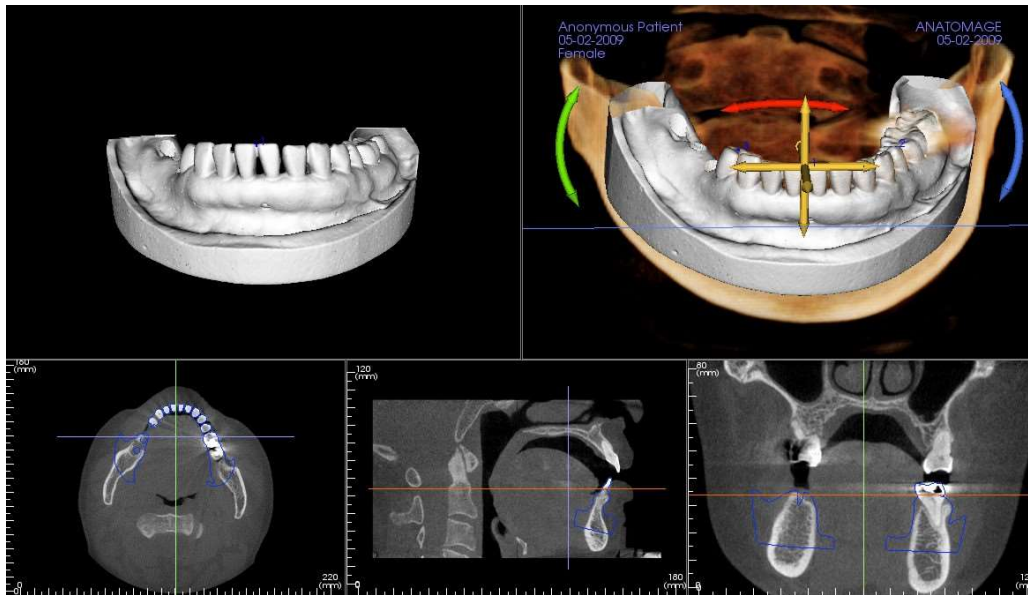
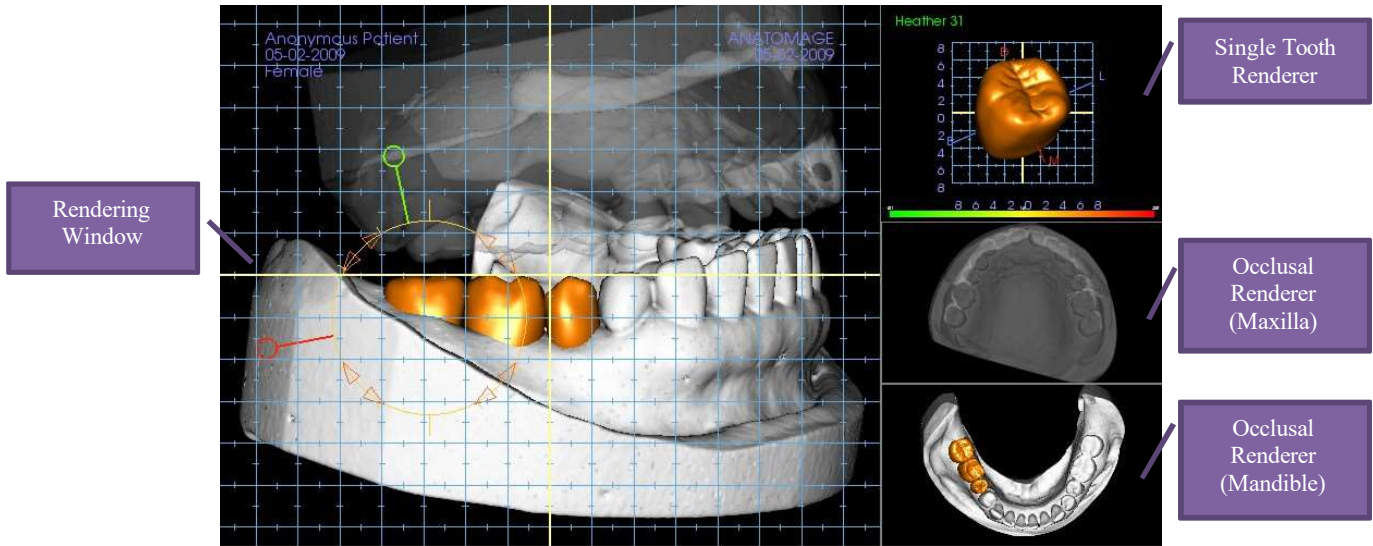

Figure 2

## Restoration: Rendering Window & Mesh Manipulation



### Rendering Window:

- Displays the stone models, restorations, patient volume, implants, and skin models.
- The restoration can be moved by first left-clicking to select the tooth and then left-clicking and dragging the model to a new location from any view. The angle in which the tooth is viewed determines the plane on which the restoration will translate.
- All the mesh editing functions except Auto collision resolution will function in this window.
- Plane cutter, Cap model, Tooth extraction, Adjust occlusion, and Articulation can be performed in this window.

### Single Tooth Renderer:

- The tooth model can be independently rotated and zoomed in this view. Clicking on the D (distal), M (mesial), B (buccal), or L (lingual) letters will move the restoration in short steps in the selected direction within the rendering window.
- The tooth library type and tooth number will be displayed in the upper left.
- The color scale at the bottom will indicate the depth of the collision with the opposing stone model when "Tooth collision" is activated. The interval for depth(mm) is set to 0.1 to 2mm and can be changed in the Preferences.
- All mesh editing functions including Auto collision resolution will function in this window.

### Occlusal Renderer (Maxilla and Mandible):

- These renderers will display the STL models, restorations, and the collisions (depth or boundaries) between them. It is intended for viewing purposes and the models cannot be zoomed or rotated but opacity changes will take effect.

## Restoration: View Preset Setup

Visibility presets allow for easy switching between set views during implant planning. To configure these settings, click on Setup. These presets may also be modified in the Implant Tab.

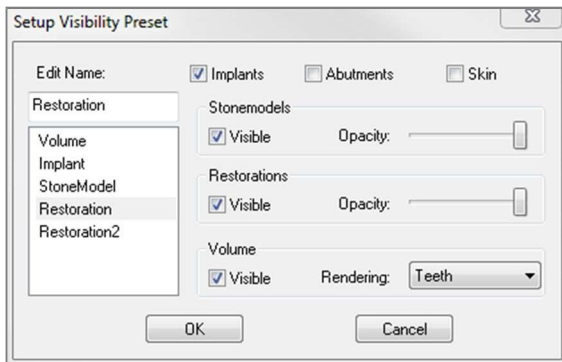

- Edit Name: Click on any preset to select it. Type the new name into the field.
- Visibility checkboxes hide or show features in the rendering window.
- Implants: Toggles the visibility of the implants.
- Abutments: Toggles the visibility of the abutments.
- Skin: Toggles the visibility of the face photo wrap from the Anatomodel workup file or 3DAnalysis.

- Stonemodels: Controls the visibility of the stone models. Varying degrees of transparency can be obtained with the Opacity slider.
- Restorations: Controls the visibility of the 3D waxup models in the volume renderer and the colored profile in the 2D section renderer. The colored profile of the selected restoration or restoration associated with the selected implant will be red while the unselected restorations will be pink. Varying degrees of transparency can be obtained with the Opacity slider.
- Volume: Controls the visibility of the volume render as well as the rendering type.

## Restoration: Abutment Planning

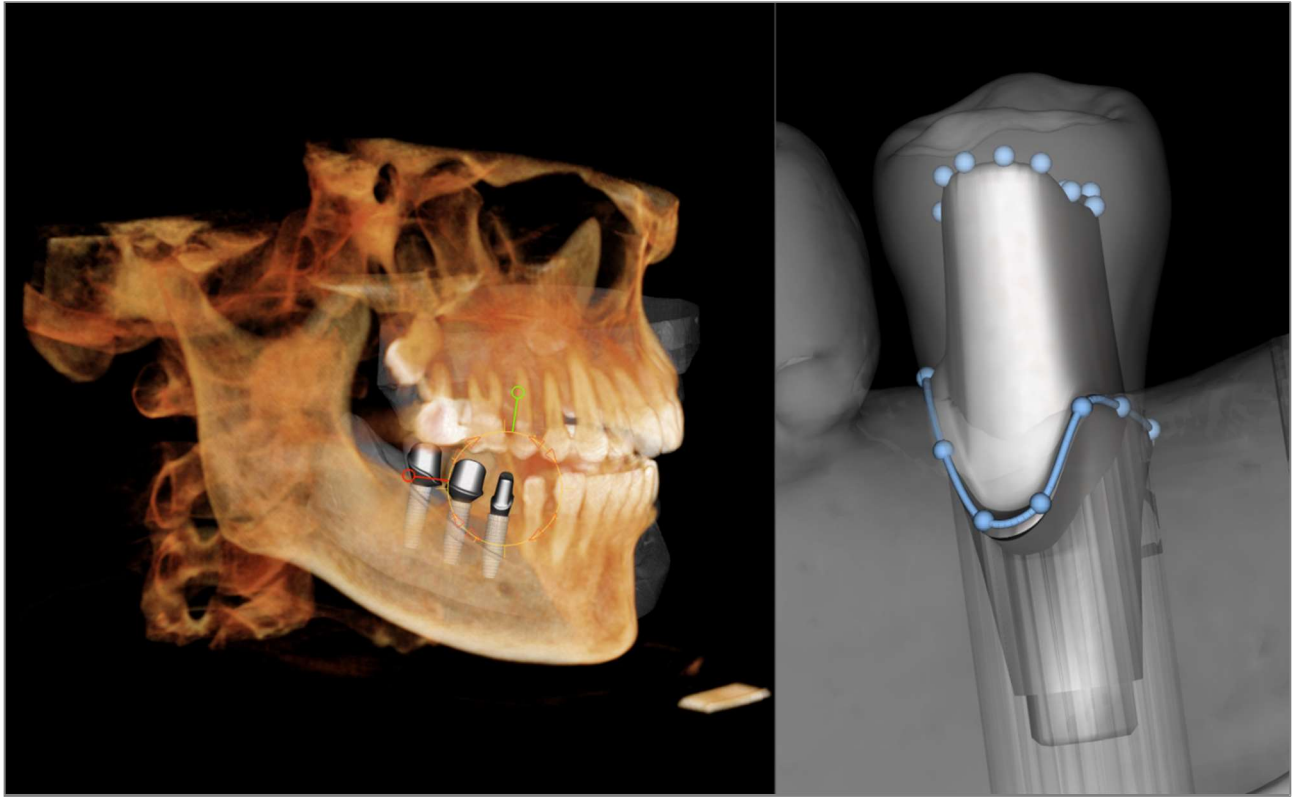

- The abutment automatically connects the restoration model with the implant model in the rendering window. The currently selected abutment will be displayed enlarged on the right side.

## Restoration: Abutment Planning Dialog

### Abutment Parameters

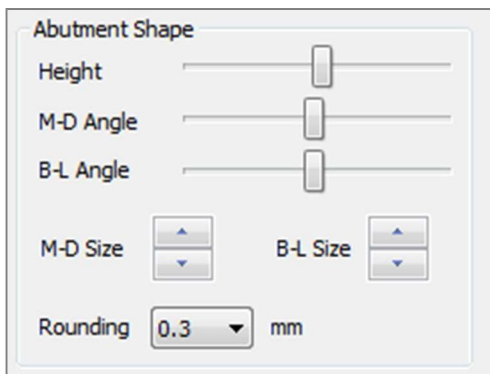

### Top Shape

- Height: Adjusts the length of the abutment.
- M-D Angle: Adjusts the mesiodistal angle.
- B-L Angle: Adjusts the buccolingual angle.
- M-D Size: Adjusts the mesiodistal size.
- B-L Size: Adjusts the buccolingual size.
- Rounding: Adjusts the rounding of the abutment.

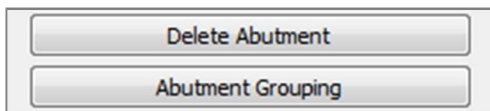
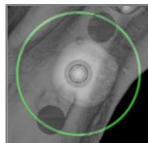
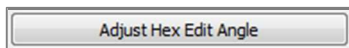
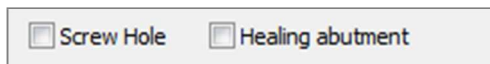
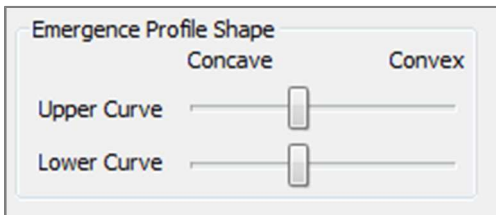
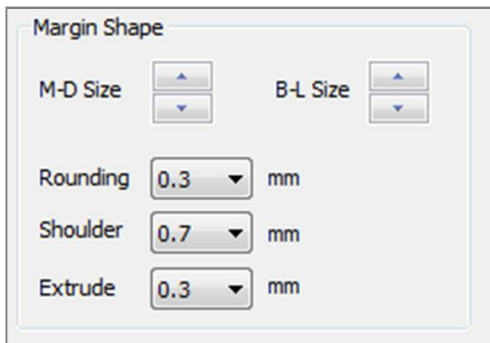

### Margin Shape



- M-D Size: Adjusts the mesiodistal size.
- B-L Size: Adjusts the buccolingual size.
- Rounding: Adjusts the rounding of the margin.
- Shoulder: Adjusts the margin between the axial (abutment) tooth surface and finish line.
- Extrude: Adjusts the size of the finish line shape.

### Emergence Profile Shape

- Top Curve: Adjusts the shape of the upper portion of the abutment base.
- Bottom Curve: Adjusts the shape of the lower portion of the abutment base.
- Screw Hole: Adds a screw hole that exits through the top and bottom of the abutment.
- Healing abutment: Replaces the current abutment with a healing abutment.
- Adjust Hex Edit Angle: Inserts a new widget into the renderer to allow rotation of the hex.
- Finish Editing Hex Index Angle: Removes the widget from the renderer.
- Delete Abutment: Removes the selected abutment.
- Abutment Grouping: Opens a dialog where abutments can be grouped such that their insertion angles will be parallel.

## Restoration: Crown Types

### Crowns for prepped teeth or custom abutments

When using the Fit to Margin tool  or the Fit to Custom Abutment tool , the Build Crown dialog will appear. This dialog allows you to adjust the base of the restoration to interface optimally with the prepped tooth or abutment.

### Cement Gap

- Thickness (mm): The distance between the interior of the restoration and the top surface of the prepped tooth or abutment.
- Distance To Margin (mm): The distance between the inner and outer edge of the restoration at the shoulder.

### Undercut/Blockout

- Show undercut regions: Highlights the undercut regions in red.
- Blockout undercut regions: Removes undercut regions by adjusting the restoration.
- Align Insertion Axis with Tooth: This option is only available for prepped teeth. Select the appropriate tooth to align the insertion axis of the restoration.

### Restoration Border

- Width (mm): Width of the restoration border at the shoulder.
- Angle (deg): Angle of the restoration border.
- Edge (mm): Length of the edge of the restoration border.
- Height (mm): Height of the restoration border.

Enable Margin Editing: This option is only available for prepped teeth. Adjust the margin tracing around the prepped tooth.

Build Crown: Calculates and updates the shape of the restoration base.

Cancel: Exits the dialog.

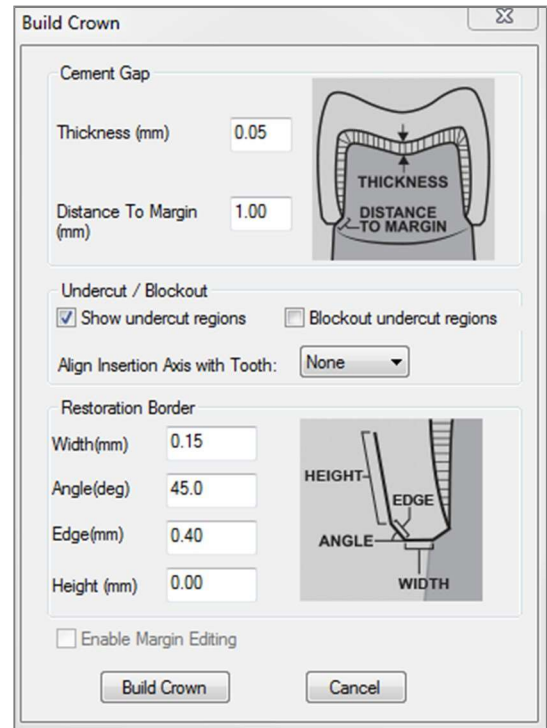

### Pontics

Pontic restorations will sit a set distance above the stone model can either retain its original design shape or be fit to the stone model's surface. Click to select the restoration of interest and then click the Create Pontic with

Gingiva tool .

Offset from gingiva: Distance between the bottom of the restoration and the stone model.

Type:

- Fitted: The bottom of the restoration will be reshaped to fit the contour of the stone model.
- Scaled: The restoration size will be scaled such that the bottom is the appropriate offset distance from the stone model.

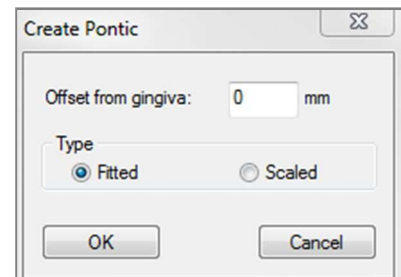



## Bridges

Select a set of restorations by “Ctrl” + right-clicking each restoration. Click the Create Bridge Connectors between Selected Restorations tool  to create a bridge.

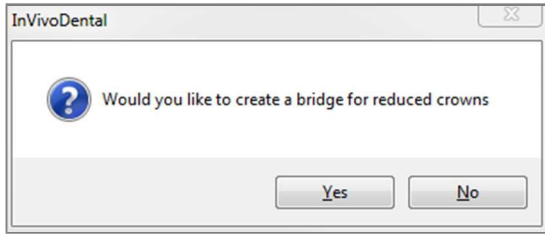

Choose Yes to create a bridge for reduced crowns. This bridge will have editable connectors.

Choose No to create a bridge that links the restorations but does not have connectors.

Restorations cannot be manipulated individually or moved after bridge creation.

If a bridge for reduced crowns was created, each connector may be edited individually. Click on the connector to select it and open the Bridge Connector Options and display the editable nodes.

### Bridge Connector Options

**Cross Section Shape:** Choose the shape of the cross section of the connector.

**End Diameter:** Set the diameter of the ends of the connector that contact the adjacent restorations.

**Middle Diameter:** Set the diameter of the middle of the connector.

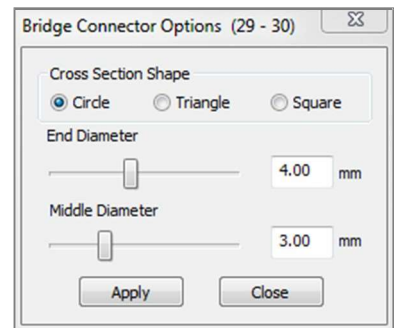

**Warning:** Incorrect crown fitting may cause inaccurate crown shape and positioning. This may lead to surgical complications or delays if treatment planning.

## Restoration: Articulation and Adjust Occlusion

### Articulation

For best results, first adjust the occlusion using the Adjust Occlusion tool . The Articulation function will determine a closed-bite orientation for the two STL models and define an occlusal plane. The STL models can then be opened, closed, or slid across each other to simulate anatomical jaw operations. (The closed-bite registration is determined by a best-fit of the two STLs during specified interactions.)

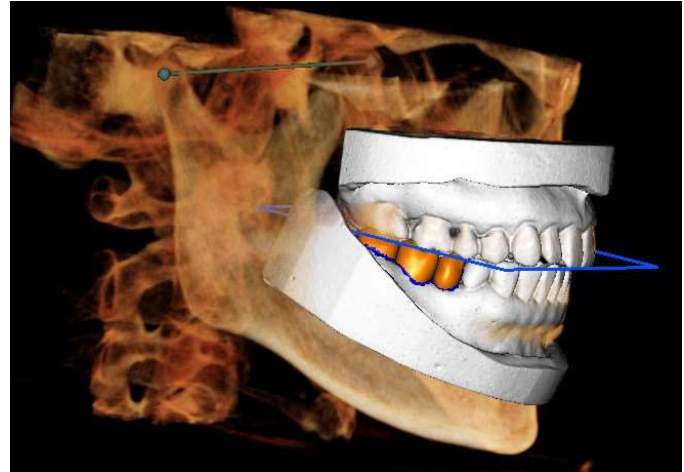

Activation of this feature will turn on:

- A widget for editing the position of the condyles as well as displaying the occlusal plane. The condyle handles can be left-clicked and dragged to the correct positions.
- The Articulation dialog box (below).

### Articulation Dialog

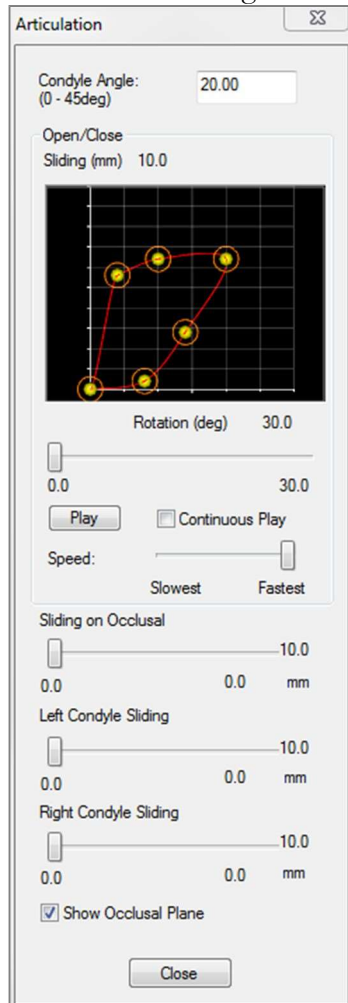

### Condyle Angle

This determines the angle of the plane below the occlusal plane on which the mandible STL will slide. (Example: if the Condyle Angle is set to 0 deg, the mandible will slide on the occlusal plane.)

### Movements

- Open/Close Graph: Changes the angle of “jaw” opening and degree of rotation during the articulation animation.
- Sliding on Occlusal: Slides the mandible along the occlusal plane with an adjusted angle determined by the Condyle Angle.
- Left Condyle Sliding: Slides the left condyle forward along the occlusal plane with an adjusted angle determined by the Condyle Angle.
- Right Condyle Sliding: Slides the right condyle forward along the occlusal plane with an adjusted angle determined by the Condyle Angle.
- Show Occlusal Plane: Displays the blue frame of the occlusal plane in the rendering window.

### Close

Closes the dialog box and returns the STLs and restorations to the original registered position.

## Restoration: Preferences

Selecting the Preferences tool  opens up a customization window within the Restoration Tab:

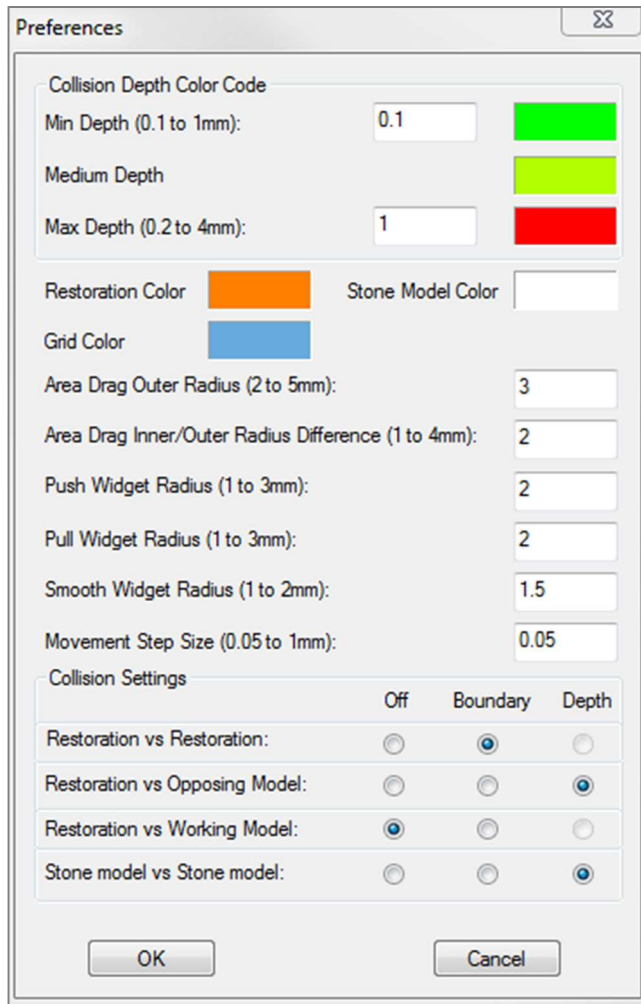

### Collision Depth Color Code

- **Min Depth:** Sets the minimum mesh collision depth for detection and the color corresponding to minimal collision.
- **Medium Depth:** Sets the color corresponding to the medium level of collision based on the depth range.
- **Max Depth:** Sets the level of collision detected as maximal and the corresponding color.

### Other Settings

- **Restoration color:** Sets the color of the restorations.
- **Stone Model Color:** Sets the stone model color
- **Grid Color:** Sets the color of the grid on the individual restoration renderer as well as the Toggle Grid tool.
- **Area Drag Outer Radius:** Sets the default Area Drag tool's outer radius of effect. Area can still be adjusted using the mouse scroll wheel when the tool is in use.
- **Area Drag Inner/Outer Radius Difference:** Defines the inner circle of the Area Drag tool. The inner circle directly experiences drag whereas the area of the outer circle gets subsequently deformed by the drag force.

- **Push Widget Radius:** Sets the default Push Mesh tool's radius of effect. Area can still be adjusted using the mouse scroll wheel when the tool is in use.
- **Pull Widget Radius:** Sets the default Pull Mesh tool's radius of effect. Area can still be adjusted using the mouse scroll wheel when the tool is in use.
- **Smooth Widget Radius:** Sets the default Smooth tool's radius of effect. Area can still be adjusted using the mouse scroll wheel when the tool is in use.
- **Movement Step Size:** Adjusts the amount the selected restoration moves using the arrow keys.

### Collision Settings

- **Off:** Collision between the structures will not be shown.
- **Boundary:** Shows only the boundary of collision in blue.
- **Shows the depth of collision in the range of colors set in the Collision Depth Color Code section.**

# TMJ View Features

*In the TMJ View Tab you can view the TMJ region with two independent focal troughs allowing you to get cross sections of each TMJ in one view, along with corresponding coronal and axial views. The TMJ View Tab also lets you see the TMJ in 3D volume renderings with automatic segmentation.*

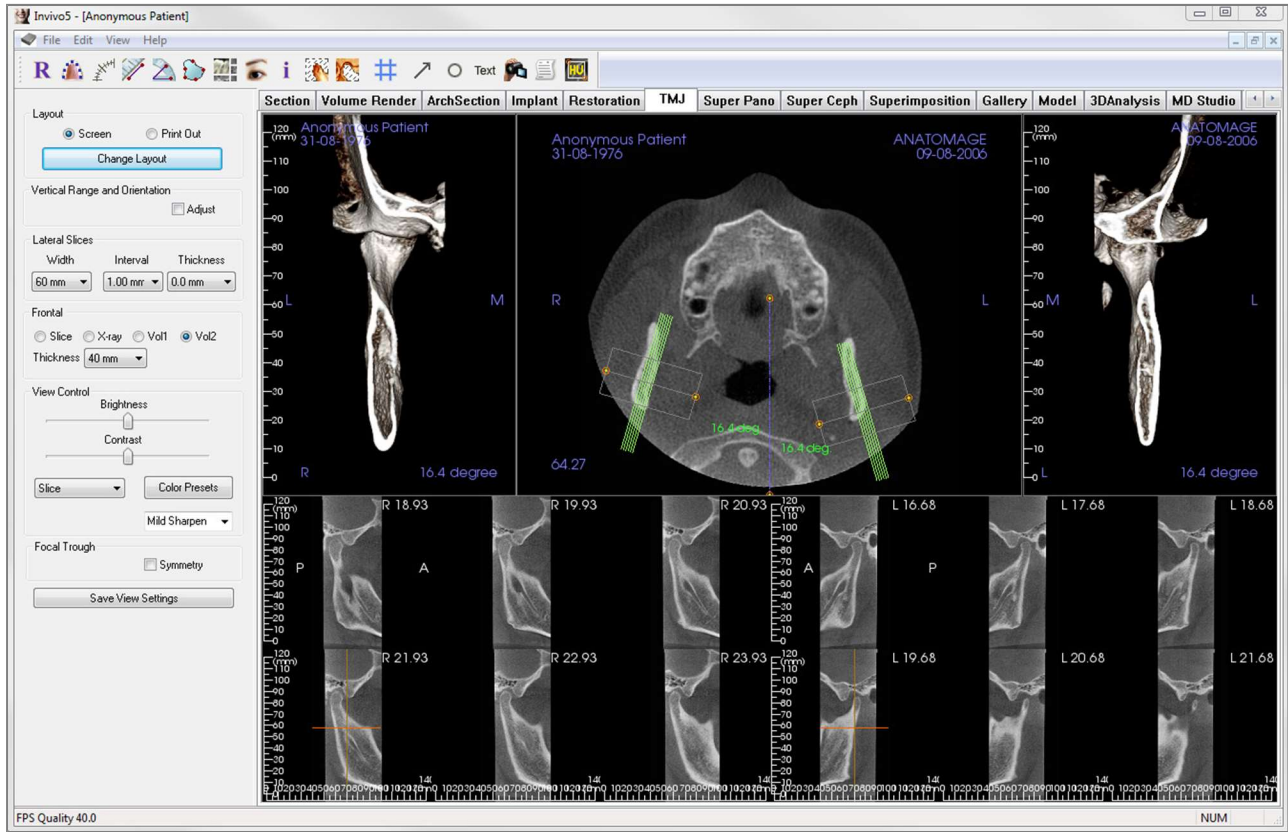

## TMJ: Toolbar

Shown below are the Toolbar and tools that are loaded with the 'TMJ View Tab':

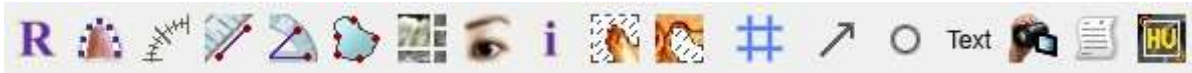

Reset View: Resets the rendering window to the original view.



Create Arch Spline (Focal Trough): Select this tool to create or edit the arch spline. Left-click to place the first point and continue left-clicking along the arch. After you have marked your final point, right-click or double-click to finalize the arch spline. When modifying an existing arch spline, drag the control points to the desired positions.



Arch Spline (Focal Trough) Ruler: Places ruler along the arch spline for easy reference.



Distance Measurement: After selecting this tool, click two points to mark the desired distance. A number in millimeters will automatically display.



Angle Measurement: After selecting this tool, click the first point, then click the vertex, then click the last point to create an angle. A number in degrees will automatically display.



Area Measurement: After selecting this tool, click multiple points along the boundary of the desired area. Double-click or right-click to end the measurement. A number in millimeters squared will be automatically displayed.



Layout: Creates a different layout to your preference. After clicking on the layout icon, a list of various layout options will appear. Click on the layout of your preference to apply it. These options allow for different case workup images. In this window, you can also choose how many millimeters you want the cross-section interval to be. If you choose 1.0 mm, for example, there will be a space of 1.0 mm between each cross section.



Show/Hide Cursor/Implant/Nerve: Conceals or displays cursors.



Information Display: Displays or hides case information embedded in the data.



Condyle Segment: Allows for automatic segmentation of the condyle in 3D.



Fossa Segment: Allows for automatic segmentation of the mandibular fossa in 3D.



Positioning #: Allows for a positioning grid to toggle on/off the cross sections.



Arrow Notation: Allows an arrow to be drawn on the image.



Circle Notation: Allows a circle to be drawn on the image.



Text Notation: Allows text to be written and edited on the image.



View Sequence: Allows for the creation of custom camera sequences and AVI file movie capturing. Refer to the Volume Render View Sequence (pg. 52) section for additional information and description.



**Slice Capture Mode:** Opens the Slice Capture Manager to enable the capture of slices or groups of slices from a series of cross sections. Requires the creation of a slice group in the Report Tab. Requires an activated Report module.



**Select Region:** Calculates the HU value of an area within a bounding box. The measurements will display alongside the rectangle and can also be repositioned by dragging.



Warning: Any measurement that is incorrect can lead to surgical complications if diagnosis, treatment plans and/or actual treatment is based on the incorrect measurements. It is critical for the end user to learn how to perform measurements correctly and employ proper usage of all measurement tools. Measurement accuracy depends on the image data and the hardware scanner that generated the image data. The measurement cannot be more precise than the resolution of the image. Software reports the value based on user-picked points. Due to the nature of medical imaging, the boundary is not always well defined. The apparent boundary depends on the current brightness and contrast setting. The boundary may shift as the user makes adjustments to brightness and contrast. The user must understand the limitation of the measurement value before applying to the patient. If you notice any inconsistencies or software problems with measurements, or have further questions or concerns about using measurement tools correctly, please contact us at (408) 885-1474 or email us at [info@anatomage.com](mailto:info@anatomage.com)

## TMJ: Control Panel

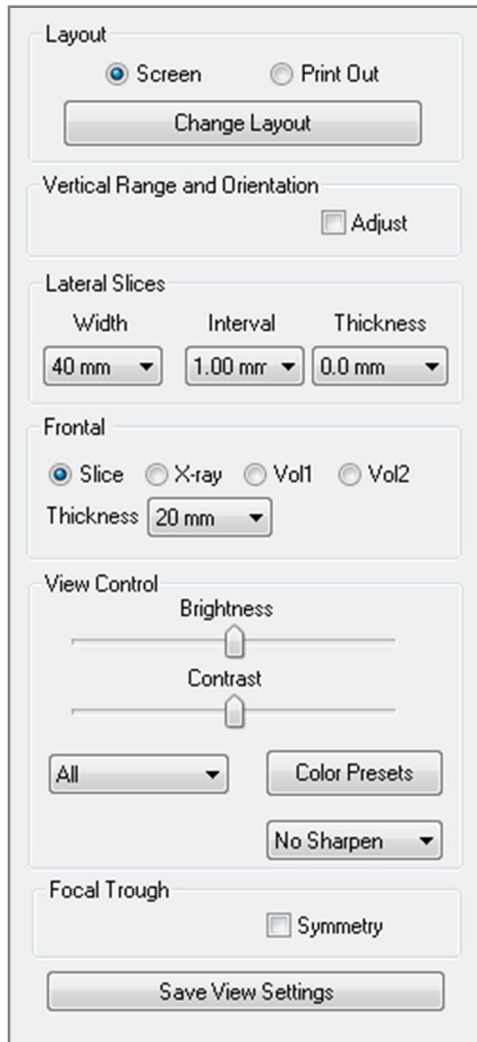

### Layout

- “Screen” mode shows the rendering window in full size but not life size.
- “Print Out” mode shows the image in life size and allows you to capture and print in life size.
- Change Layout: Lets you switch to different layout orientations.

### Vertical Range and Orientation

Select “Adjust” to change the rendered volume range and orientation.

### Lateral Slices

- “Width” allows you to change the width of the slices.
- “Interval” allows you to change the interval between the cross-sectional slices.
- “Thickness” allows you to add multiple slices together for ray sum visualizations.

### Frontal

- This lets you adjust the view visualizations of the coronal slices of the TMJ.
  - Slice – Gray Scale rendering
  - X-ray – X-ray rendering
  - Vol1 – Teeth rendering
  - Vol2 – Bone rendering
- Using the Thickness drop-down, you can create a ray sum view.

### View Control

- Brightness and Contrast allow you to adjust the image.
- The “All” drop-down allows you to adjust brightness/contrast in different areas independently.
- Color Presets can be used to view the images in different colors.
- Sharpening Filter: Applies the selected sharpening filter from the drop-down menu to the 2D slice renderers.

### Focal Trough

Click on the “Symmetry” box to keep the focal trough angles symmetrical.

### Save View Settings

Saves the current 2D View settings to be reloaded upon opening any case. See the Display Preferences section in Preferences for more information on which settings are saved for this specific tab (pg. 19).

## TMJ: Rendering Window

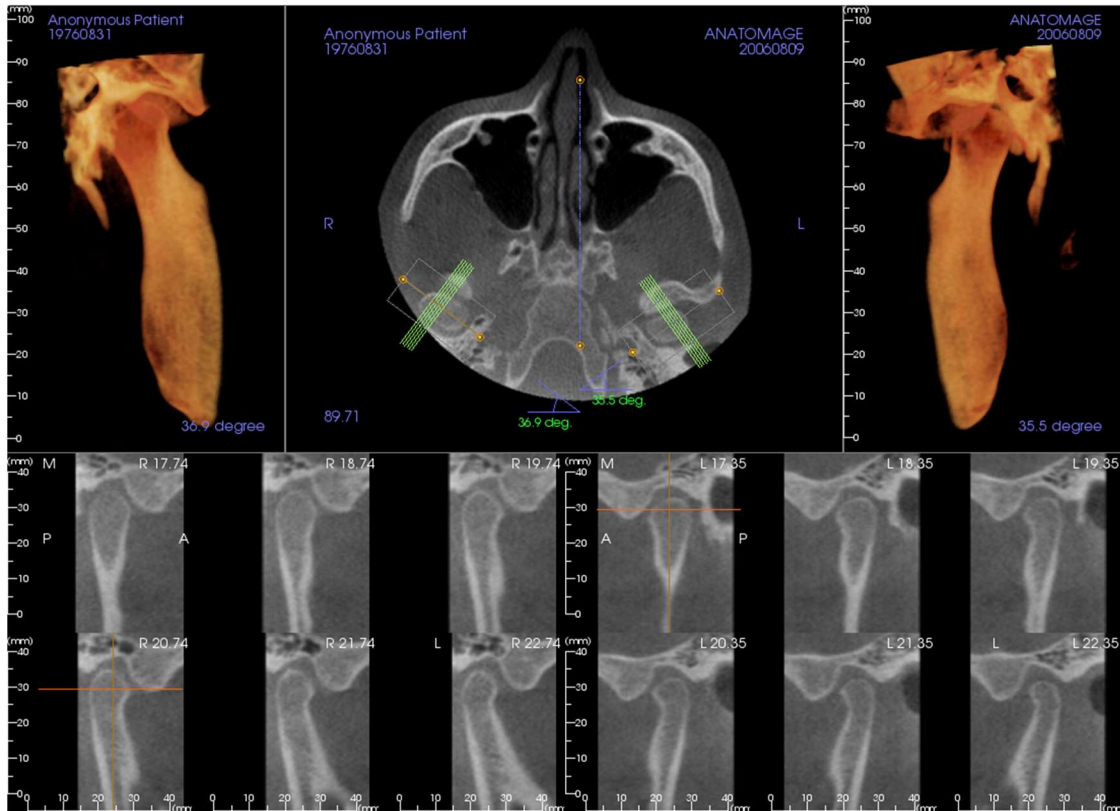

Please refer to [Image Navigation \(pg. 32\)](#) for information about controlling and adjusting these images.

### Arch Spline (Focal Trough) Navigation

- Endpoints: Clicking and dragging either endpoint of the focal trough can shorten/lengthen the focal trough or rotate the focal trough, depending on the direction that it is dragged.



**Warning:** Sequence direction depends on the focal trough direction. Medial and lateral may be flipped if the focal trough angle is in the opposite direction.

- Cross Section Indicators: Clicking and dragging the stack of green lines will scroll the cross sections through the focal trough in that direction.
- Focal Trough Box: Clicking and dragging any one of the lines forming the shape of the focal trough will move the entire focal trough.



## TMJ: Layout

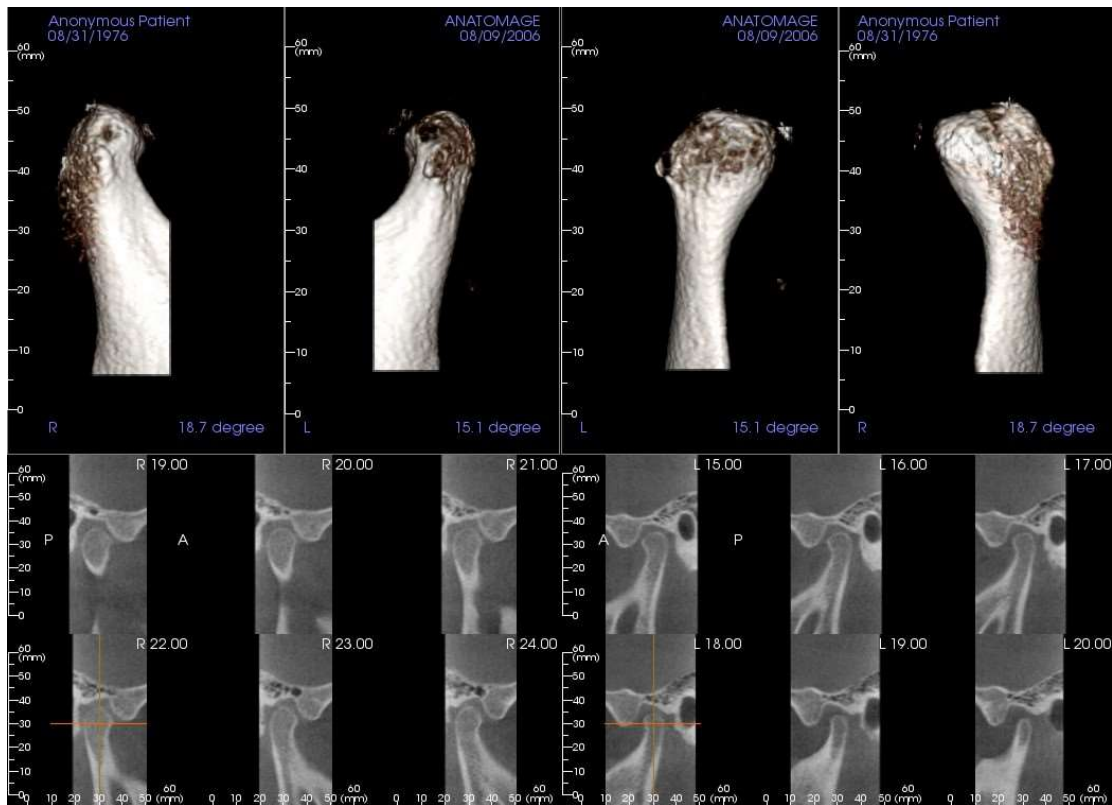

Many of the various layout options of the TMJ Tab feature frontal views of the condyle. Some layout features include:

- Two frontal volume views for each condyle, as seen above.
- Free rotation of the volumes after Vol1 or Vol2 have been activated.
- Sculpting operations carry over from Volume Render: The condyles can be segmented out using sculpting tools in the Volume Render Tab. These operations are carried over automatically to the TMJ Tab.

# Super Pano View Features

*The Super Pano View Tab gives you the ability to construct and view an enhanced version of a panoramic radiograph, take measurements, and utilize several image enhancement features. It also has the ability to render a pano into a volumetric 3D image that can be rotated for greater visual advantages.*

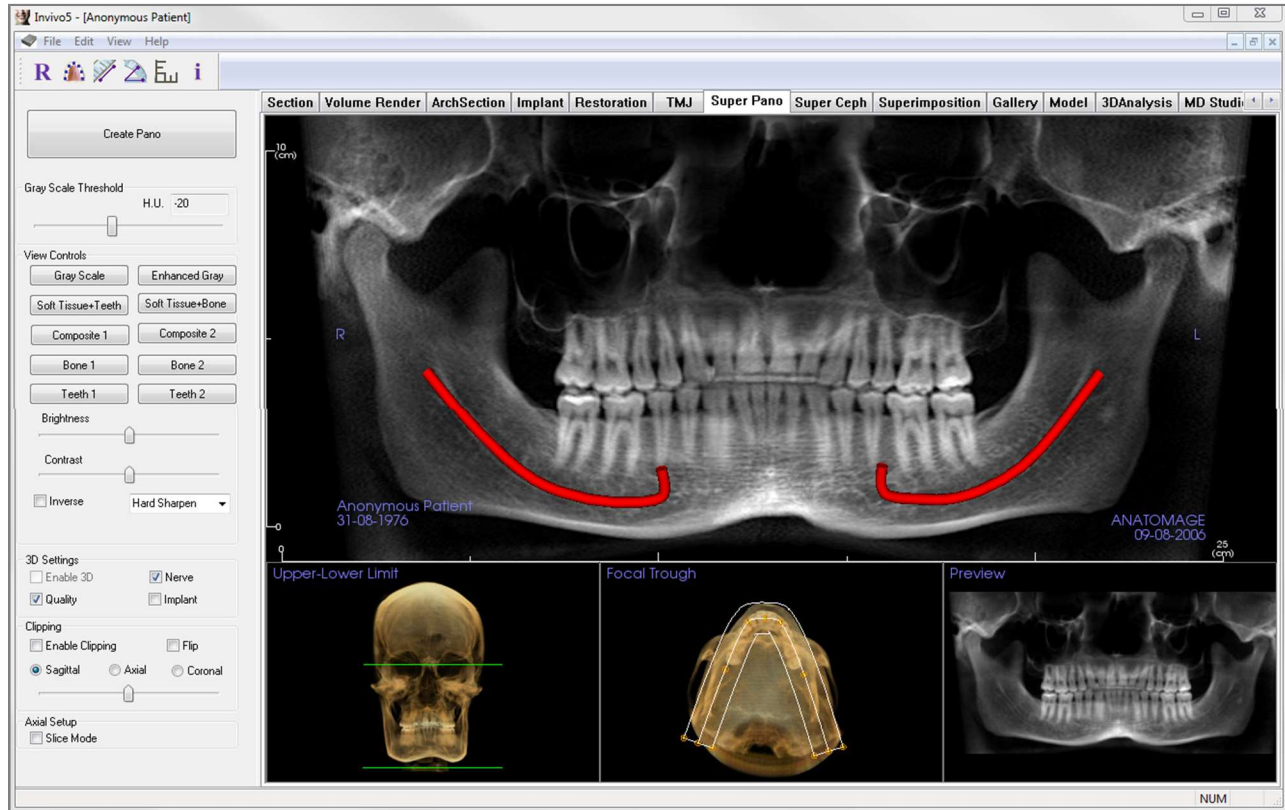

## Super Pano: Toolbar

Shown below are the Toolbar and tools that are loaded with the Super Pano View Tab:



Reset View: Resets the rendering window to the original view.



Create Focal Trough: Sets the boundaries of the Super Pano. A focal trough is automatically set but can be adjusted or recreated entirely. Use the yellow dots to stretch, widen, or reshape the focal trough. The focal trough selects only the objects you want to appear in the Super Pano and excludes others such as the spine, which traditionally appears in panoramic radiographs as background noise.



Distance Measurement: After selecting this tool, click two points to mark the desired distance. A number in millimeters will automatically display.



Angle Measurement: After selecting this tool, click the first point, then click the vertex, then click the last point to create an angle. A number in degrees will automatically display.



Grid: Toggles between two different grid layouts for use in all of the section frames allowing quick assessment of measurements and spatial location.



Information Display: Displays or hides case information embedded in the data.



**Warning:** Any measurement that is incorrect can lead to surgical complications if diagnosis, treatment plans and/or actual treatment is based on the incorrect measurements. It is critical for the end user to learn how to perform measurements correctly and employ proper usage of all measurement tools. Measurement accuracy depends on the image data and the hardware scanner that generated the image data. The measurement cannot be more precise than the resolution of the image. Software reports the value based on user-picked points. Due to the nature of medical imaging, the boundary is not always well defined. The apparent boundary depends on the current brightness and contrast setting. The boundary may shift as the user makes adjustments to brightness and contrast. The user must understand the limitation of the measurement value before applying to the patient. If you notice any inconsistencies or software problems with measurements, or have further questions or concerns about using measurement tools correctly, please contact us at (408) 885-1474 or email us at [info@anatomage.com](mailto:info@anatomage.com)

## Super Pano: Control Panel

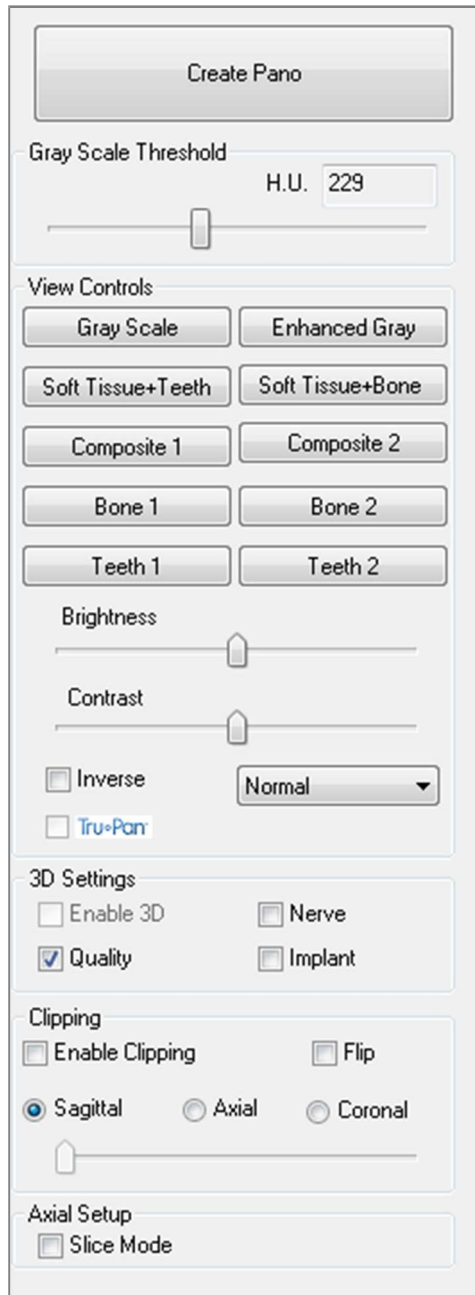

### Create Pano

- The lower-upper limit is adjusted by left-clicking on a green line and dragging with the mouse. It specifies the vertical dimension of the pano that is being created.
- The focal trough is adjusted by left-clicking on the yellow points and dragging with the mouse. The length, width, and shape of the focal trough are adjusted to specify what will appear in the pano.
- A preview is also shown in the rendering window.
- The Create Pano button should be pressed after the lower-upper limit and focal trough are first adjusted.

### Gray Scale Threshold

- This threshold sets the density limit in the pano.
- For noisy images, adjust the threshold so that the noise does not contribute to the pano.
- Threshold is usually set slightly below bone density.

### View Controls

- Pano can be rendered in multiple visualizations.
- Enhanced Gray sharpens Gray Scale rendering.
- By default, Enhanced Gray is selected.
- Brightness & Contrast: Can be adjusted to enhance your image.
- Inverse: Switches the background to white (switches coloring for Gray Scale Rendering).
- Sharpening Filter: Applies the selected sharpening filter from the drop-down menu to the 2D slice renderers.
- Tru-Pan™: This option enables the one-click volumetric pano that can be created from scans taken by an i-CAT© Cone Beam 3D system. (This setting is only displayed in the Control Panel when a Tru-Pan™ case is currently loaded.)

### 3D Settings

- Enable 3D: Select this feature to render the pano as a volumetric 3D image. The pano can be rotated, clipped, etc. like other volumes. (See Image Navigation, pg. 32.)
- Quality: Select this to give the highest level of detail for the generated pano.
- A traced nerve or placed implant can be toggled on/off with the “Nerve” and “Implant” boxes.

### Clipping

This option is only applicable when 3D Pano is available. Clipping hides some part of the image so that the internal structure can be visible.

### Axial Setup

The slice mode box lets you choose how the focal trough will be shown.

## Super Pano: Rendering Window

**Upper-Lower Limit:** The lower left box where the vertical parameter of the Super Pano is set. The green lines indicate the vertical limits. They can be dragged to set the desired upper and lower limit of the Super Pano. When “Slice Mode” is selected, the red line indicates where the focal trough plane is and can also be adjusted.

**Focal Trough:** The focal trough is adjusted in the lower middle box. Whatever is contained within it will appear in the Super Pano allowing the construction of a panoramic x-ray with minimal background noise. The yellow dots can be left-clicked and dragged to adjust the length, width and shape of the focal trough. The focal trough can be adjusted by dragging the focal trough control points, or a new trough can be created by clicking the trough icon on the toolbar.

**Preview:** A preview of the Super Pano will be displayed in the lower right box before creating it. This feature allows a Super Pano to be efficiently made with fewer or no adjustments needed afterward.

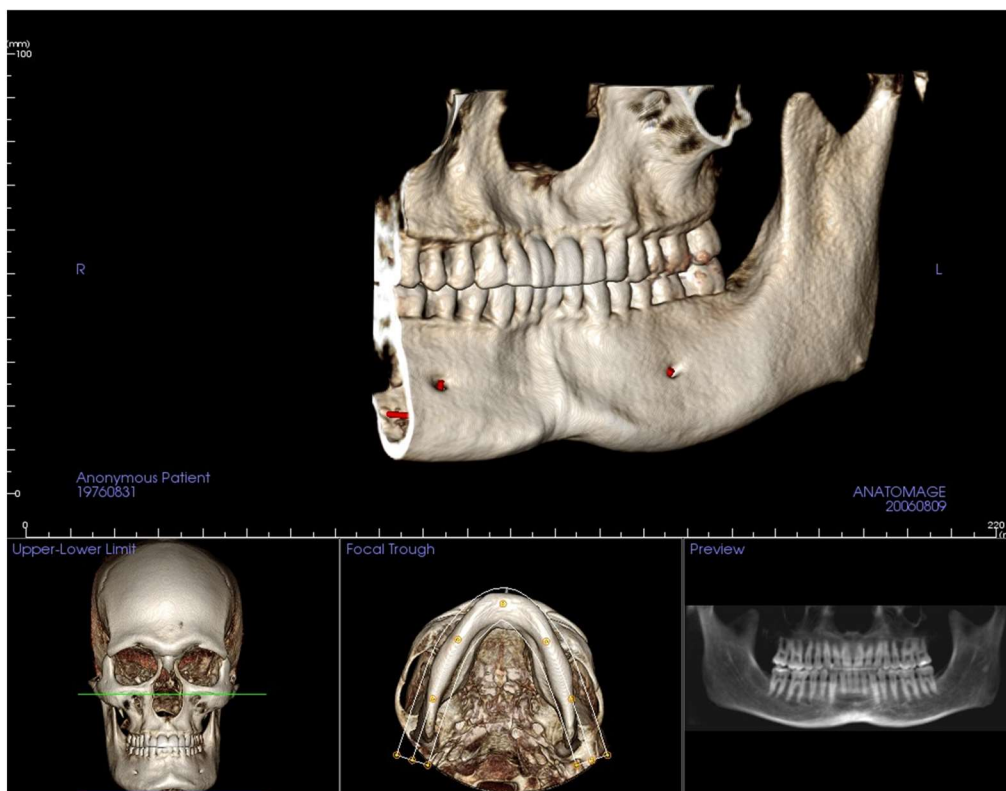

### How to make a good Pano?

- Make a U-shaped, narrow focal trough encompassing the arches by adjusting points on the focal trough.
- Adjust Gray Scale threshold to filter soft tissue, so that the image is not too dark or too light.
- Refer to Image Navigation (pg. 32) for information about controlling and adjusting these images.

# Super Ceph View Features

*The Super Ceph View Tab gives the ability to construct and view an enhanced version of a cephalometric radiograph, take measurements, and utilize several image enhancement features, all of which dramatically increases its diagnostic value.*

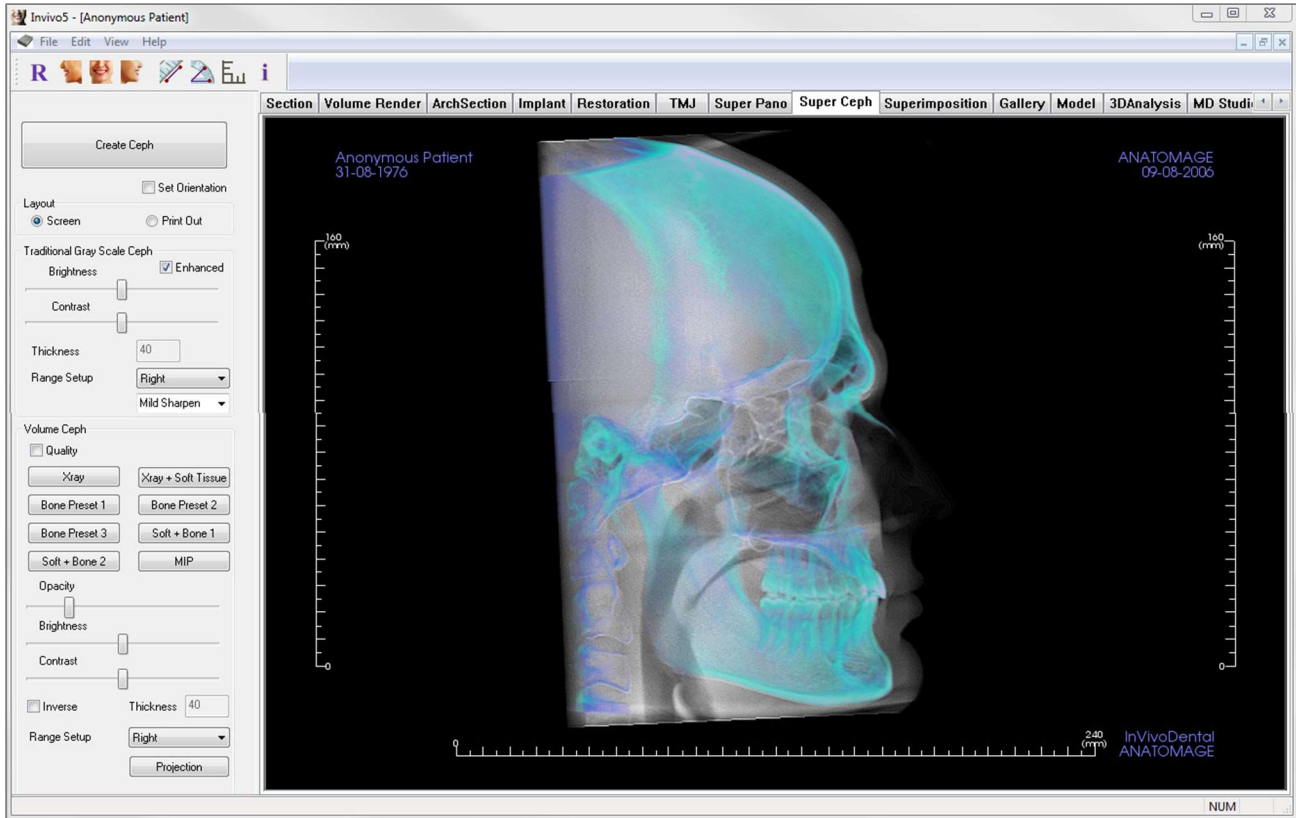

## Super Ceph: Toolbar

Shown below are the Toolbar and tools that are loaded with the Super Ceph View Tab:



Reset View: Resets the rendering window to the original view.



Left View: Automatically orients the volume so the patient is facing left sagittal.



Front View: Automatically orients the volume so that the patient is facing the front.



Right View: Automatically orients the volume so the patient is facing right sagittal.



Distance Measurement: After selecting this tool, click two points to mark the desired distance. A number in millimeters will automatically display.



Angle Measurement: After selecting this tool, click the first point, then click the vertex, then click the last point to create an angle. A number in degrees will automatically display.



Grid: Toggles between two different grid layouts for use in all of the section frames allowing quick assessment of measurements and spatial location.



Information Display: Displays or hides case information embedded in the data.



**Warning:** Any measurement that is incorrect can lead to surgical complications if diagnosis, treatment plans and/or actual treatment is based on the incorrect measurements. It is critical for the end user to learn how to perform measurements correctly and employ proper usage of all measurement tools. Measurement accuracy depends on the image data and the hardware scanner that generated the image data. The measurement cannot be more precise than the resolution of the image. Software reports the value based on user-picked points. Due to the nature of medical imaging, the boundary is not always well defined. The apparent boundary depends on the current brightness and contrast setting. The boundary may shift as the user makes adjustments to brightness and contrast. The user must understand the limitation of the measurement value before applying to the patient. If you notice any inconsistencies or software problems with measurements, or have further questions or concerns about using measurement tools correctly, please contact us at (408) 885-1474 or email us at [info@anatomage.com](mailto:info@anatomage.com)

## Super Ceph: Control Panel

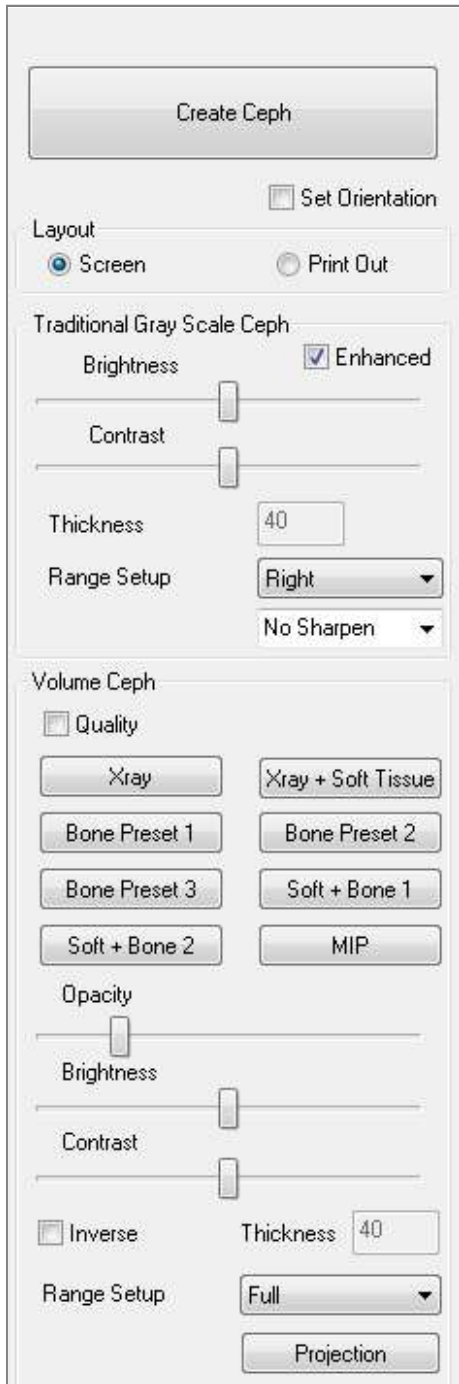

### Create Ceph

- The Create Ceph button should only be clicked after the orientation of the patient's volumetric image is adjusted in the rendering window.
- The "Set Orientation" box will reset the orientation if a ceph was created incorrectly. Once the image is orientated correctly, press the Create Ceph button again.

### Layout:

- "Screen" layout is optimized for viewing the image on the computer screen. "Print Out" layout is optimized for printing the image on paper. With Print Out layout, what you see on screen will be what you get on the paper in life-size. First, capture to Gallery, then print from Gallery to ensure the image is life size.

### Traditional Gray Scale Ceph

- Brightness and Contrast can be adjusted to enhance your image.
- The "Enhanced" box can be left-clicked on or off to sharpen and enhance the quality of the image.
- Range Setup allows you to select which side of the patient's head the ceph will be created from. Thickness allows you to control how wide the range is.
- When you change the Range Setup, you must recreate the ceph image using the Create Ceph button.
- Sharpening Filter: Applies the selected sharpening filter from the drop-down menu to the 2D slice renderers.

### Volume Ceph

- Increase the Opacity slider to superimpose the volume rendering onto the generated ceph.
- Various enhanced views of the ceph can be added; each has different advantages:
  - Bone highlights hard-tissue landmarks.
  - Soft+Bone emphasizes the soft-tissue on the ceph
  - Opacity, brightness, and contrast can all be adjusted for image enhancement.

- Inverse switches the background to white. (Gray Scale coloring switches black/white.)
- Range Setup allows you to select which side of the patient's head the ceph will be created from.
- Projection allows you to switch from parallel views of the cephalometric images to perspective views which resemble the magnification found in traditional cephalometric radiographs.



## Super Ceph: Rendering Window

This window is where the volumetric image of the patient is orientated to create a ceph and where the ceph will be viewed after creating it.

Before clicking on the Create Ceph button in the Control Panel, the patient's volumetric image must be correctly orientated. The easiest way to do this is to line up the left and right angles of the mandible. If the ceph is created with an improper orientation, it can be adjusted using the "Set Orientation" box in the Control Panel.

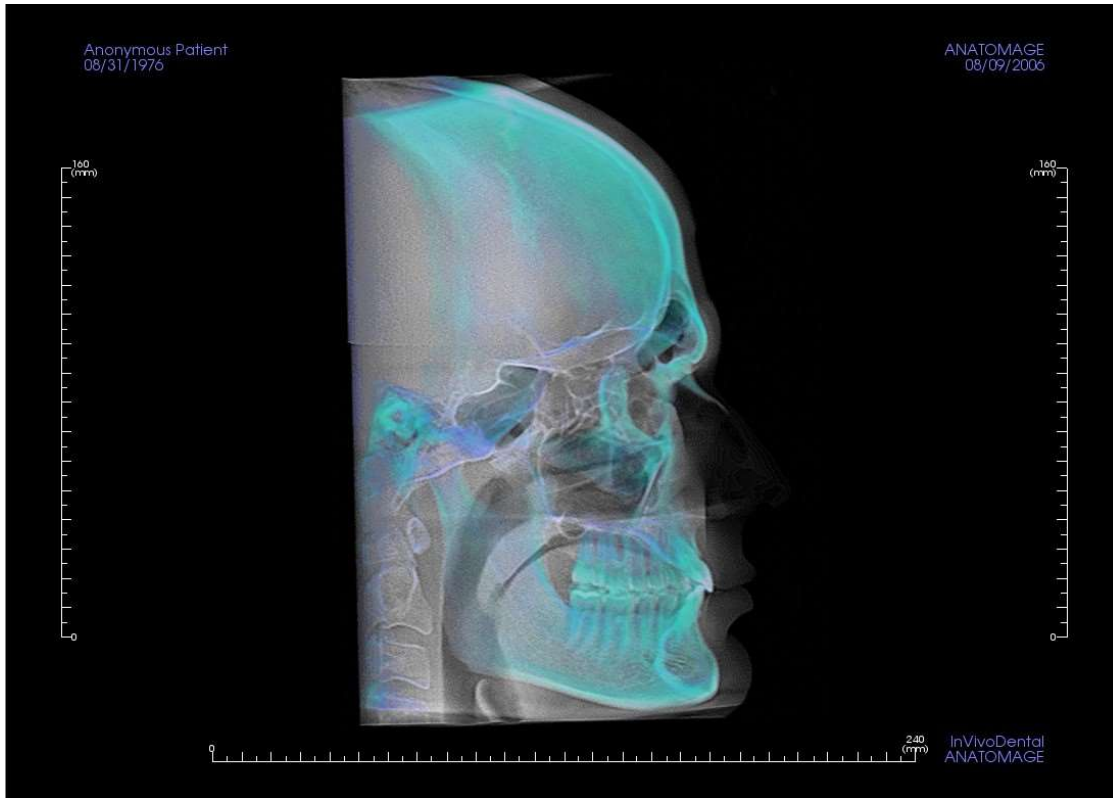

Please refer to [Image Navigation \(pg. 32\)](#) for information about controlling and adjusting these images.

# Superimposition View Features

*In the Superimposition View Tab, you have the ability to open two different scans at once, view them side by side, and superimpose them. This is especially useful for assessing pre- and post-treatment scans.*

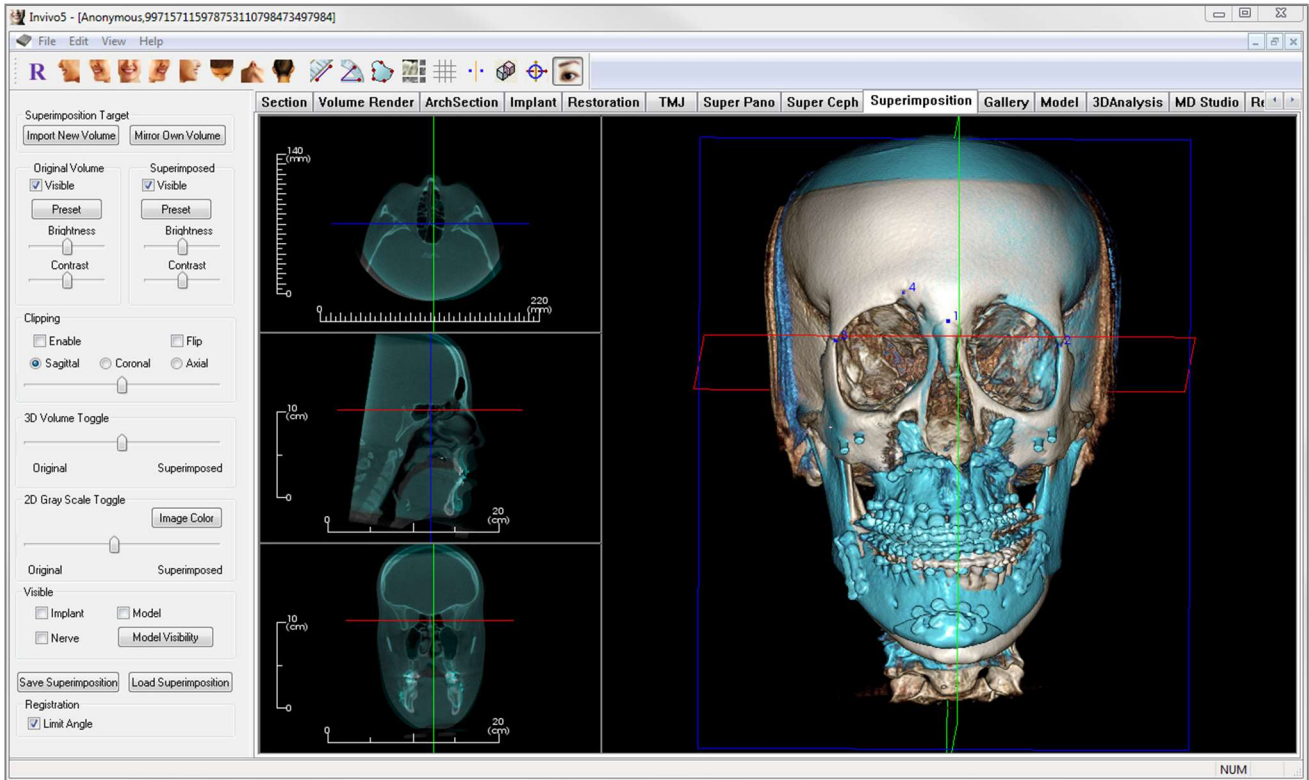

## Superimposition: Toolbar

Shown below are the Toolbar and tools that are loaded with the Superimposition View Tab:



Reset View: Resets the rendering window to the original view size.



Left View: Automatically orients the volume so the patient is facing left sagittal.



Left  $\frac{3}{4}$  View: Automatically orients the volume so the patient is facing 45° left sagittal.



Front View: Automatically orients the volume so the patient is facing the front.



Right  $\frac{3}{4}$  View: Automatically orients the volume so the patient is facing 45° right sagittal.



Right View: Automatically orients the volume so the patient is facing right sagittal.



Top View: Automatically orients the volume so you are oriented above the patient.



Bottom View: Automatically orients the volume so you are oriented below the patient.



Back View: Automatically orients the volume to the posterior view.



Distance Measurement: Select this option and mark two points on the volume and distance will appear. Clicking on the point and moving the cursor can modify points. Click on the measurement and press the “delete” key to delete it. Control Panel features in Volume Render Tab allow the values to be projected to 2D, hidden, or exported to a report.



Angle Measurement: Select this option and mark three points on the volume and the angle between them will appear. Clicking on their control points and moving the cursor can modify measurements. Click on the measurement and press the “delete” key to delete it. Control Panel features in Volume Render Tab allow the values to be projected to 2D, hidden, or exported to a report.



Area Measurement: After selecting this tool, click multiple points along the boundary of the desired area. Double-click or right-click to end the measurement. A number in millimeters squared will automatically be displayed. Control Panel features in Volume Render Tab allow the values to be projected to 2D, hidden, or exported to a report.



Change Layout: Toggles the rendering window layout.



Toggle Grid: Toggles between two different grid layouts for use in the upper two section frames allowing quick assessment of measurements and spatial location.



Registration: This icon is used to register the original volume to the second volume. Four or more anatomical points are chosen from each scan to properly align both scans at common, stable landmarks.



Volume Registration: This icon is used to open the Volume Registration interface for automatic superimposed volume registration. Users will define a VOI (Volume of Interest) Box as a reference

for automated superimposition.



Adjust: This icon is used to make adjustments to better align the two volumes that are superimposed.



3D Cursor: Toggles on/off the cursor lines in the 3D volume rendering.



Warning: Any measurement that is incorrect can lead to surgical complications if diagnosis, treatment plans and/or actual treatment is based on the incorrect measurements. It is critical for the end user to learn how to perform measurements correctly and employ proper usage of all measurement tools. Measurement accuracy depends on the image data and the hardware scanner that generated the image data. The measurement cannot be more precise than the resolution of the image. Software reports the value based on user-picked points. Due to the nature of medical imaging, the boundary is not always well defined. The apparent boundary depends on the current brightness and contrast setting. The boundary may shift as the user makes adjustments to brightness and contrast. The user must understand the limitation of the measurement value before applying to the patient. If you notice any inconsistencies or software problems with measurements, or have further questions or concerns about using measurement tools correctly, please contact us at (408) 885-1474 or email us at [info@anatomage.com](mailto:info@anatomage.com)

## Superimposition: Control Panel

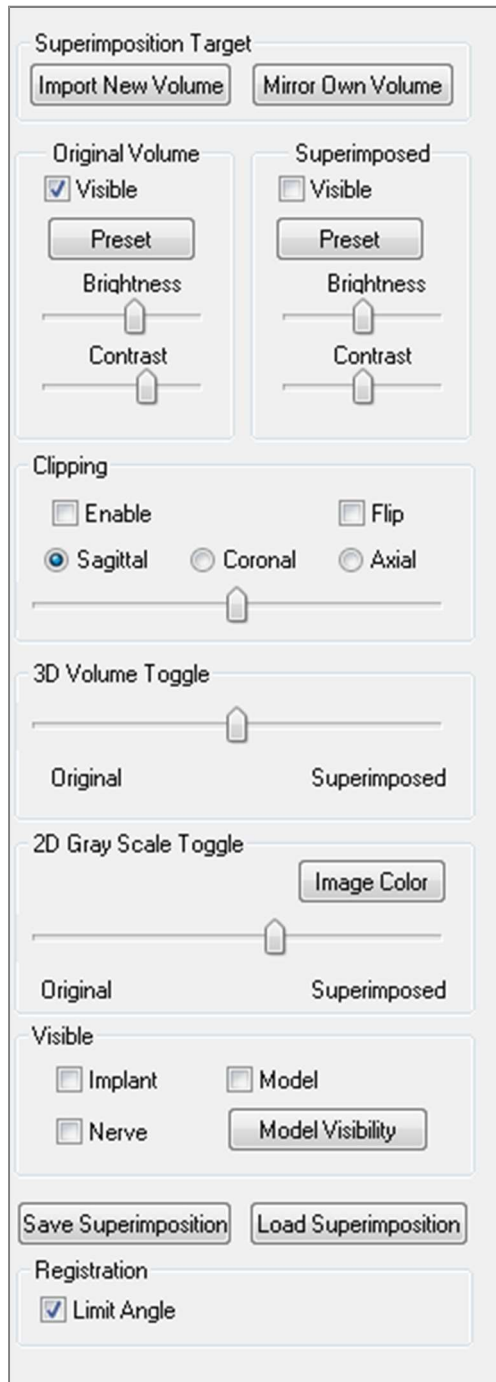

### Superimposition Target:

- Select Import New Volume to import a second volume. Superimpose either an Invivo file (.inv) or DICOM (.dcm) scan set.
- Volumes will be registered to each other by selecting four or more landmarks on each volume using the Registration tool.
- Select Mirror Own Volume to mirror the patient's anatomy to check for asymmetries.

### Original Volume and Superimposed:

- Visible turns on/off either volume independent of each other.
- Preset allows you to choose different visualization presets for the volume.
- Preset can also be selected independent of each other.
- The Brightness and Contrast in the volume renderings can be adjusted independently and improve the image.

### Clipping:

- Select “Enable” to slice the image along predefined anatomical planes (sagittal, coronal, axial).
- Select “Flip” to switch the view to the opposite side.
- Control Clipping with the scroll mouse or slider.

### 3D Volume Toggle:

This slider allows you switch between the original volume and superimposed volume. Set the slider in the middle to visualize both volumes in equal opacity. Set the slider to one side to visualize only one image.

### 2D Gray Scale Toggle:

This slider allows you switch between the original gray scale slice and superimposed one. Set the slider in the middle to visualize both volumes in equal opacity. Set the slider to one side to visualize only one image. The Image Color button allows you to change the slice color.

### Visible:

- Selectively control the visibility of the implants, nerves, and models.
- In Model Visibility, you can hide/show individual models in the rendering window.

### Save Superimposition:

- This allows you to save the settings of the superimposition into an external file.
- In the dialog that appears, choose where and what filename to save.
- Invivo will save two files: .vdata and .odata

- .vdata: stores the registration points and superimposed volume information
- .odata: stores the original scan's volume orientation information

#### Load Superimposition:

- This allows you to restore saved superimposition.
- Select Load Superimposition and choose the correct .vdata file.
- The superimposition file will be reloaded with the saved volume.

#### Registration:

“Limit Angle” will set limitations within the software during its registration calculations. If you are experiencing inaccurate superimpositions after registering your points due to volume inversions, selecting Limit Angle may resolve some of these issues. It is recommended that you attempt to use different or additional registration points if this does not resolve the volume inversions.

## Superimposition: How to Superimpose Two Volumes

Invivo provides easy-to-use tools for superimposition. Although they are easy to use, superimposition is a technique-sensitive procedure with the most critical step being the registration of the new scan via the selection of stable landmarks in both scans. The proceeding sections discuss how to superimpose two scans step by step.

**Step 1: Open First File.** Open the file that you want to start with. You do not have to open them in any order, but starting with the pre-treatment scan may be recommended for sake of organization. See DICOM and Invivo File Loading (pg. 24) section if you are unsure of how to open an Invivo file.

**Step 2: Import Volume.** Go to the Superimposition Tab and from the Control Panel, click on the Import New Volume option to select the second file to open. The File Manager will appear allowing you to open either a DICOM file or an Invivo file.

**Step 3: Press the Registration icon.** It can be found in the Superimposition Toolbar.



**Step 4: Registering the Two Scans to Each Other.** In order to superimpose the scans as correctly and precisely as possible, strict attention must be placed in selecting at least four matching and stable landmarks in both scans.

- To select landmarks on each volume:
  - Press down on the center scroll-wheel of the mouse.
  - Or, position the mouse over the landmark and press the space bar on the keyboard.
- Select the first stable landmark on one scan using either method above.
- Select the matching stable landmark on the other scan using either method above.
  - Each point shows up as either a blue or red dot.
  - Points are numbered for easy reference.
- The volume can be rotated using the left-mouse button as before.
- The volume can be clipped by selecting Clipping: “Enable” in the Control Panel.
- The volume rendering presets can be adjusted using the Preset button.
- Use caution in setting your Brightness and Contrast settings.
  - Be sure the Brightness and Contrast settings for the original and imported volumes are similar.
  - Be sure to use the similar Preset settings when registering points.

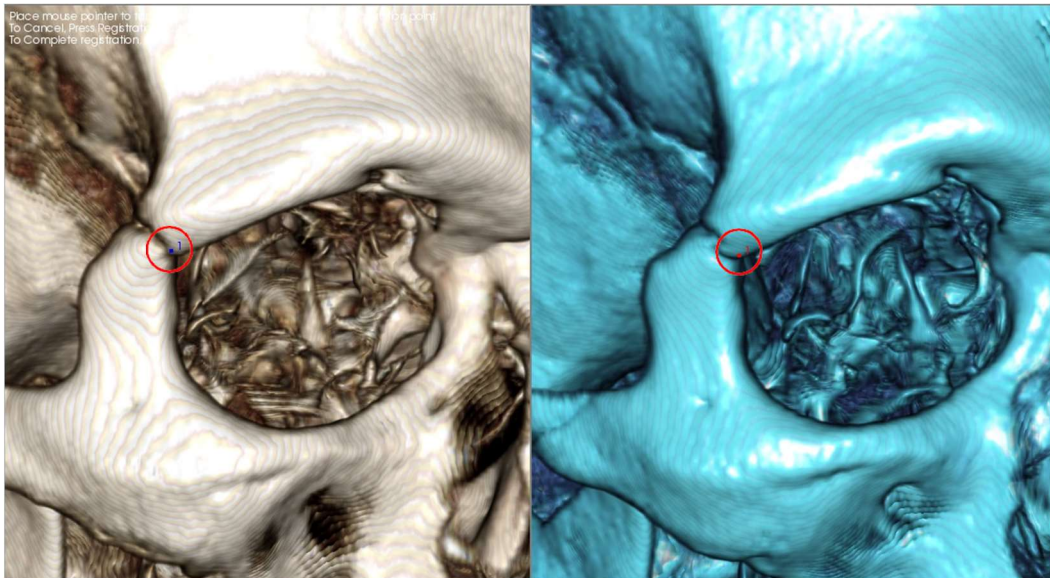

*The image above shows a registration point (Registration Point 1) located on the anterior point of the right zygomaticofrontal suture. The point has been added to both the original scan (white, left) and the new scan (blue, right).*

Step 5: Save Points and Finish Registration. Once all points are plotted one by one, click the right-mouse button to register the two scans. It is recommended you practice by opening the same scan twice before trying to superimpose two different scans. You can see how precise the superimposition is by how much the two registered scans overlap using the 2D and 3D toggle tools.

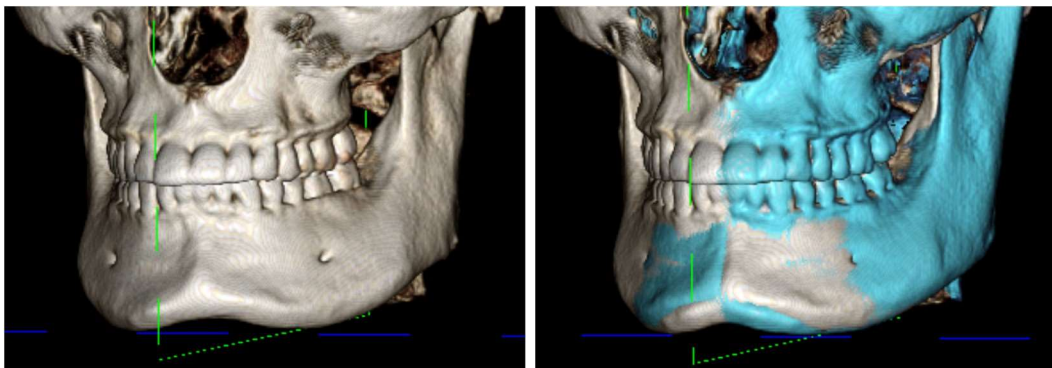

(a)

(b)

*(a) The above image on the left is of two identical data sets that are registered to each other precisely. Notice there are no overlapping areas of different colors.*

*(b) The image on the right is of two volumes not registered precisely. Notice the blue and white skeletal boundaries do not line up, and the presence of double images.*



## Superimposition: Using Superimposition Aligner for Fine Adjustments

After finishing the landmark registration, you can use the other tools provided in the Superimposition Toolbar to make final adjustments to your superimposition.



To make the cross sections bigger, use the Change Layout icon from the Toolbar



To move the volume manually, use the Adjust icon from the Toolbar to display the move widget on the superimposed volume

The above tools are available for use prior to using the Landmark Selector; however, it is strongly recommended that you first use the Registration tool before using the Adjust tool.

Check the cross sections for accuracy by adjusting the Layout (Change Layout icon) and the 2D Gray Scale Toggle slider. The superimposition is shown in 3D as well as in the cross sections. Make the necessary adjustments.

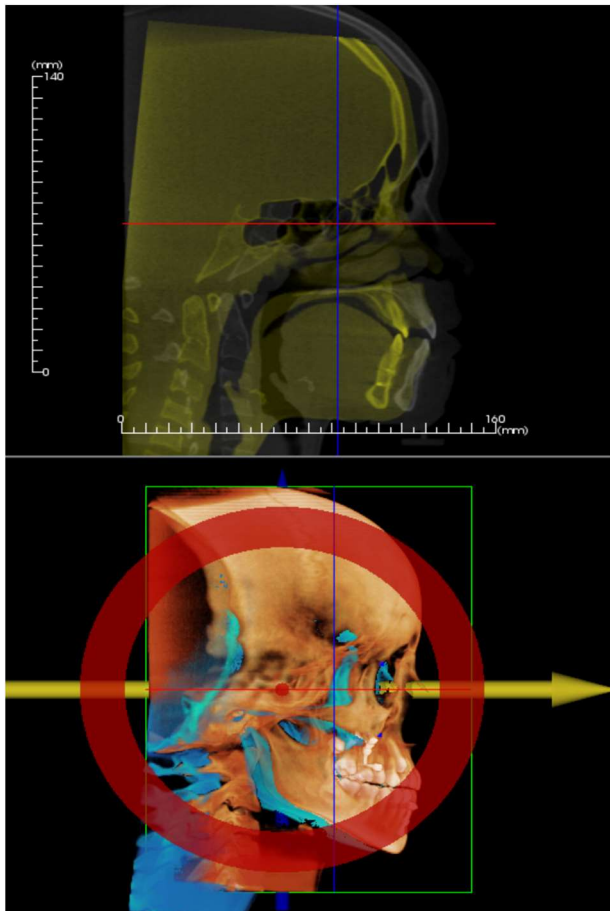

For example, notice in the sagittal section shown to the left that the superimposed volume is not totally overlapped. Using the Adjust tool, move the volume in the anterior-posterior direction until the sections align by clicking on the yellow arrow in the move widget and dragging it forwards or backwards.

One should go through each anatomical plane to check for precision. The cranial base should match up perfectly because it is stable; however, the vertebrae will usually be off because the patient's head is always tilted somewhat differently in each scan.

## Superimposition: Using Volume Registration for Fine Adjustments

After finishing the landmark registration, you can use the other tools provided in the Superimposition Toolbar to make final adjustments to your superimposition.



To make the cross sections bigger, use the Change Layout icon from the Toolbar



To fine-tune the registered volumes, use the Volume Registration icon from the Toolbar to open the Volume Registration interface

The above tools are available for use prior to using the Landmark Selector; however, it is strongly recommended that you first use the Registration tool before using the Volume Registration tool.

Select the Volume Registration icon in the toolbar to open the Volume Registration interface.

Left-click on any of the 2D cross sections to place the center of the VOI (Volume of Interest) Box. The VOI box can be moved at any time by clicking another location in one of the 2D cross sections.

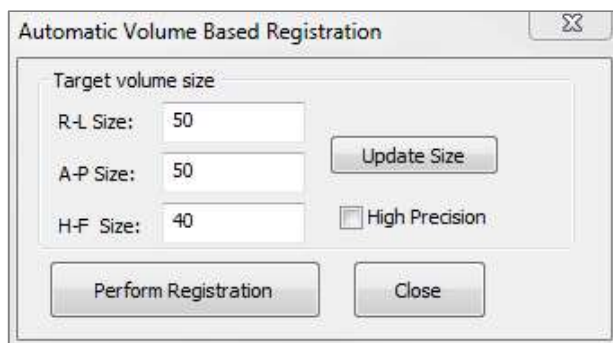

Target Volume Size:

- R-L Size: defines the lateral width (mm) of the VOI Box.
- A-P Size: defines the anterior-posterior width (mm) of the VOI Box.
- H-F Size: defines the inferior-superior height (mm) of the VOI Box.
- Press Update Size to show the updated VOI Box size in the rendering window.

Select Perform Registration to run the automatic registration process for the VOI Box selected. The process time is based on your computer's hardware components; however, in general, the larger the VOI Box, the more time is required to complete the automatic registration.

The following images show the VOI Box applied near the cranial base of a pre- and post-surgery superimposed scan (top image) and the results of the automatic registration process (bottom image). Notice that the two cranial base profiles line up exactly following the automatic registration process. The VOI Box used is the default  $(x, y, z) = 50\text{mm} \times 50\text{mm} \times 40\text{mm}$ .

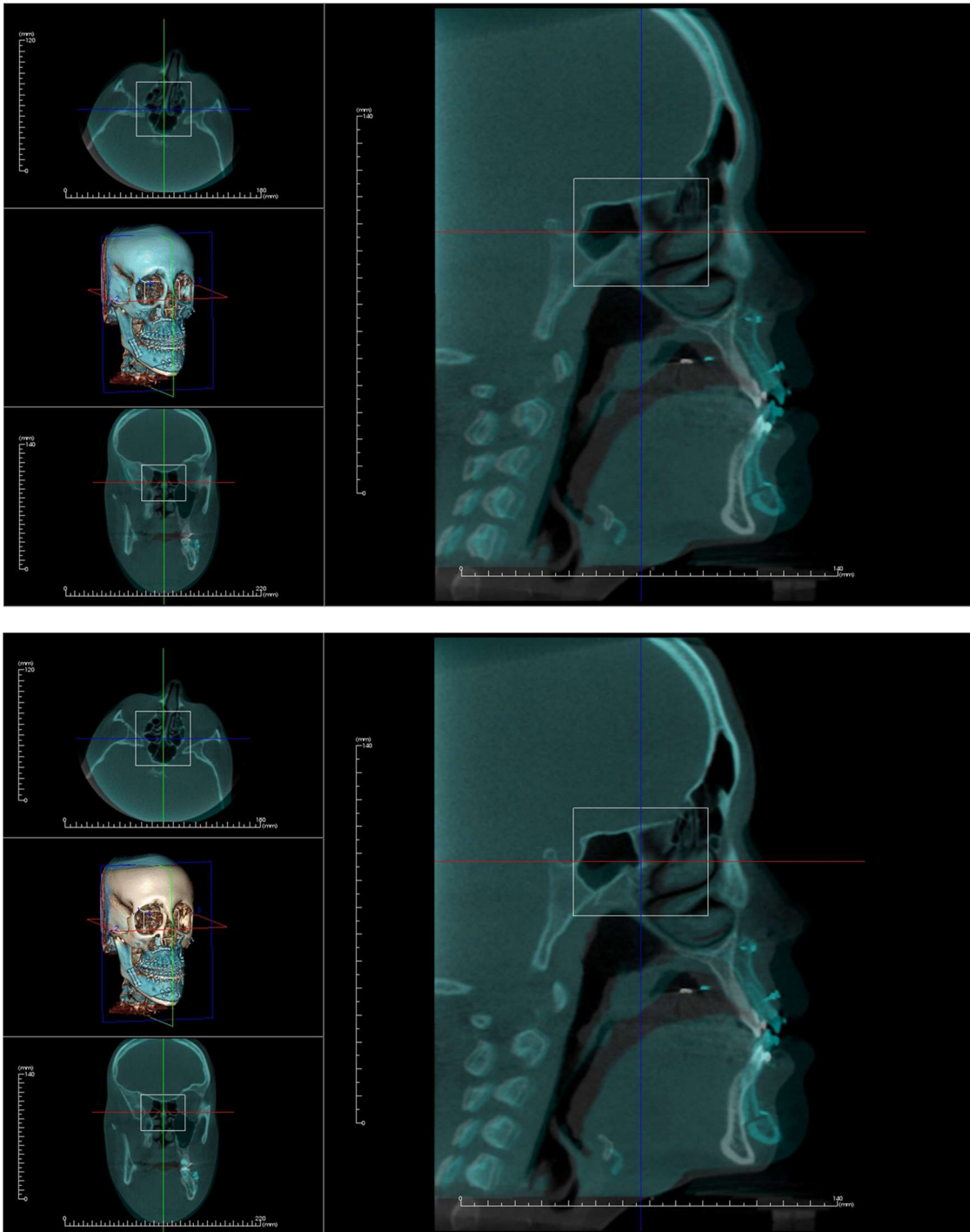

## Superimposition: Difference Between .vdata Files and .odata Files

After you have successfully registered a different scan to your original volume data, Invivo allows you to save the superimposition data using the Save Superimposition button. This section looks to further define the difference between the output files (.vdata and .odata) and how to use them.

### .vdata

Information stored in the .vdata file includes the registration points and the path for finding your superimposed scan data. When you re-open your original scan, in the Superimposition Tab, press the Load Superimposition button and load the desired .vdata file. This will allow you to look at the superimposed image without having to re-register your landmarks.

### .odata

Information stored in the .odata file includes the orientation information of your original scan data (not your superimposed scan). With this information, you can set specific orientations for other cases as well.

To import a new orientation, go to File in the Menu Bar and select “Import Orientation.” Choose your desired .odata file, and your case will automatically reorient itself.

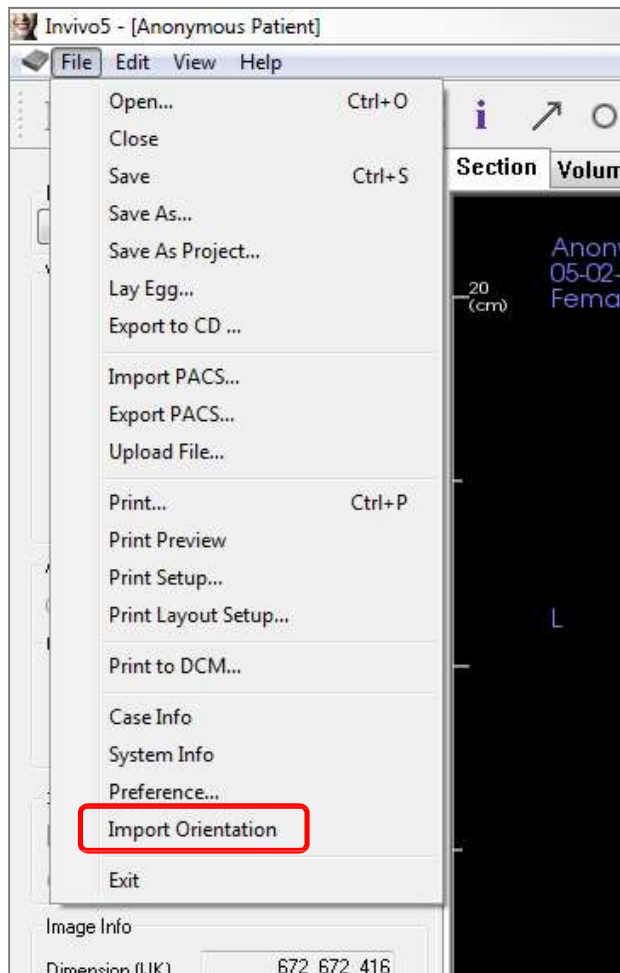

# Gallery View Features

*In the Gallery View Tab you can retrieve images that have been captured. Additionally, images can be imported into Invivo or exported to the location of your choice. Comments or notes can be added to describe images that have been captured.*

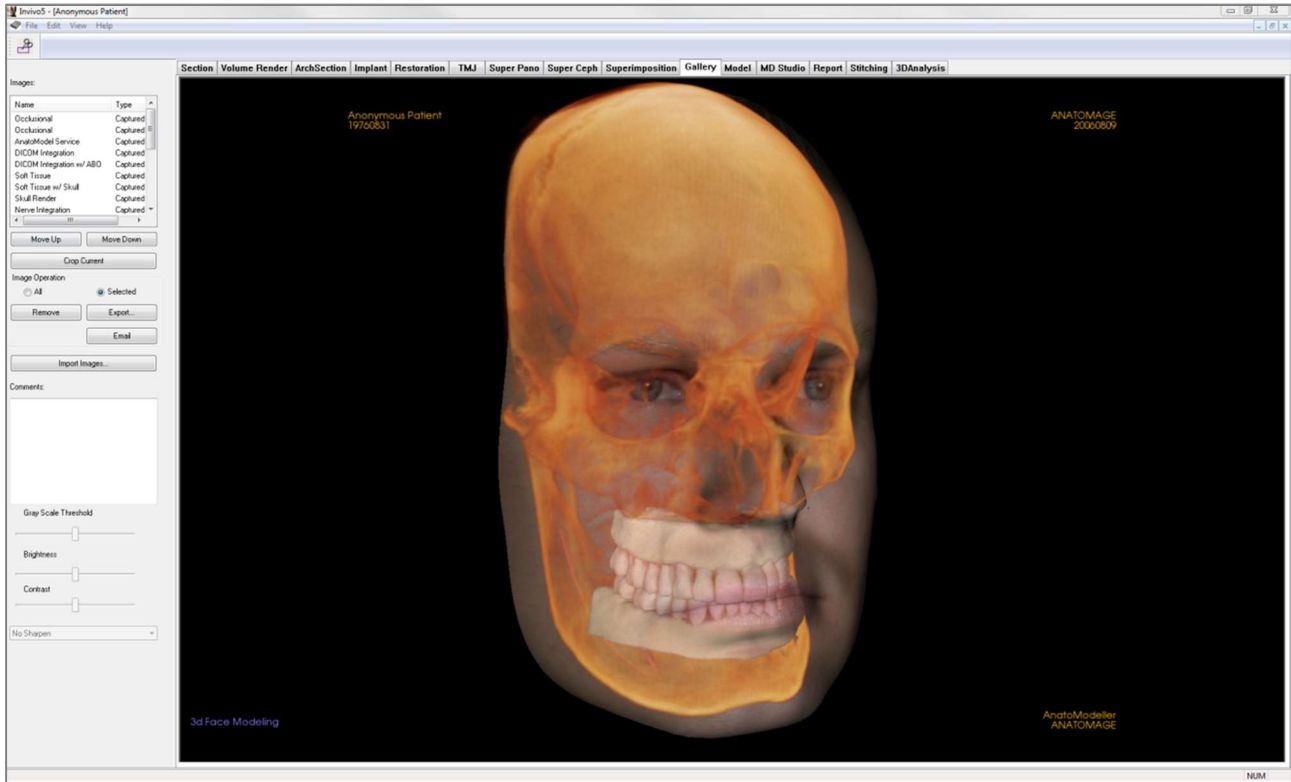

## Gallery: Toolbar

Shown below are the Toolbar and tools that are loaded with the Gallery View Tab:



Crop Image: Allows you to crop and save the image that was captured.

## Gallery: Control Panel

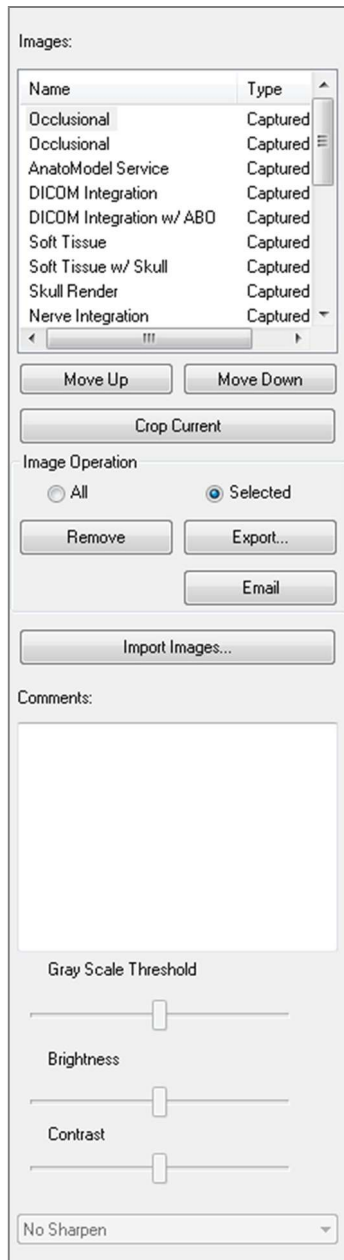

Images: Gives a list of all captured images.

- Each of these images has a “Name” and “Type” which can be renamed by double-clicking on the text.
- Move Up/Down: Moves the selected image up or down on the list.
- Crop Current: Allows you to crop the currently selected image within Invivo.

Image Operation

- All/Selected: Applies operation to all or a subset of the images from the list.
- Remove: Removes images from the Gallery.
- Export: Allows you to export the images in the Image List to a path specified in the dialog box that opens. Files can be saved as one of the following formats: .jpg, .bmp, or .png.
- Email: Captures all images to your email ready to send. This requires having a mailer client set up.

Import Images:

- Select to import images (.jpg, .bmp, .png) from an external source into the Gallery Tab.
- Using this, you can import patient photographs into the Invivo software for storage within the Invivo file once saved.

Comments:

- Text box displays comments about the image displayed in the rendering window.
- Add or change comments by editing the text in the Comments Box.

2D Image Options:

- Controls settings for 2D images. See more information in Gallery: 2D Image Options.

## Gallery: Rendering Window

This window allows the viewing of captured and imported images. The Gallery is particularly useful for creating a workup of a particular case. Remember that the Gallery's images will only be saved if you re-save the whole file; otherwise, any captured images will be lost.

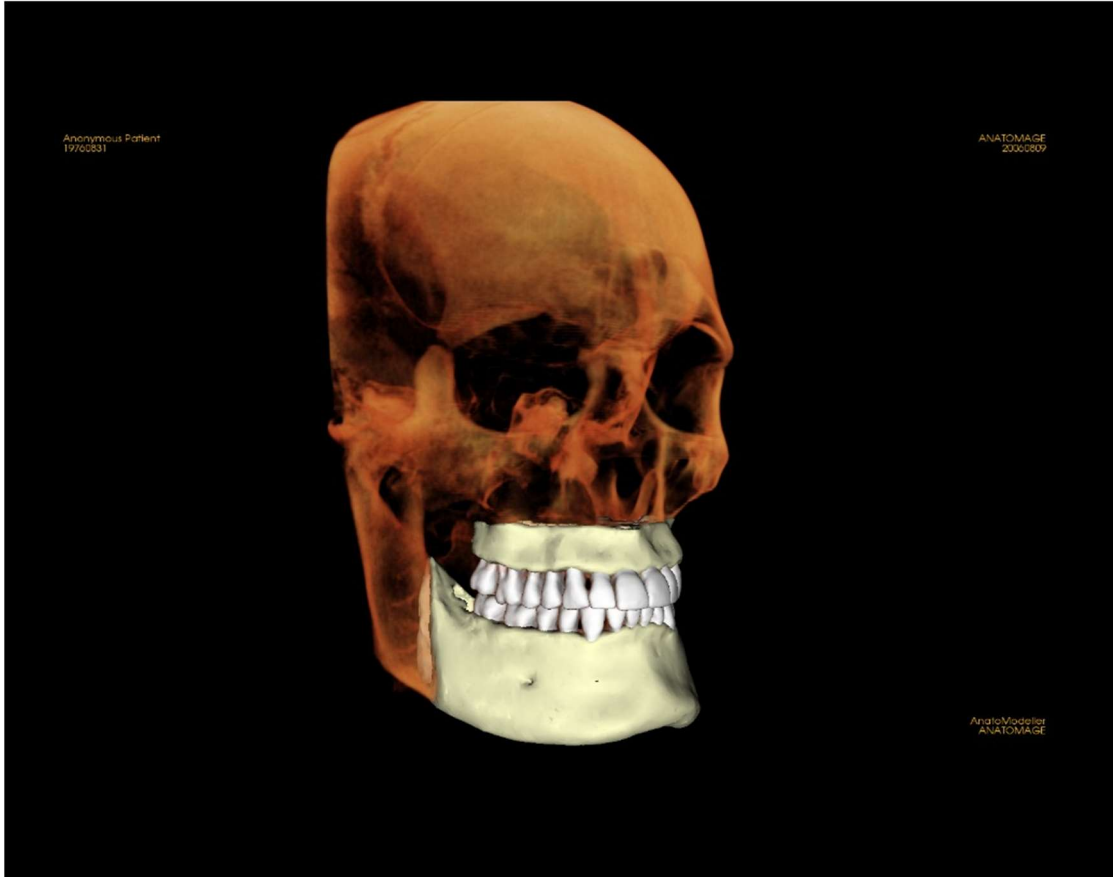

Please refer to [Image Navigation \(pg. 32\)](#) for information about controlling and adjusting these images.

## Gallery: Adding Images to the Gallery

Capture any single image to the Gallery. A single image within any view can be captured without including the other parts of the rendering window. When the Capture to Gallery function is used, a dialog will appear on the screen providing the user with options regarding which parts of the rendering window to capture.

The options provided by each dialog will vary according to which Invivo tab is currently displayed; the following example is the dialog that appears within the ArchSection Tab:

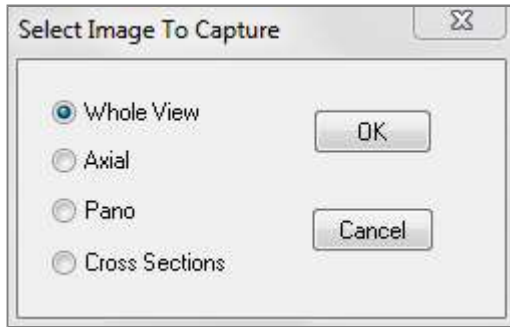

Ex. ArchSection Capture to Gallery

Capture to Gallery Dialog:

- Whole View – Captures a screenshot of the rendering window
- Axial – Captures the axial slice view and no other parts of the rendering window
- Pano – Captures the pano view and no other parts of the rendering window
- Cross Sections – Captures a series of slices that are within the rendering window

Options within each Select Image to Capture Dialog:

Note: Some options will appear gray (disabled) in the Select Image to Capture dialog. The choices available are determined by the specific layout as well as the view tab.

Section	Whole View Axial, Coronal, Sagittal Slices Cross (Displays Custom Cross Section or 3D Volume)
Volume Rendering	No Dialog
ArchSection	Whole View Axial Pano Cross Sections
Implant	Whole View Main Volume Axial Cross Density Para Arch Pano Arch Volume Front Volume
TMJ	Whole View Axial Left Pano Left Cross Section Right Pano Right Cross Sections



Super Pano	Whole View Pano Front Volume	Axial Preview Pano
Super Ceph	No Dialog	
Superimposition	Whole View Main Volume Axial	Coronal Sagittal Imposed Volume
Model	Normal Layout  Occlusal Layout  Composite Layout	No Dialog  Whole View Lower Occlusional Upper Occlusional  Whole View Composite 1-9

Capture to Gallery Dialog:

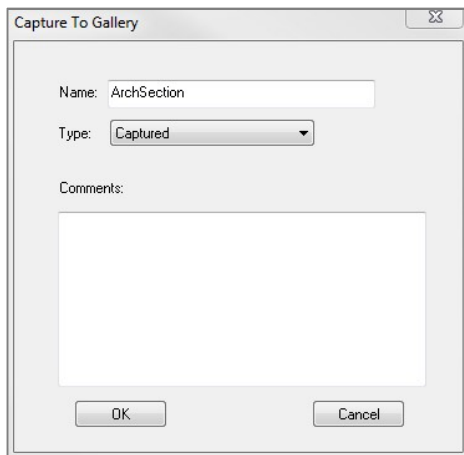

Name: Image label

*Note: Image name must be unique from any other captured image in the Gallery and must not contain any special characters.*

Type: Image type – can be set from the drop-down to “Captured” or “Photo.”

Comments: Additional comments about the image can be added in this section.

## Gallery: 2D Image Options

The Gallery Tab is compatible with 2D DICOM images and has several features that allow it to handle this image format better.

### Opening 2D DICOM

When instructed to open a 2D DICOM image, Invivo will automatically enter a mode that disables 3D functionality. Only the Gallery Tab will be available within the software and the DICOM will appear as a Gallery image.

If a 2D DICOM is associated with a 3D volume as a scout image, opening the volume will automatically import that scout image into the Gallery Tab.

### Grayscale Image Options

For grayscale images in the Gallery, the user has the option to adjust several settings such as Gray Scale Threshold, Brightness, Contrast, and Sharpening.

The updates to these images are saved and always reflect the updated settings when the image is selected in the Gallery and also after it has been saved/exported and then opened/imported back into Invivo.

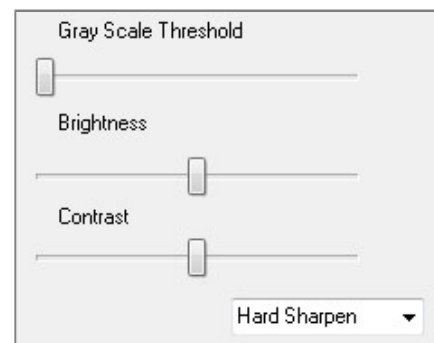

### Export to DCM/JPG/PNG/TIF/BMP

An image in the Gallery can be exported into any of the above formats when using the Export... button. When saving individual Gallery images to file, the following image formats will be available (JPG, PNG, BMP).

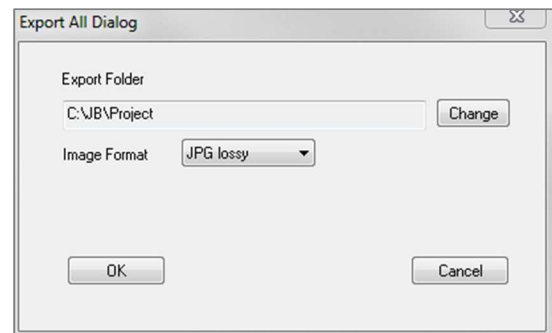

# Model View Features

The Model View Tab allows the user to see the patient's AnatoModel or 3D photograph and create surgical or orthodontic simulations, as well as 3D soft tissue predictions. An AnatoModel is a 3D digital study model that is made by Anatomage on a case-by-case service. The DICOM data of the patient is sent to Anatomage where it is modeled to create the most advanced digital study model available. AnatoModels contain anatomy such as roots, developing teeth, impactions, alveolar bone, and more, while other models merely show the crowns of teeth. The 3D photograph service that Anatomage offers is also viewed here. Anatomage developed the technology to combine a frontal photo of the patient and the CT scan to create a 3D model that overlays the scan data.

Any nerve tracing, implant planning, or superimposition that has been done will also be visible in the Model Tab. Each item can be independently turned on/off to see how all these systems come together with the scan data.

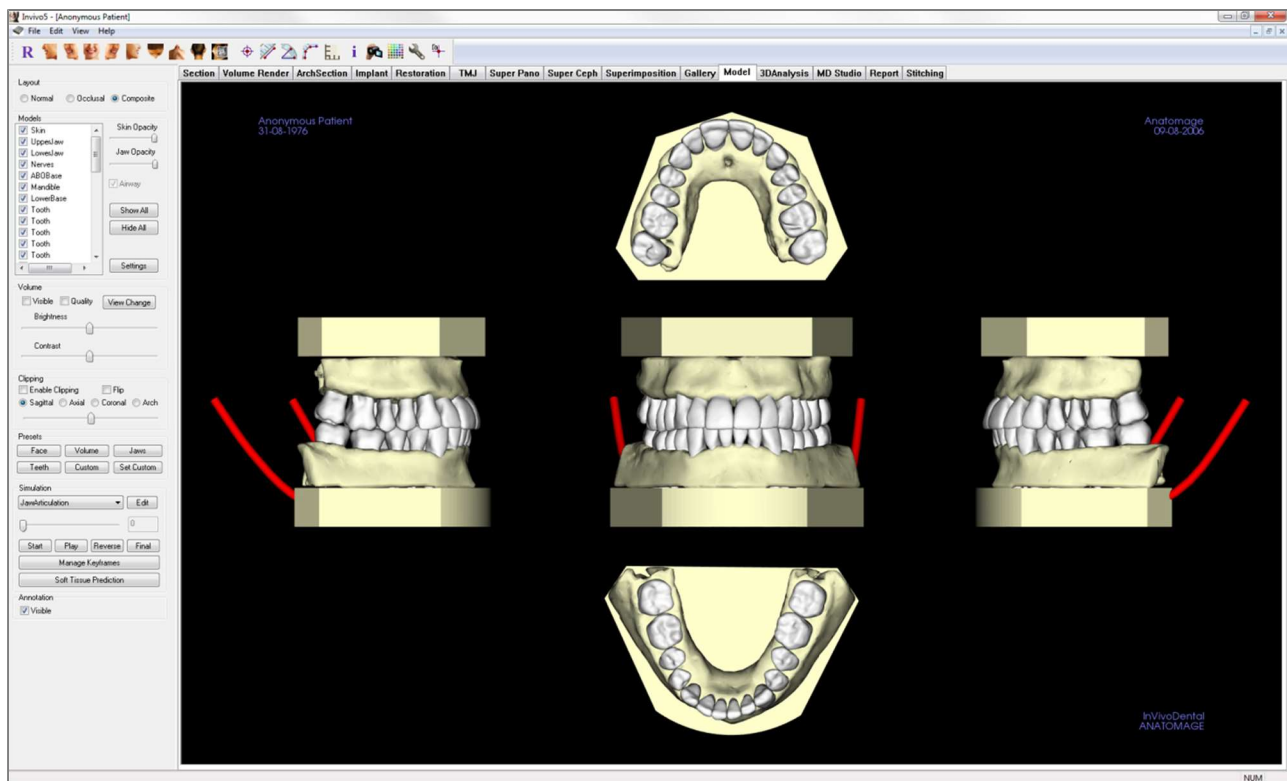

For additional information about the AnatoModel service, please contact Anatomage at (408) 885-1474 or email us at [info@anatomage.com](mailto:info@anatomage.com).

## Model: Toolbar

Shown below are the Toolbar and tools that are loaded with the Model View Tab:

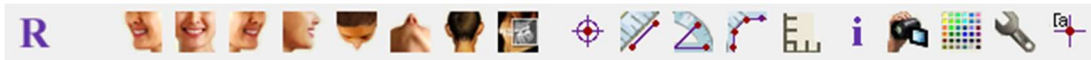

Reset View: Resets the rendering window to the original view size.



Left View: Automatically orients the volume so the patient is facing left sagittal.



Left  $\frac{3}{4}$  View: Automatically orients the volume so the patient is facing 45° left sagittal.



Frontal View: Automatically orients the volume so the patient is facing the front.



Right  $\frac{3}{4}$  View: Automatically orients the volume so the patient is facing 45° right sagittal.



Right View: Automatically orients the volume so the patient is facing right sagittal.



Top View: Automatically orients the volume so you are oriented above the patient.



Bottom View: Automatically orients the volume so you are oriented below the patient.



Back View: Automatically orients the volume to the posterior view.



Quick Slice: Once activated, clicking on a point on the volume will open a 2D zoom window in that location. The zoom window can be scrolled through using the mouse wheel.



Marker: When selected you may mark a point on the volume and X,Y,Z coordinates (transverse, sagittal, vertical) will appear. Clicking on the point and moving the cursor can modify points. Click on the point and press the “delete” key to delete it.



Distance Measurement: Select this option and mark two points on the volume and distance will appear. Clicking on the point and moving the cursor can modify points. Click on the measurement and press the “delete” key to delete it. Control Panel in Volume Render Tab features allow the values to be projected to 2D, hidden, or exported to a report.



Angle Measurement: Select this option and mark three points on the volume and the angle between them will appear. Clicking on their control points and moving the cursor can modify measurements. Click on the measurement and press the “delete” key to delete it. Control Panel features in Volume Render Tab allow the values to be projected to 2D, hidden, or exported to a report.



Polygonal Measurement: When selected you may mark unlimited number of points on the volume and the total between the first point and the last point will appear. Right-click your mouse to indicate that you have marked your last point. Clicking on the point and moving the cursor can modify points. Click on the measurement and press the “delete” key to delete it. Control Panel features allow the values to be projected to 2D, hidden, or exported to a report.



Toggle Grid: Toggles between four different grid layouts for simple assessment of size, measurement, and spatial location.



Information Display: Displays or hides case information embedded in the data.



View Sequence: Allows for the creation of custom camera sequences for movie capturing. Refer to the Volume Render Tab: View Sequence (pg. 52) section for additional information and description.



Background: Allows for the background color to be changed.



Setup View: Allows option to view either parallel or perspective views in 3D. You can change the annotation layout options under the Setup View.



Comment Marker: Pick a point in the volume and enter comments. Enter the text you would like to appear in the Insert Comment window and press OK.



Warning: Any measurement that is incorrect can lead to surgical complications if diagnosis, treatment plans and/or actual treatment is based on the incorrect measurements. It is critical for the end user to learn how to perform measurements correctly and employ proper usage of all measurement tools. Measurement accuracy depends on the image data and the hardware scanner that generated the image data. The measurement cannot be more precise than the resolution of the image. Software reports the value based on user-picked points. Due to the nature of medical imaging, the boundary is not always well defined. The apparent boundary depends on the current brightness and contrast setting. The boundary may shift as the user makes adjustments to brightness and contrast. The user must understand the limitation of the measurement value before applying to the patient. If you notice any inconsistencies or software problems with measurements, or have further questions or concerns about using measurement tools correctly, please contact us at (408) 885-1474 or email us at [info@anatomage.com](mailto:info@anatomage.com)

## Model: Control Panel

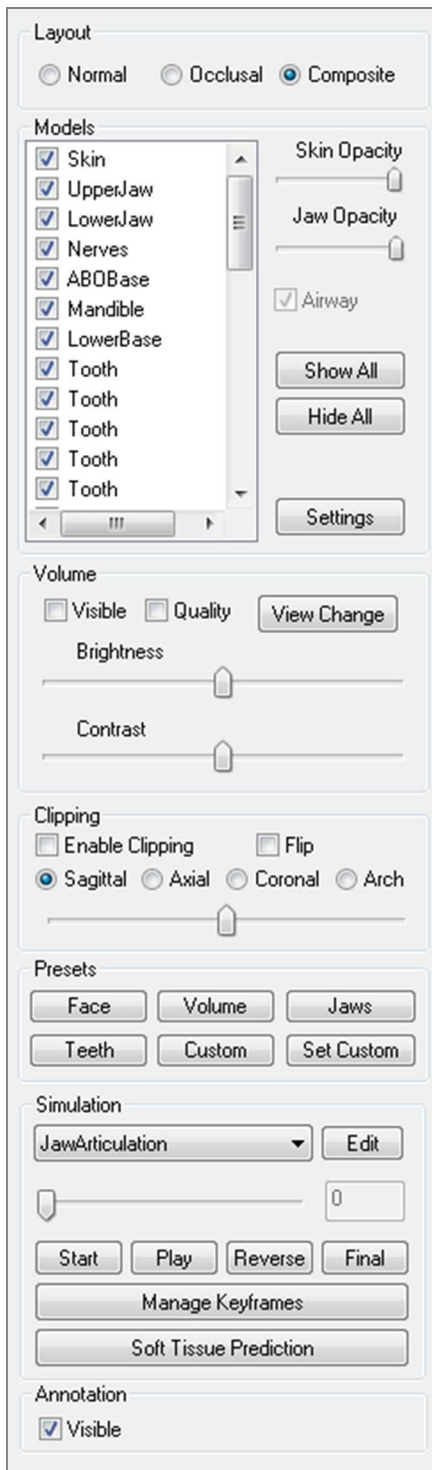

### Layout:

- Normal shows the digital models in the normal patient orientation along with the volume rendering if desired.
- Occlusal shows both arches from the occlusal perspective.
- Composite shows a composite of multiple views of the model all at once.

### Models:

- Models: The individual, digital models (implants, nerves, teeth, superimposition) can be turned on or off in the rendering window.
- Skin Opacity: Controls the opacity of the Skin model from the Anatomodel service or from 3DAnalysis.
- Jaw Opacity: Controls the opacity of the alveolar bone/ ABO base from the Anatomodel service.
- The Airway checkbox toggles the visibility of the airway measurement if one has been generated in Section Tab or Volume Render Tab.
- Show All and Hide All toggle the visibility of all the listed models.
- Settings: Control settings for items in the Models list. A model must first be selected in this list before the button is pressed.

### Volume:

- Select “Visible” to toggle the volume rendering on or off with the digital models.
- The View Change button allows volume rendering options, such as Soft Tissue, Teeth, etc.
- The Brightness and Contrast of the images can be adjusted with the slider.

### Clipping:

- Select “Enable” to slice the image along the predefined anatomical planes (sagittal, axial, coronal). Control the clipping with the scroll mouse or the slider.
- To switch a view to the opposite side, select “Flip.”

### Presets:

- Preset toggles that display predetermined views. A custom view can also be set.

### Simulation:

To create a new simulation:

- Select either the TeethMovement or JawMovement simulations, or press Edit to create a new simulation.
- Move the slider to the right to indicate the ending point.

- Click on a digital model to move it (either individual teeth or whole arches) with the move widget.
- After the final position is reached using the 3D move widget, press Start to go back to frame one.
- Press Play to view your simulated movement.
- Manage Keyframes lists the frames that compose the simulation for the selected model. (See page 130.)
- Press Soft Tissue Prediction to create a simulation of the soft-tissue prediction. This is only possible with the use of a 3DAnalysis face photo or AnatoModel Skin.

Annotation:

- Controls the visibility of comment markers in the rendering window.



Warning: Soft tissue prediction is an approximation and may not reflect actual results.

## Model: Rendering Window

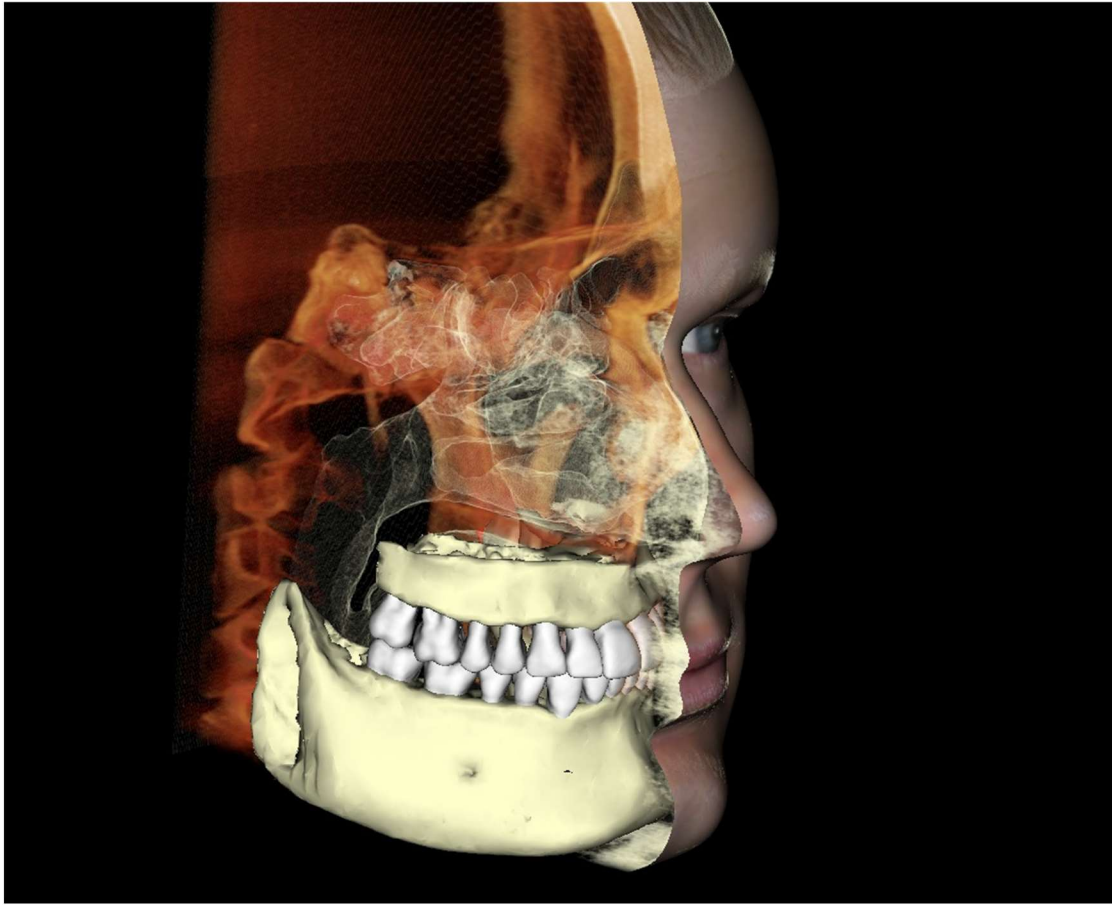

*This window allows the viewing of AnatoModels, 3D photographs, and simulation, all of which are services that must be ordered per case for this feature to work. These services provide excellent diagnostic data and case presentation material.*

Please refer to [Image Navigation \(pg. 32\)](#) for information about controlling and adjusting these images.



## Model: Custom Preset Setup

Visibility presets allow for easy switching between set views. The Custom option is set manually by the user. To configure these settings, click on Set Custom.

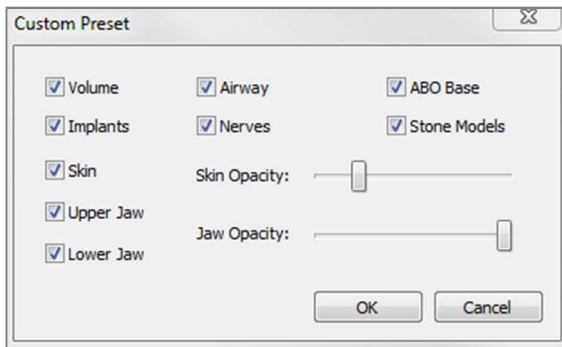

- Visibility checkboxes hide or show features in the rendering window.
- Skin Opacity: Controls the visibility of the face photo wrap from the Anatomodel workup file or 3DAnalysis. Varying degrees of transparency can be obtained with the slider.
- Jaw Opacity: Controls the visibility of the jaw models. Varying degrees of transparency can be obtained with the slider.

## Model: Simulations

Simulations may be created using any of the model objects in the software, such as implants and restorations, as well as models created by the AnatOM odel service.

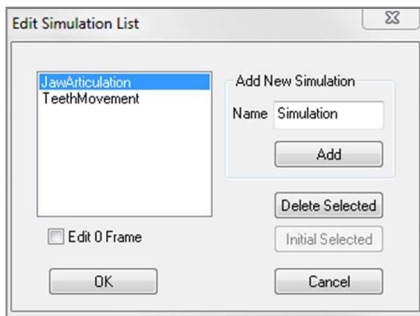

### Adding and Deleting Simulations

- Click Edit to open a list of all simulations.
- In the Name field, input the name of the new simulation and click Add. The new simulation will appear on the list.
- To delete a simulation, click on the simulation on the list to select it, then click Delete Selected.
- Initial Selected sets the current view state as Frame 0 for the selected simulation.
- If “Edit 0 Frame” is checked, then the initial frame of the simulation will be editable.

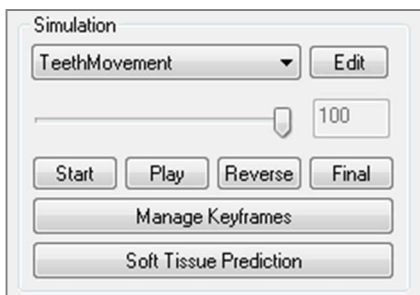

### Creating Simulations

- Move the slider to Frame 100. This will be the end state of the model.
- Select a model and the move widget should appear.
- Use the move widget to adjust the final position of the model.
- Moving the slider (Frame 0 to 100) will move the model between the initial and final positions.
- To adjust intermediate model positions, move the slider to an intermediate frame (between Frame 0 and 100). Use the move widget to adjust the model position.
- Moving the slider (Frame 0 to 100) will move the model from the initial position, through intermediate positions, and to the final position.

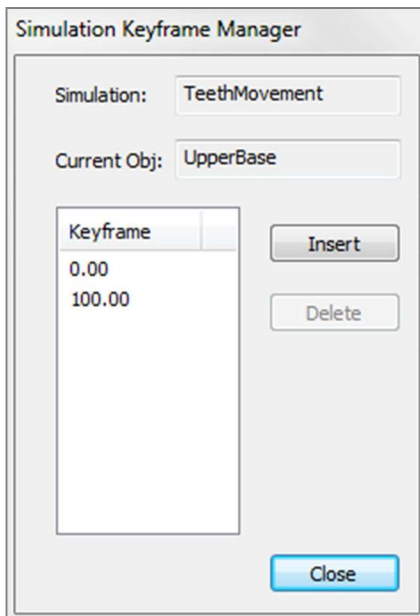

### Managing Keyframes

- Any animation frame in which a model position was adjusted becomes a keyframe.
- Keyframe management allows for preexisting keyframes to be easily identified, edited, or deleted as well as the creation of new keyframes.
- Click on Manage Keyframes to display a list of the keyframes for the selected model.
- The position of the model at existing keyframes can be edited by selecting the appropriate frame and repositioning the model.
- To insert keyframes, move the slider to the desired frame number and then click Insert. The model may then be moved to create a new state for that frame.
- To delete keyframes, click on the keyframe on the list and then click Delete.

Note: Manage Keyframes does not apply to skinwrap.

Please see page 134 for more information on Anatomodels and simulations.

# Common How to Tasks

## How to Trace a Nerve

- Go to the ArchSection Tab.
- Make sure the pano is in Slice Mode (not X-ray mode).
- Adjust focal trough such that the nerve pathway is visible in pano image.
- Move pointer to the pano image.
- Review the nerve pathway while using scroll wheel.
- If the nerve pathway is not clearly visible, adjust the focal trough.
- When the nerve pathway is identified through the pano image, press New Nerve in the Control Panel.
- Starting from the mandibular foramen, click point by point.
- If the nerve is not clearly visible, use the mouse scroll wheel to find the nerve and continue picking.
- Near the mental foramen, move the mouse to cross-section view.
- Use the scroll wheel to find the exit of the nerve.
- Pick points connecting the nerve exit.
- Press Done in the Control Panel to finish the nerve.



Warning: Any nerve that is traced in a way that does not conform to the actual pathway of the nerve can lead to surgical complications if diagnosis, treatment plans and/or actual treatment is based off of the incorrect tracing. It is critical for the end user to learn how to properly perform nerve tracings correctly. If you notice any inconsistencies or software problems with nerve tracing or have further questions or concerns about nerve tracing, please contact Anatomage support at (408) 885-1474 or email us at [info@anatomage.com](mailto:info@anatomage.com)

## How to Create Reports In Life Size

- Go to ArchSection Tab.
- Check “Adjust” in Vertical Range and Orientation.
- Adjust upper and lower limit by dragging green lines and then un-check Adjust.
- Adjust focal trough (arch spline) or re-draw arch spline by the clicking the Create Arch Spline button.
- Change Layout Mode to “Print Out.”
- Change to a desired layout using the Change Layout button.
- Adjust cross-sectional width and interval.
- Move cursor to set cross section in desired location.
- In Print Out mode, user cannot zoom the image since it is set to life size.
- If desired structure is not visible in cross section, adjust axial cursor or focal trough.
- Switch pano image to X-ray mode and turn on the ruler.
- Turn on the Arch Spline Ruler and turn off arch spline control points.
- Turn off the cursor if necessary.
- Go to the View menu and choose “Capture to Gallery.”
- Go to Gallery Tab.
- See Print Preview in the File menu and print out a test page.
- If you want to change the format, go to “Print Layout Setup” in the File Menu.
- If you want to use your own logo, replace the “printLogo.bmp” file in installation folder. This folder is typically in “C:\Program Files(x86)\Anatamage\InVivoDental”
- After the Print Layout Setup is changed, make sure you choose Print Out mode before recapturing the image. Otherwise the image could still be in the previous Print Layout Setup.

### Other View Tabs with Life-Size Printing

- Non-whole view, full-screen Section render (double-click a renderer to make full screen)
- TMJ in Print Out mode (Axial slice will not be life-size)
- Pano in Super Pano
- Super Ceph in Print Out mode



Warning: Any measurement that is incorrect can lead to surgical complications if diagnosis, treatment plans and/or actual treatment is based on the incorrect measurements. It is critical for the end user to learn how to perform measurements correctly and employ proper usage of all measurement tools. Measurement accuracy depends on the image data and the hardware scanner that generated the image data. The measurement cannot be more precise than the resolution of the image. Software reports the value based on user-picked points. Due to the nature of medical imaging, the boundary is not always well defined. The apparent boundary depends on the current brightness and contrast setting. The boundary may shift as the user makes adjustments to brightness and contrast. The user must understand the limitation of the measurement value before applying to the patient. If you notice any inconsistencies or software problems with measurements, or have further questions or concerns about using measurement tools correctly, please contact us at (408) 885-1474 or email us at [info@anatamage.com](mailto:info@anatamage.com)

## How to Create a Positive Airway View

- Go to Volume Render Tab.
- Select the Inverse preset.
- Reduce the opacity such that the internal structures start to appear.
- Change the viewpoint to Top View (Press Top View button in toolbar).
- Use sculpting tool to remove the undesired parts.
- Change the viewpoint and repeat sculpting operations.
- After the desired airway is isolated, increase the opacity.
- Adjust Brightness and Contrast to set the right visualization.
- (The Airway Measurement tool also shows a positive airway view that is color coded based on area. This inverse method lets you see the airway without color coding.)

## How to Create an AnatoModel Simulation and Video

*Simulations require the use of the AnatoModel service provided on a case-by-case basis from Anatomage. The AnatoModel service may include some or all of the following features:*

- Individually segmented, digital models of patient dentition
- Segmented digital models of patient mandible and maxilla
- 3D photograph overlay on the patient soft-tissue profile

*For additional information about the AnatoModel service, please contact Anatomage at (408) 885-1474 or email us at [info@anatomage.com](mailto:info@anatomage.com).*

- Go to Model Tab.
- Control Panel: Simulation, from the drop-down menu choose an existing simulation (TeethMovement, JawArticulation) or create a new one (select Edit).
- Move the slider to the very end (Frame 100).

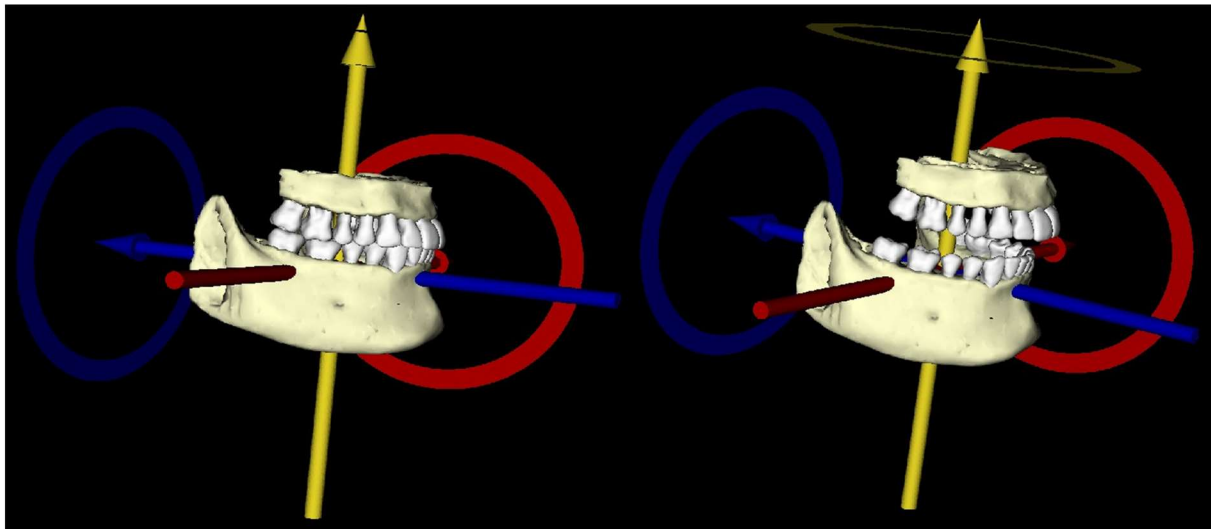
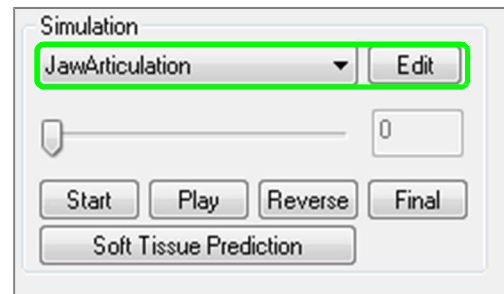

- Select a model adjust and the move widget should appear.
- Use the move widget to adjust the final position of the model.
- Moving the slider (Frame 0 to 100) will move the model between the initial and final positions.
- To adjust intermediate model positions, move the slider to an intermediate frame (between Frame 0 and 100). Use the move widget to adjust the model position.
- Moving the slider (Frame 0 to 100) will move the model from the initial position, through intermediate positions, and to the final position.
- The position of the models set on the frames can be edited through the Manage Keyframes option.



**View Sequencer:**

- To create a video of your simulation, select the View Sequence button from the Model Toolbar to open the View Sequencer Window.
- Much like the Volume Render View Tab (pg. 52), you can insert scenes with various volume orientations, clippings, colorizations, etc.
- Adjust rendering window image to desired settings (orientation, volume colorization, etc.) and move the Simulation slider to Frame 0.
- Press Insert in View Sequencer window.
- Adjust rendering window image to desired settings (orientation, volume colorization, etc.) and move the simulation slider to Frame 100.
- Press Insert in View Sequencer window.
- Test the video using the Start, Play/Pause and End buttons in the View Sequencer window.

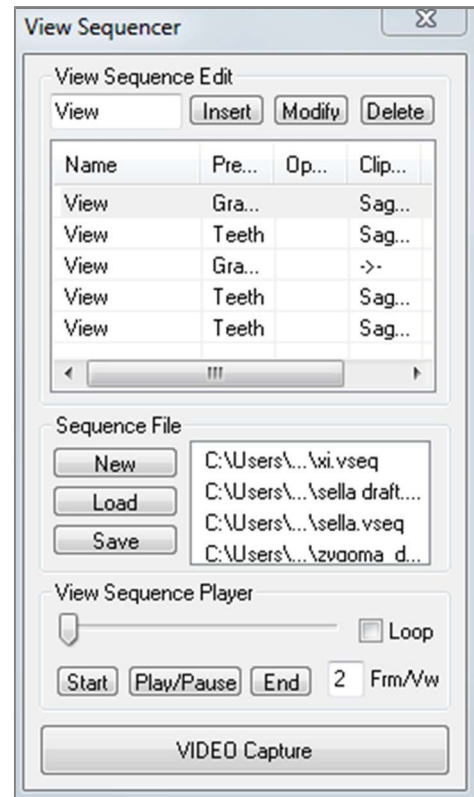

**Movie Capture:**

- If you are unsatisfied with the test video and view sequence, make the necessary changes (Insert new views or Modify/Delete existing views).
- If you are satisfied with the test video and view sequence, select VIDEO Capture to open the Movie Capture Window.
- Please refer to Volume Render Tab: View Sequence Section (pg. 52) for additional descriptions.
- Capture the view sequence to save your simulation as an AVI movie file.

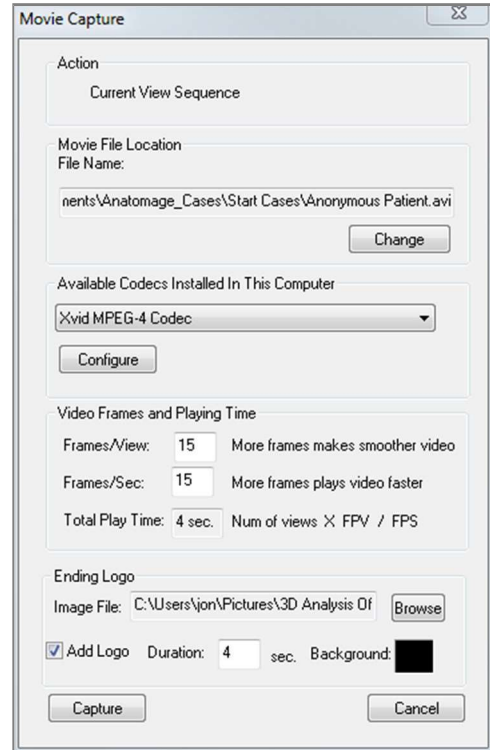

# Invivo5 Additional Modules

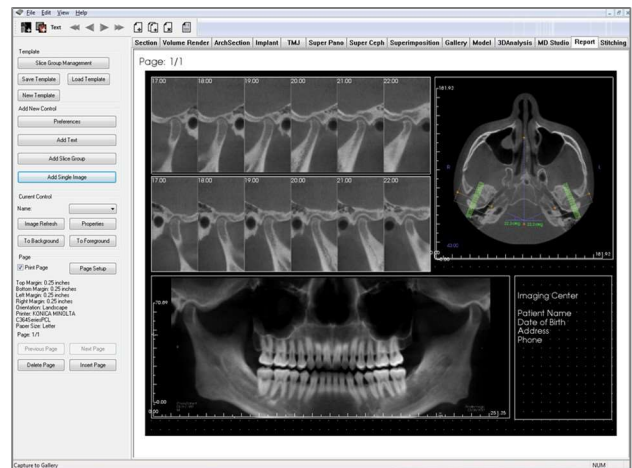
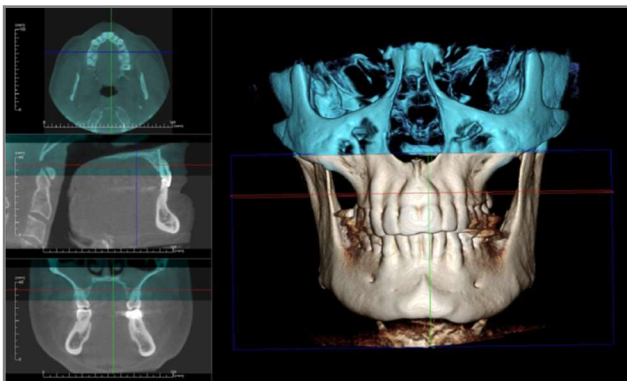
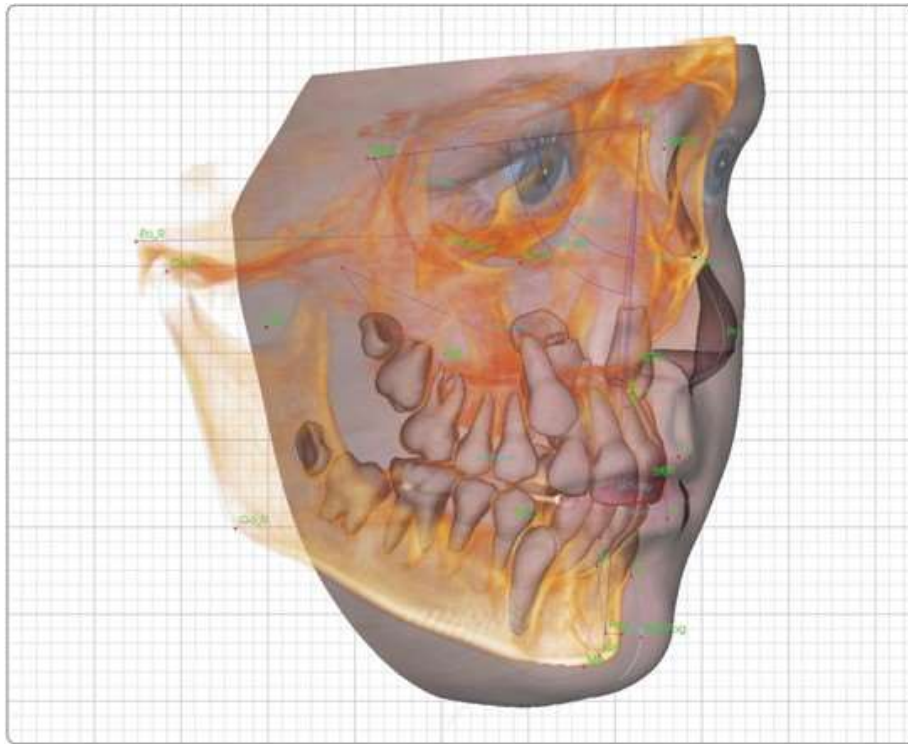

The following modules are sold separately. To find out more information about these modules, please contact Anatomage at (408) 885-1474 or at [info@anatomage.com](mailto:info@anatomage.com)



# 3DAnalysis Module Features

*The 3DAnalysis View Tab shows the patient in three-dimensional, reconstructed views and allows you to explore the internal structures and never-before-seen anatomy of the patient. With 3DAnalysis, the user can construct various landmarks and profiles, calculate 3D and 2D measurements, and report analytical results.*

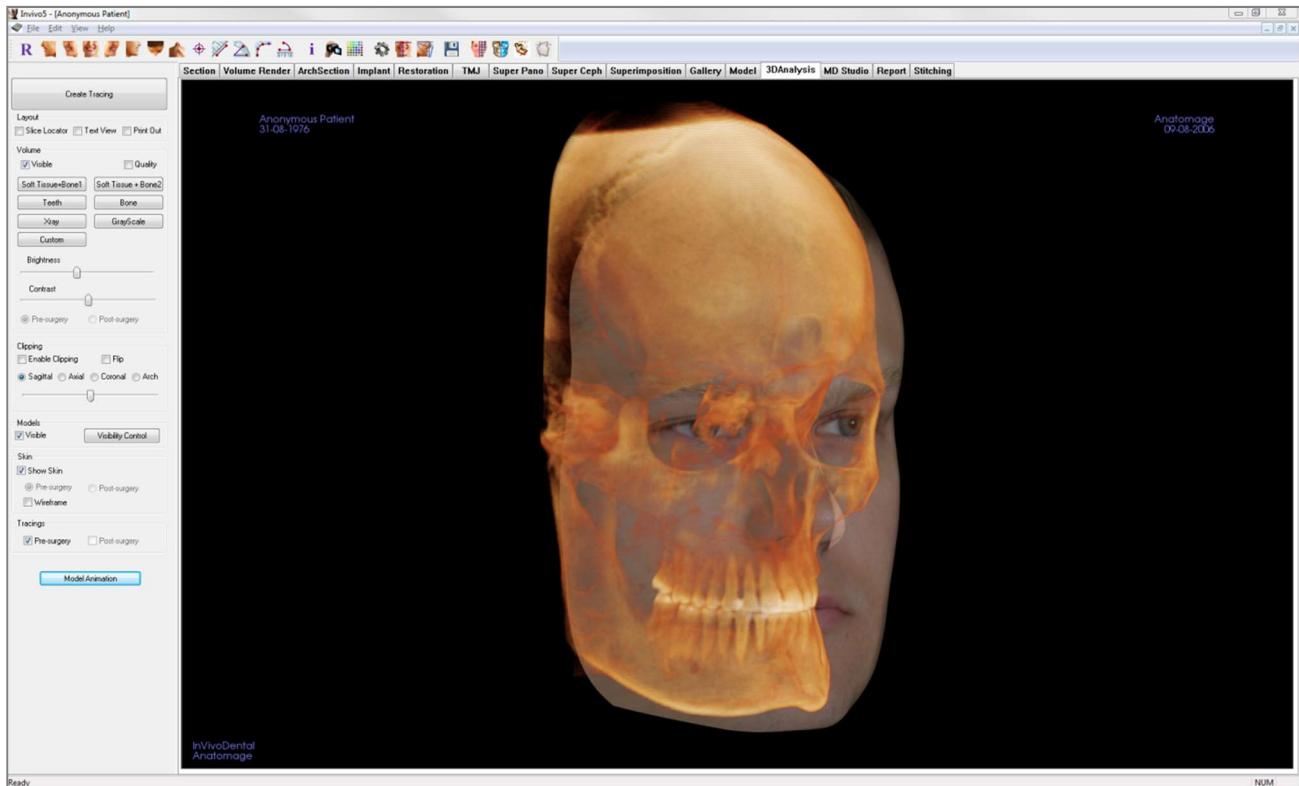

Warning: 3DAnalysis module is not a medical device and should be used as a reference or presentation tool only.

## 3DAnalysis: Toolbar

Shown below are the Toolbar and tools that are loaded with the 3DAnalysis View Tab:



Reset View: Resets the rendering window to the original view size.



Left View: Automatically orients the volume so the patient is facing left sagittal.



Left  $\frac{3}{4}$  View: Automatically orients the volume so the patient is facing 45° left sagittal.



Front View: Automatically orients the volume so the patient is facing the front.



Right  $\frac{3}{4}$  View: Automatically orients the volume so the patient is facing 45° right sagittal.



Right View: Automatically orients the volume so the patient is facing right sagittal.



Top View: Automatically orients the volume so you are oriented above the patient.



Bottom View: Automatically orients the volume so you are oriented below the patient.



Marker: When selected you may mark a point on the volume and X,Y, Z coordinates (transverse, sagittal, vertical) will appear. Clicking on the point and moving the cursor can modify points.. Click on the point and press the “delete” key to delete it. Control Panel features allow the values to be hidden or exported to a report.



Distance Measurement: Select this option and mark two points on the volume and distance will appear. Clicking on the point and moving the cursor can modify points. Click on the measurement and press the “delete” key to delete it.



Angle Measurement: Select this option and mark three points on the volume and the angle between them will appear. Clicking on their control points and moving the cursor can modify measurements. Click on the measurement and press the “delete” key to delete it. Control Panel features allow the values to be projected to 2D, hidden, or exported to a report.



Polygonal Measurement: When selected you may mark an unlimited number of points on the volume and the total between the first point and the last point will appear. Right-click your mouse to indicate that you have marked your last point. Clicking on the point and moving the cursor can modify points. Click on the measurement and press the “delete” key to delete it. Control Panel features allow the values to be projected to 2D, hidden, or exported to a report.



Arc Widget: Places an arc visual on the volume displaying the arc angle and radius of the circle containing the arc. Requires the placement of three points, the first marking the center of a circle and the last two marking the endpoints of the arc.



Information Display: Displays or hides case information embedded in the data.



View Sequence: Allows for the creation of custom camera sequences and AVI file movie capturing. Refer to the View Sequence description.



Visual Preference: Change color preference and define displaying type (For more information refer to 3DAnalysis Settings, pg. 167.)



3DAnalysis Settings: Define and change definitions of landmarks, measurements, references, analysis, norms, and soft tissue deformation ratios. Define and change other preferences related with 3DAnalysis.



Patient Orientation: Click to change patient orientation.



Tracing Tasks: Perform and edit the tracing tasks defined through series of picking landmarks and/or drawing profiles. (Refer to 3DAnalysis: Tracing Tasks for more information, pg. 146.)



Save Information: Opens a dialog containing commands for managing the 3DAnalysis configuration files, saving/exporting tracing data, and for building measurement norm data.



Create Face Photo: Opens the Create Face Photo Wrapping dialog. The dialog provides guided steps to producing a 3D photo wrap of the scan volume using textures from a photograph.



Superimpose Tracing: Opens the Tracing Superimposition dialog. The user can select a case and configure landmarks within this window to perform a landmark-based superimposition. This dialog also contains the Superimposed Tracing Visibility Controls.



3D Surgery: Opens 3D Surgery dialog. Surgical cuts, bone movement, and rotations can be simulated. The post-surgery volume can be further analyzed based on the analysis and the soft-tissue prediction.



Profilogram: Opens Profilogram dialog, converting the the pre- and post-surgery tracings (if available) to profilograms. Certain visibility options are available, and the registration settings can be changed.



**Warning:** Any measurement that is incorrect can lead to surgical complications if diagnosis, treatment plans and/or actual treatment is based on the incorrect measurements. It is critical for the end user to learn how to perform measurements correctly and employ proper usage of all measurement tools. Measurement accuracy depends on the image data and the hardware scanner that generated the image data. The measurement cannot be more precise than the resolution of the image. The software reports the value based on user-picked points. Due to the nature of the medical imaging, the boundary is not always well defined. The apparent boundary depends on the current brightness and contrast setting. The boundary may shift as the user makes adjustments to brightness and contrast. The user must understand the limitation of the measurement value before applying to the patient. If you notice any inconsistencies or software problems with measurements, or have further questions or concerns about using measurement tools correctly, please contact us at (408) 885-1474 or email us at [info@anatomage.com](mailto:info@anatomage.com)

## 3DAnalysis: Control Panel

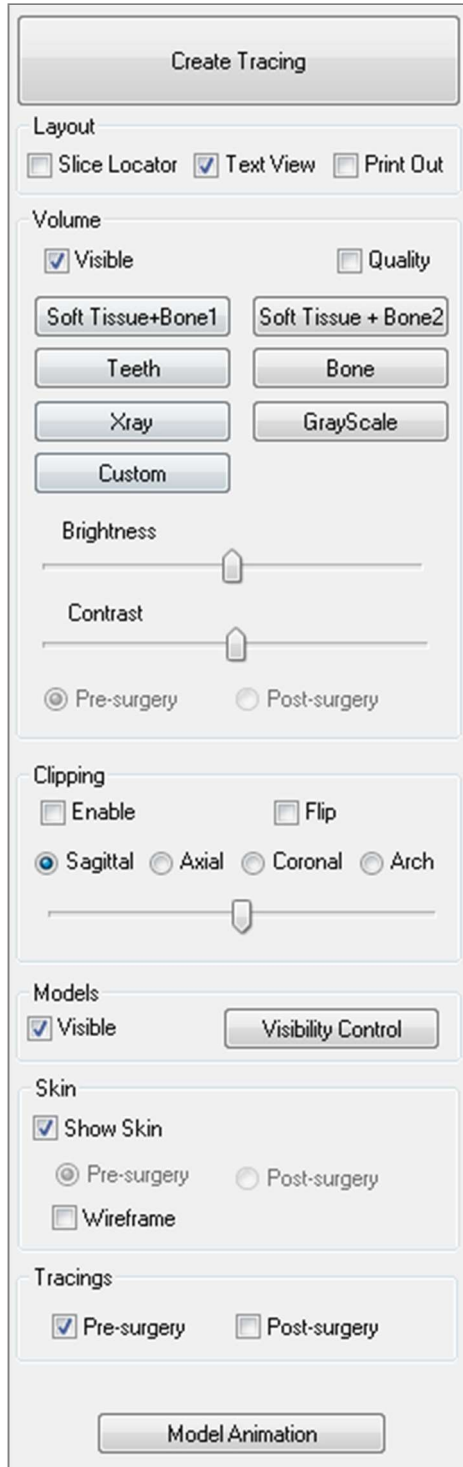

**Create Tracing:** Perform and edit the tracing tasks that are defined with some series of picking landmarks and/or drawing profiles. (Same as Tracing Tasks button on toolbar. For more details refer to 3DAnalysis: Tracing Tasks, pg. 146.)

**Layout:** Configure layout options for the rendering window.

- **Slice Locator:** Aid for picking landmark location.
- **Text View:** Provides visibility options and values for landmarks, measurements, reference planes, and analysis configurations.
- **Printout:** Changes rendering window to a life-size printer-friendly version of the volume and tracing. Not compatible with slice locator view.

**Volume Control:**

- **Visible:** Allows the 3D volume rendering to be turned on or off from view.
- **Quality:** Box can be clicked on or off to further enhance the quality of the image.
- **View Presets:** Different settings allow for better visualization of certain anatomic structures, soft tissue profiles, hard tissue, etc. This is achieved by displaying specific densities with specific colors and transparencies.
- **Brightness & Contrast:** Can be adjusted for each of the presets to enhance your image.

**Clipping:** Click the “Enable Clipping” box to slice the image along the predefined anatomical planes (sagittal, axial, coronal, and arch). Scrolling the mouse wheel or moving the slider will move the clipping plane. To switch a view to the opposite side, click “Flip.” Fine clipping is activated by scrolling with the mouse scroll wheel while the “Ctrl” key is pressed.

**Model Control:**

- **Visible:** Allows the 3D models to be turned on or off from view.
- **Visibility Control :** Select individual 3D Models to be turned on or off from view.

**Skin Control:**

- **Show Skin:** Turns either pre- or post-surgery skin on or off.
- **Wireframe:** Converts the skin to a wire-mesh form.

**Tracings:**

- **Toggles the visibility of the pre-and post-surgery tracings.**

**Model Animation:**

- **Create, edit, or play model simulations within the rendering window.**

## 3D Analysis: Coordinate System

### Context:

The coordinate system is very important for any three-dimensional (3D) system. It defines the structure for subsequent measurements and analyses. Even though the absolute measurements such as linear distance or angular measurement are invariant to the coordinate system, any projected measurement, such as the angle projected to mid-sagittal plane is significantly influenced by the coordinate system. Thus, it is essential to establish a sound coordinate system before any measurements or analysis can be done.

There is a coordinate system for 2D images, too. However, given its simplicity, one may not realize it as a coordinate system but more or less direction. In general, for a two-dimensional system, one simply needs to determine a single axis and the other is often determined as orthogonal to the first. In traditional 2D cephalometrics, the Frankfort horizontal plane could serve as the horizontal axis. By default, the vertical axis is defined from this Frankfort plane.

In a 3D coordinate system, however, it is more complicated. One has to define three axes, and (for a typical Cartesian coordinate system) they must be orthogonal to one another. Additionally, the origin of the coordinate system could be anywhere but preferably lying on an anatomical feature. The challenge is that anatomical landmarks and coordinate axes are not necessarily aligned; a line connecting two landmarks may not serve as the correct coordinate axis.

From a mathematical perspective, any coordinate system based on finite number of 3D coordinates is relatively simple linear algebra. Thus, any desired coordinate system can be established by a linear combination of the landmark coordinate values. Such definitions may be difficult to understand for clinicians and may not have anatomical meaning or agree with existing analysis schemata.

In this software, we propose a coordinate system construction scheme with the following essential goals:

1. Support for existing clinical concepts
2. Freedom to establish user-defined coordinate system(s)
3. Interface that is easy to set up and understand

Coordinate System: Click to change coordinate system. (Refer to 3DAnalysis: Coordinate System for more information, pg. 141.)

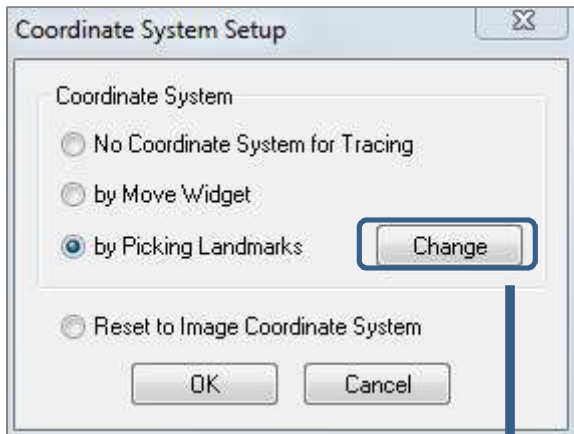

- No Coordinate System for Tracing: Do nothing to define the coordinate system. Use current coordinate settings.
- by Move Widget: Use Move Widget to define the coordinate system before performing tracing tasks.
- by Picking Landmarks: Define the coordinate system by picking landmarks predefined on the Define Coordinate System dialog (below).
- Reset to Image Coordinate System: Cancel the current coordinate system definition and return to the original patient coordinate system.

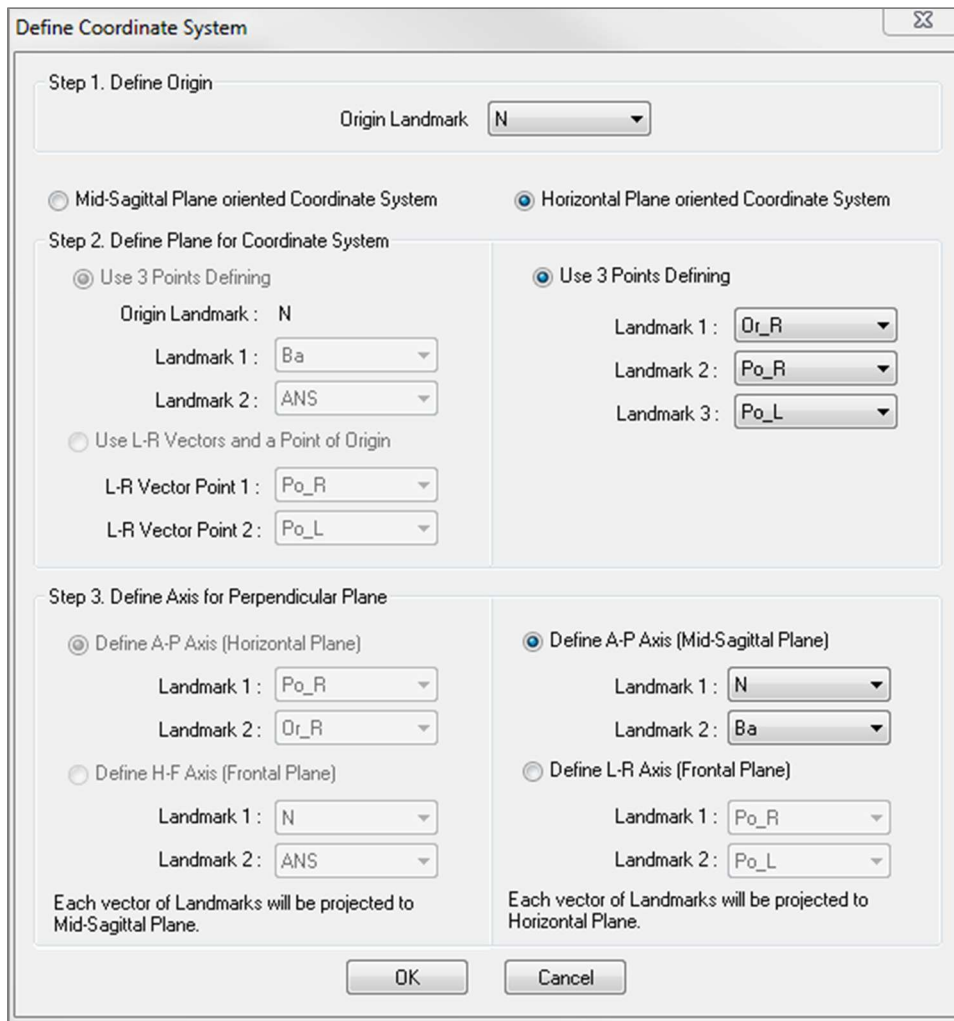

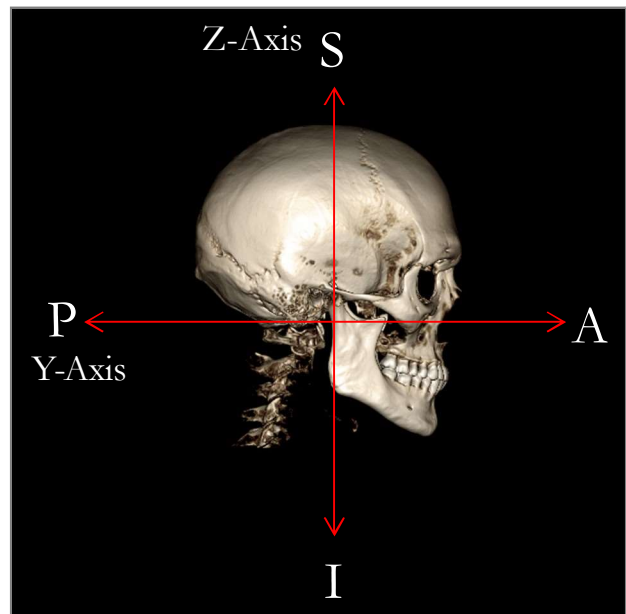
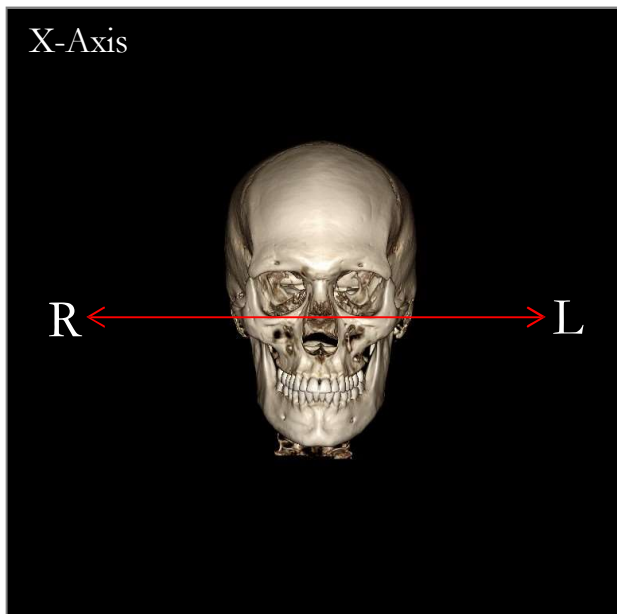

Defining the Coordinate System by Picking Landmarks:

Two methods of defining the coordinate system are available in 3DAnalysis. You can switch between the methods in the Define Coordinate System window by pressing the Coordinate System button in the toolbar, selecting “By Picking Landmarks” and pressing Change. Alternatively, the Define Coordinate System window can be accessed in a similar manner but through the Tracing Guide window. The images above show the orientation of axes and anatomical terms of location.

#### Step 1: Define Origin

Irrespective of which method you choose when defining your coordinate system, you must select a landmark to serve as the origin for measurements, references, and your analysis.

Next, choose the method of determining the coordinate system:

- Mid-sagittal plane-oriented coordinate system
- Horizontal plane-oriented coordinate system

#### Step 2: Define Plane for Coordinate System (Mid-Sagittal Plane Method)

The mid-sagittal plane can be established by two methods:

1. *Use 3 Points Defining:* Define two additional points. With the origin defined (Step 1), a total of three points defines the mid-sagittal plane.  
Ex: Origin – nasion, two points – anterior nasal spine and basion.
2. *Use L-R Vectors and a Point of Origin:* Choose two points on either side of the volume (left and right sides) to create a vector. The mid-sagittal plane will be set normal to the vector and intersecting the origin.  
Ex: Origin – nasion, two points – left and right porion.

The origin must be located on the mid-sagittal plane. Step 3 will determine the perpendicular axes.

Step 3: Define Axis for the Perpendicular Plane (Mid-Sagittal Plane Method)

From the mid-sagittal plane, the X-axis is defined as normal to the plane. The perpendicular Y- and Z-axes (sitting on the plane) can be determined by projecting a vector onto the mid-sagittal plane to define one and setting the other as normal to this plane. There are two manners of determining the Y- and Z-axes using this method:

1. *Define A-P Axis (Horizontal Plane)*: choose two landmarks to connect anterior to posterior and serve as the horizontal plane.  
Ex: Point 1 – right orbital, Point 2 – right porion → Frankfort horizontal plane
2. *Define F-H Axis (Frontal Plane)*: choose two landmarks to connect head to foot and serve as the vertical plane.  
Ex: Point 1 – nasion, Point 2 – anterior nasal spine → frontal plane

\* \* \*

Step 2: Define Plane for Coordinate System (Horizontal Plane Method)

The horizontal plane can be established using three landmarks.

Ex: Point 1 – right orbitale, Points 2, 3 – left and right porions  
Defines the 3D Frankfort horizontal plane

The origin must be located on the horizontal plane. Step 3 will determine the perpendicular axes.

Step 3: Define Axis for the Perpendicular Plane (Horizontal Plane Method)

From the horizontal plane, the Z-axis is defined as normal to the plane. The perpendicular X- and Y- axes (sitting on the plane) can be determined by projecting a vector onto the horizontal plane to define one and setting the other as normal to this plane. There are two manners of determining the X- and Y-axes using this method:

1. *Define A-P Axis (Mid-Sagittal Plane)*: choose two landmarks to connect anterior to posterior and serve as the mid-sagittal plane.  
Ex: Point 1 – basion, Point 2 – nasion
2. *Define L-R Axis (Frontal Plane)*: choose two landmarks to connect laterally and serve as the frontal plane.  
Ex: Point 1 – left porion, Point 2 – right porion

When Steps 1-3 are completed, press the OK button to save the settings and close the Define Coordinate System window.



**Note:**

In traditional 2D cephalometry, the sagittal direction is constructed between porions. In 3D cephalometry, there is a dilemma in that the sagittal axis (porion to porion) and the mid-sagittal plane (nasion, anterior nasal spine, sella) cannot be achieved simultaneously.

If you choose porion-to-porion to be the sagittal axis, the orientation of the mid-sagittal plane is defined by the axis and one landmark could define it completely. Consequently, the other landmarks may sit close but not exactly on the mid-sagittal plane.

Alternatively, if you construct the mid-sagittal plane using three landmarks (nasion, anterior nasal spine, sella) then the sagittal axis is defined from the mid-sagittal plane. This axis may not be parallel to the vector connecting the two porion points.

Using 3D cephalometrics allows for more accurate measurements and analysis. However, there are discrepancies with traditional 2D analysis (such as the one listed above, so caution should be used in defining the coordinate system, landmarks, references, etc. to minimize these differences.

## 3DAnalysis: Tracing Tasks

Now that the patient coordinate system is established, start picking points. The first set of points will be your coordinate-system associated landmarks, followed by other landmarks and profiles.



Note: If you are having trouble placing points on the volume due to the predefined rendering, angle, and clipping settings, please refer to the 3DAnalysis: Tracing Guide section (pg. 178) to edit your view states.

### Tracing Tasks:

To begin tracing your rendered volume, press either Create Tracing in the Control Panel or the Tracing Tasks button in the toolbar.

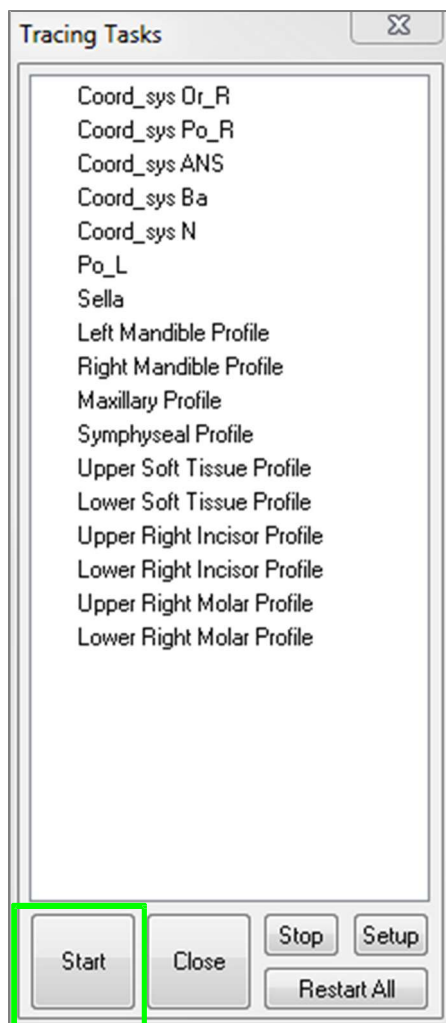
The Tracing Tasks window should open and list the order of Tracing Tasks to be performed. By default, the window will open in editing mode. (See Tracing Tasks – Editing Mode). Once a tracing task has been started, you may begin picking points on the rendered volume to define landmarks and profiles.



Start: Starts the first listed undefined tracing task. The tracing tasks required for defining the coordinate system will be done first and prefixed with “Coord\_sys.” After defining the coordinate system Tracing Tasks, you can select specified tracing tasks by double-clicking it or pressing the Start button. The currently selected tracing task will be marked with a cross-hair symbol  and completed tracing tasks will be marked with a check .

- Close: Stops current tracing task and closes the Tracing Task window.
- Stop: Stops current tracing task and returns to the editing mode in the tracing task window.
- Setup: Opens the Tracing Guide window.
- Restart All: Discards completed tracing tasks and restarts from the first tracing task.

### Tracing Tasks – Editing Mode:

To enter Editing Mode simply open the Tracing Tasks window by clicking on Create Tracing. When in editing mode, one can modify completed landmark positions and profile lines. Landmark positions and profile points are highlighted on the volume in the rendering window. Move the mouse over the landmark or profile point. Left-click and drag the landmark or profile point to the new desired location. Releasing the left-button will save the new position of the landmark or profile point on the volume. Selecting a landmark or profile point will also highlight the point on the Slice Locator, where the point can be further adjusted. This technique will help to move and adjust profile lines quickly without re-tracing the entire feature.

## Tracing Task Examples and Tips

### Notes About Landmarks/Profiles:

- Many common landmarks are associated with profile tracings. These landmarks will therefore only show on the volume and have a coordinate value when the corresponding profile tracing is completed (ex. Condyle point Co\_R with the Right Mandibular Profile). Contact Anatomage Support and see the section Default Tracing Tasks and Landmarks (pg. 71) for more information about these automatic definitions.
- Users can pick points for landmarks or profiles on models. These models can be in the form of Skin or Tooth Anatomodels as well as models created and/or imported into the Model Tab from MD Studio. (MD Studio is an add-on module for Invivo5.)

The following pages will demonstrate profiles and associated landmarks that are integrated into the default configuration file from the initial installation.



Warning: Results produced by the software's diagnostic and planning tools are dependent on correct selection of landmarks by the user in the 3D volume. The software reports values based on these user-picked points. Due to the nature of medical imaging, the boundaries are not always well defined. The apparent boundaries depend on the current brightness and contrast settings. The boundaries may shift as the user makes adjustments to brightness and contrast. The user must understand the limitations of the measurement values before applying to the patient. If you notice any inconsistencies or software problems with measurements, or have further questions or concerns about correctly using measurement tools correctly, please contact us at (408) 885-1474 or email us at [info@anatomage.com](mailto:info@anatomage.com)

### Mandibular Profile

Be sure to include the profiles of the condyle, mandibular notch, and corpus. Follow the curve to include the gonion and antegonion. The antegonion, condyle, and gonion locations will be determined in the software through the profile. Always verify the location of the antegonion; open the tracing task to activate Edit mode and drag to modify.

Structure contains:

Co – Condyle

Go – Gonion

Ag – Antegonion

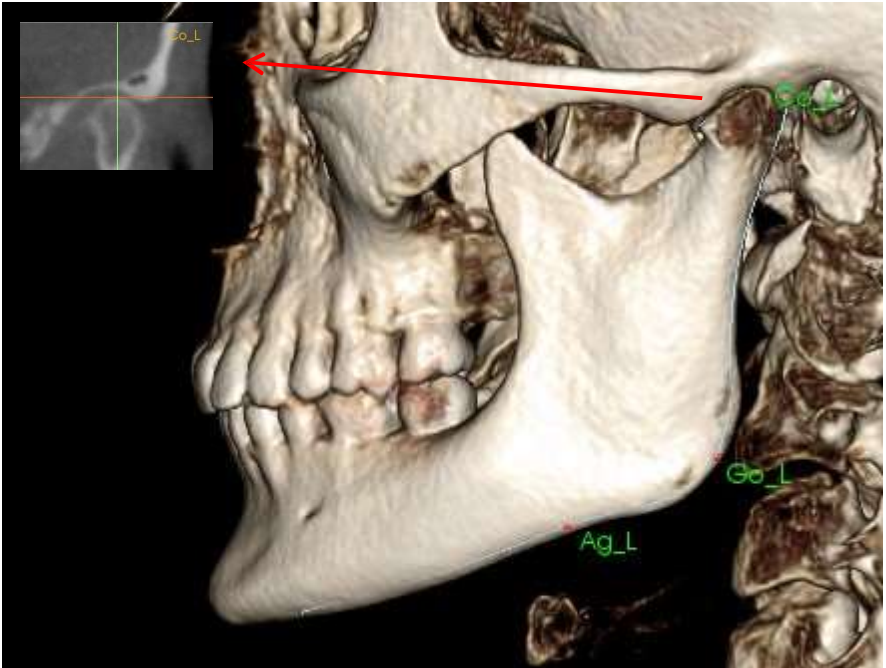

### Maxillary Profile

Start the profile near the anterior interface of the upper incisor and follow the profile of the maxilla back to the posterior interface of the incisor. Adjust the brightness and/or contrast levels to show the anterior nasal spine (ANS) and include that in the tracing profile. It is recommended that you place a profile point at or very near the ANS. Note: Using the default user-picked ANS will replace the automatically-defined profile ANS. The Pr point will be placed at the location of the first click.

Structure contains:

ANS – Anterior Nasal Spine

PNS – Posterior Nasal Spine

A – A point

Pr – Prosthion

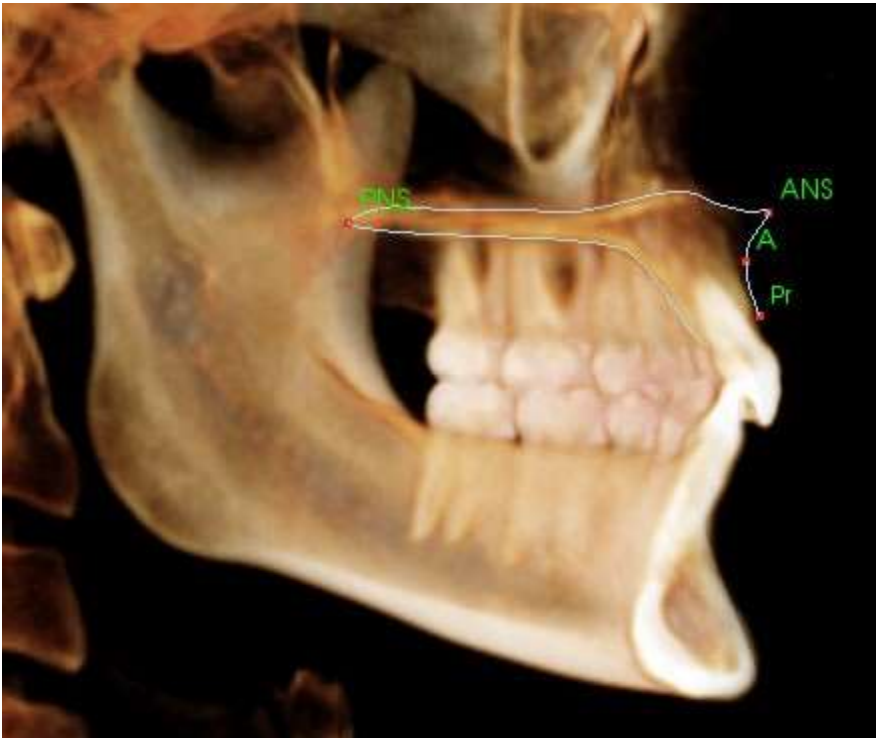

### Orbital Profile

Trace the most anterior part of the ridge usually noticeable based on the brightness (whiteness) of the bone around the orbit. Follow this ridge from the zygomatic suture to about the medio-orbital. If you use the orbitale as a landmark (ex: for Frankfort horizontal), it is recommended that you include this point as a profile point in the tracing. A user-defined Or\_L or Or\_R landmark will override the automatic Or landmarks.



Structure contains:

Or – Orbitale

### Soft-tissue Profile

(Upper)

Adjust the brightness and/or contrast of the image to see the soft-tissue profile. Trace it from the top of the head to the lips. The upper soft-tissue should include the profile of the upper lip.

Structure contains:

Soft N – Soft Tissue Nasion

Pn – Pronasale

Ls – Labrale Superius

Sts – Stomion Superius

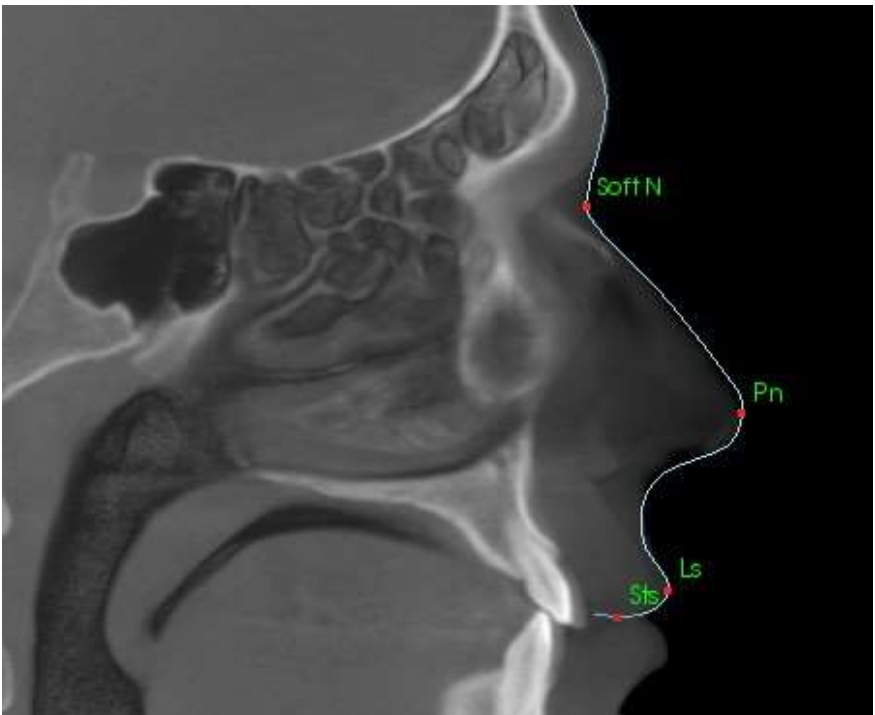

### Soft-tissue Profile

#### (Lower)

Adjust the brightness and/or contrast of the image to see the soft-tissue profile. Trace it from the lips to below the chin. The lower soft-tissue should include the profile of the lower lip.

Structure contains:

Sti – Stomion Inferius

Li – Labrale Inferius

Ils – Soft-tissue B point

Soft Pog – Soft-tissue Pogonion

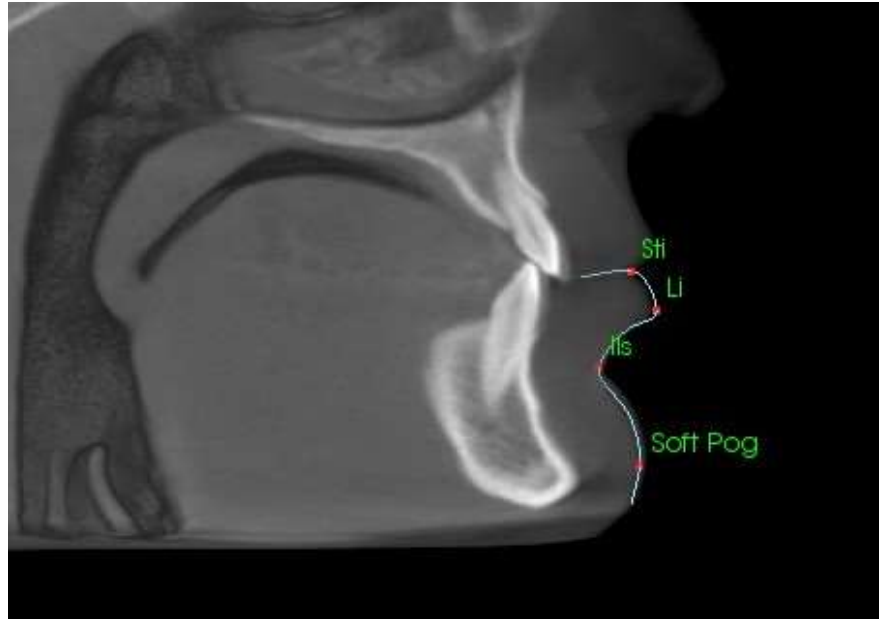

### Symphyseal (Mandible) Profile

The profile should start near the anterior interface of the lower incisor, follow the curvature of the symphysis and finish at the posterior interface of the lower incisor. The Id point will be placed at the location of the first click.

Structure contains:

Id – Infradentale

B – B point

PM – Protuberance Menti

Pog – Pogonion

Gn – Gnathion

Me – Menton

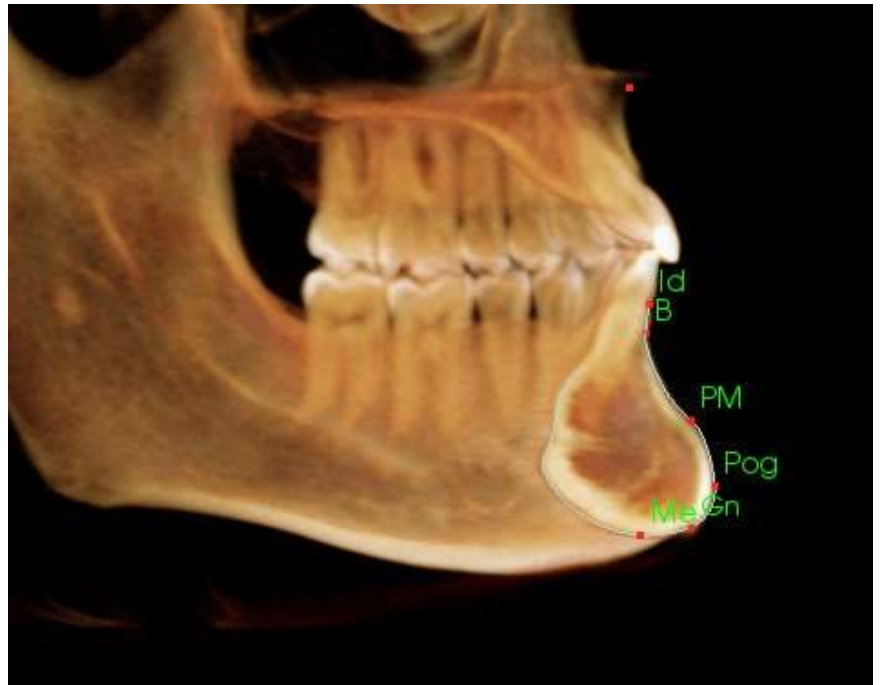

### Teeth (Molar)

Place the first point at the tip of the anterior root for the molar. Place the next point at the tip of the anterior cusp. Place the final point at the tip of the posterior cusp. This procedure is applicable to the upper and lower molars (only lower molar shown at right).

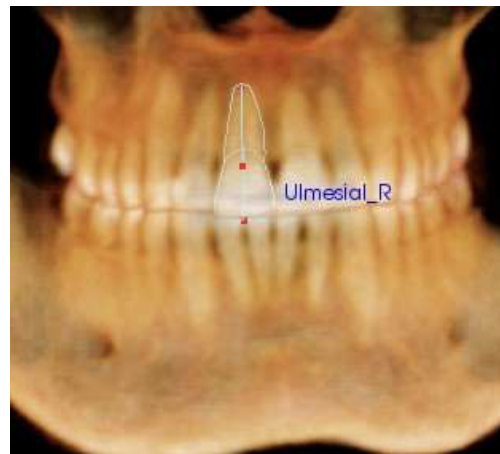
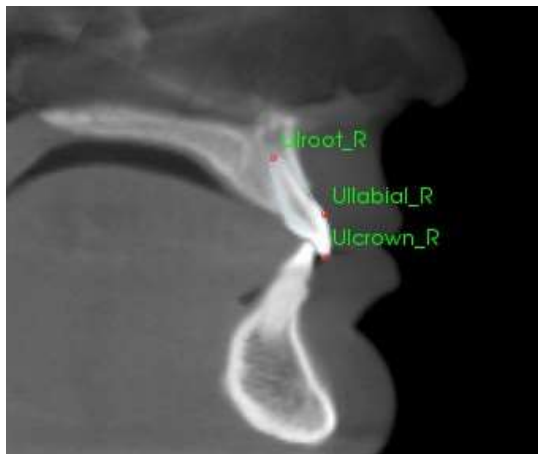

### Teeth (Incisor)

Place the first point at the tip of the root for the incisor. Place the next point at the tip of the crown. Place the final point on the most labial side of the tooth. This procedure is valid for both the upper and lower incisors (only upper is shown).

Frontal Incisor Profiles require an additional fourth point, located at the most mesial point of each central incisor. When performing the tracing task, trace the first three points using the sagittal view and then use the frontal view to place the fourth point. Use the toolbar orientation buttons to rotate the volume during a tracing task.

Note: When adding the Frontal Incisor Profiles to the current tracing task list, you must first ensure that the frontal lateral profiles are no longer on the list before they can be added. The two types of frontal incisors are not intended to be used simultaneously.

### 3DAnalysis: Text View

Once the landmarks have been defined on the volume, visualize the results of the analysis. Most of this will happen in the Text View, available under the Layout section of the Control Panel. Once Text View has been checked as visible, a pane will appear on the right side of the screen. If any of the contents extend beyond the bottom of the screen, use the mouse wheel to scroll down the list. Text View includes the following tabs:

Landmark	Measurement	Reference	Analysis
-- Cranial Base			
Or_R	(-31.4, 11.1, -31.3)		On
Po_L	(50.0, 88.1, -31.3)		On
Po_R	(-50.7, 88.1, -31.3)		On
N	(0.0, 0.0, 0.0)		On
Or_L	(34.0, 11.6, -31.3)		On
Sella	(0.5, 66.6, -14.3)		On
Ba	(0.3, 91.9, -52.7)		On
-- Maxillary			
Pr	(-0.0, -6.3, -62.6)		On
A	(-0.0, -2.7, -53.2)		On
ANS	(-0.0, -7.1, -48.3)		On
PNS	(0.0, 52.1, -56.1)		On

**Landmark:** List of currently traced landmarks and the respective position values. Clicking the landmark line can set the display of the landmark name On/Off on the volume. Clicking the group line can set the display of all landmarks in that group On/Off at the same time.

**Measurement:** List of respective values of available measurements defined in the analysis. Clicking the measurement line can set the display of the measurement name, value, and reference line On/Off on the volume. Clicking the group line can set the display of all the measurements of the group as On/Off at the same time. When measurements are calculated and projected onto a plane, a '\*' is shown in the unit column.

Landmark	Measurement	Reference	Analysis
-- Horizontal Skeletal			
ANB Ang_2D	degree*	0.93	Off
SNA Ang_2D	degree*	80.81	Off
SNB Ang_2D	degree*	79.88	Off
Pog to NB_2D	mm*	4.13	Off
GoGn to SN Ang_2	degree*	25.43	Off
Y-(growth) Axis Ang	degree*	50.33	Off
-- Vertical Skeletal			
OP to SN Ang_2D	degree*	14.21	Off
-- A-P Dentition			
U1 to NA_2D	mm*	2.87	Off
U1 to NA Ang_2D	degree*	17.33	Off
U1 to L1 Ang_2D	degree*	148.12	Off

Landmark	Measurement	Reference	Analysis
-- Reference Planes			
Mid-Sagittal plane			Off
Frontal plane			Off
Frankfort Horizontal Plane R			Off
Maxillary Plane			Off
Mandibular Plane			Off
Ba-N Plane			Off
A FH Perp			Off
Occlusal Plane R			Off
N-Occl Perp			Off

**Reference:** List of currently available references. Clicking the reference line/plane can set the display the name and line/plane of the reference line/plane On/Off on the volume. Clicking the group line can set the display of all references of the group as On/Off at the same time.



Analysis: Report and wigglegram of currently available measurements in the specified analyses. Display current ethnic norm group. Click the norm group name to change the default ethnic norm group.

Clicking the analysis name (“Default” in the left example) will make all measurements within that analysis visible in the rendering window. Clicking an analysis subgroup name will turn on visibility for any measurements under that subgroup.

For VCA analyses, clicking the analysis name will turn on visibility for any VCA-configured measurements in the rendering window. Clicking an analysis subgroup name will turn on visibility for any VCA-configured measurements under that subgroup.

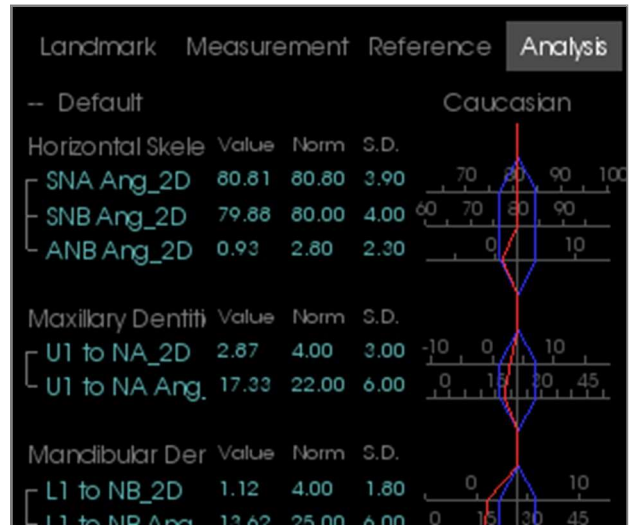

### Colored Wigglegram

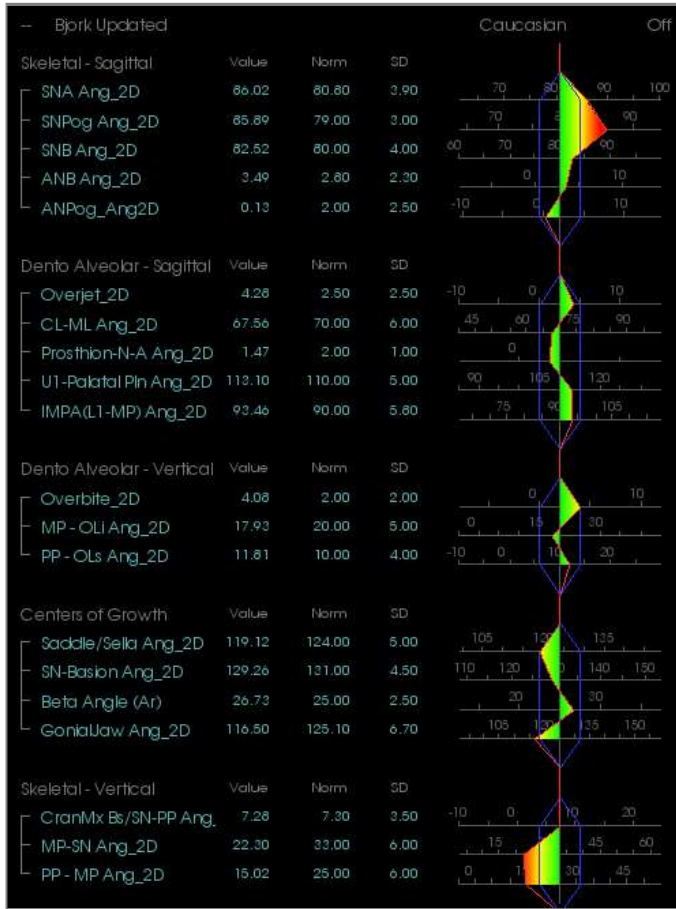

The wigglegram features a user-customizable color gradient to convey analysis results. The color corresponds to the number of standard deviations the measurement value differs from the norm.

Ex: Values that differ between 0 and 1 SD will show up as a blend of green and yellow.

Configure visibility settings in the Visual Preferences dialog:

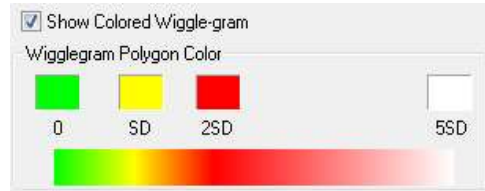

Features:

- (Color) Visibility On/Off
- Customizable 4-Color Gradient
- Color Correlation with VCA Color Indicators
- Compatible with Frontal Analysis Wigglegram (see below).



Warning: The analysis results are dependent on the norm values that are configured within each configuration file, which may contain predefined as well as user-defined data. The predefined norms that are available upon installation may or may not be based on accepted clinical values for the respective measurements. Users must verify the validity of norm values that will be used before applying this function on patient data. For further questions regarding the function, configuration, and validity of norm data, please contact the Anatomage Support Department at (408) 885-1474 or [info@anatomage.com](mailto:info@anatomage.com).

### Frontal Analysis Mode:

The measurement values and wigglegram take a new format when an analysis is configured to be of a “frontal” variation. Refer to the 3DAnalysis: Advanced Analysis Configurations section (pg. 159) for more information.

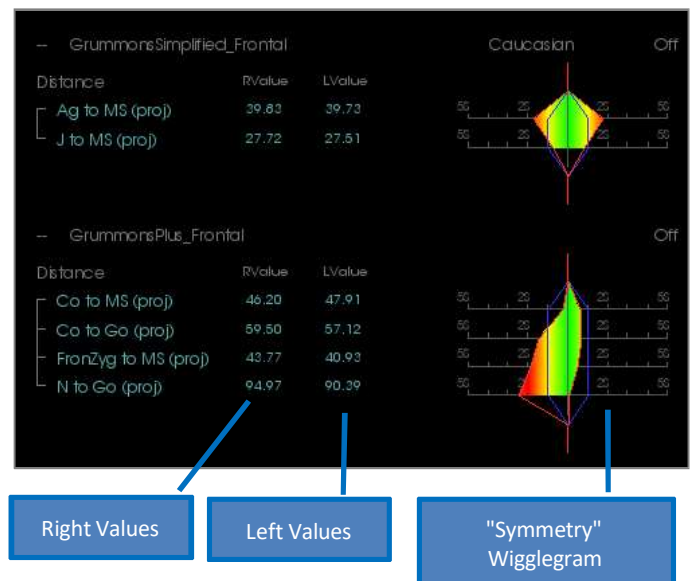

### 3DAnalysis: VCA Mode

3DAnalysis capitalizes on the fact that a large part of an analysis can occur visually. With the introduction of VCA (Visual Craniometric Analysis) colored indicators, an analysis can be customized to reveal an overall picture of a patient's clinical state by providing only the necessary level of numerical detail without overburdening the user. While the quantitative information is still available, the colored indicators draw attention back to the most necessary part of the analysis – the volume – while also saving time and effort.

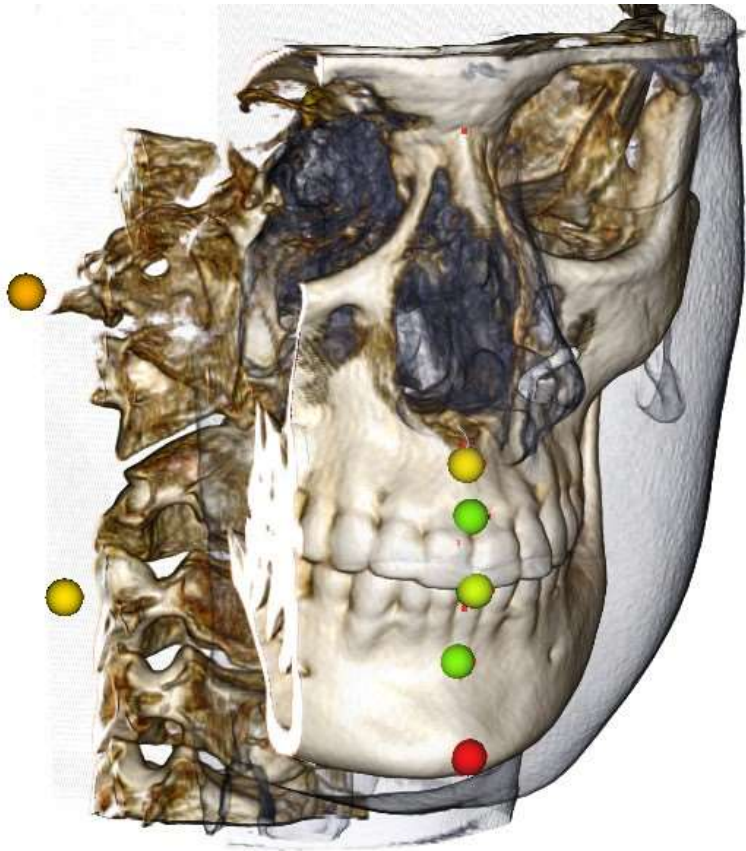

How It Works: VCA colored ball indicators are tethered to individual measurements. When these measurements are selected in the Analysis Tab (by subgroups or analysis name), the VCA ball indicators will appear in the rendering window with a color that is dependent on the deviation of the measurement value from the norm. The proper configuration can allow the user to determine the areas that require attention without needing to see the exact measurement values.

Configuring a VCA:

- Change the name of the analysis to indicate a VCA configuration
- Configure individual measurements values to have VCA landmarks
- Trace the case, turn on VCA landmarks in the Text View

Continue on in the section for more details on these tasks.

### Choose An Analysis/Rename to VCA Configuration:

Any analysis can be configured to include VCA indicators. Open the 3DA Setup dialog with the  icon and navigate to the Analysis Tab.

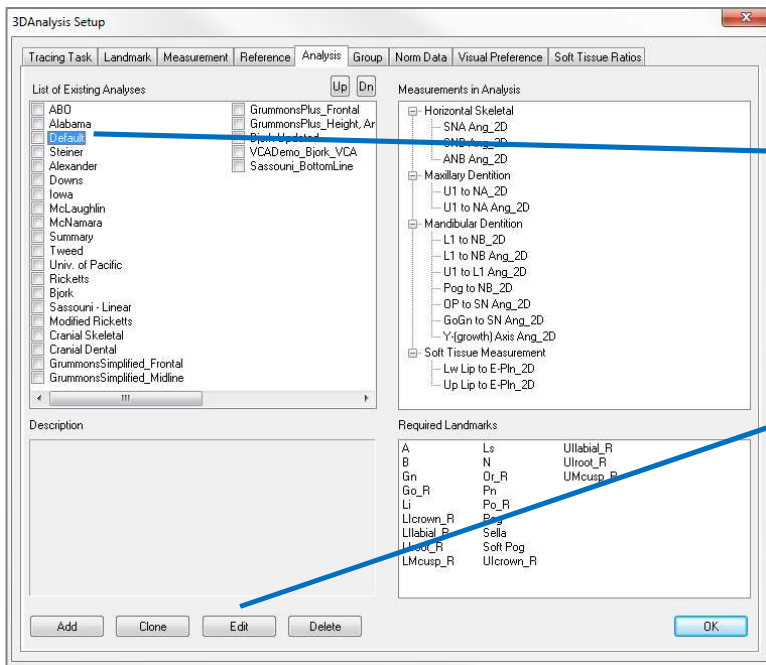

1. Left click on the name of the desired analysis. "Default" chosen in this example.

2. Click the Edit button.

3. The Define/Edit Analysis window will appear. Change the name to end in "\_VCA".

4. Click OK to exit the Define/Edit Analysis window. Then, click OK to exit 3DA Setup completely.

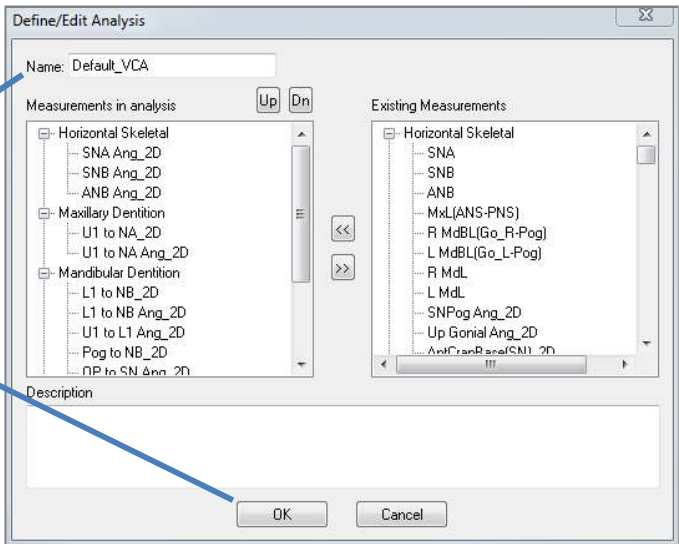

## Configure Individual Measurements:

Open the 3DA Setup dialog with the  icon and navigate to the Measurement tab of this window (third from the right). For this step, it would help to have a list of measurements handy as a reminder of which ones to configure.

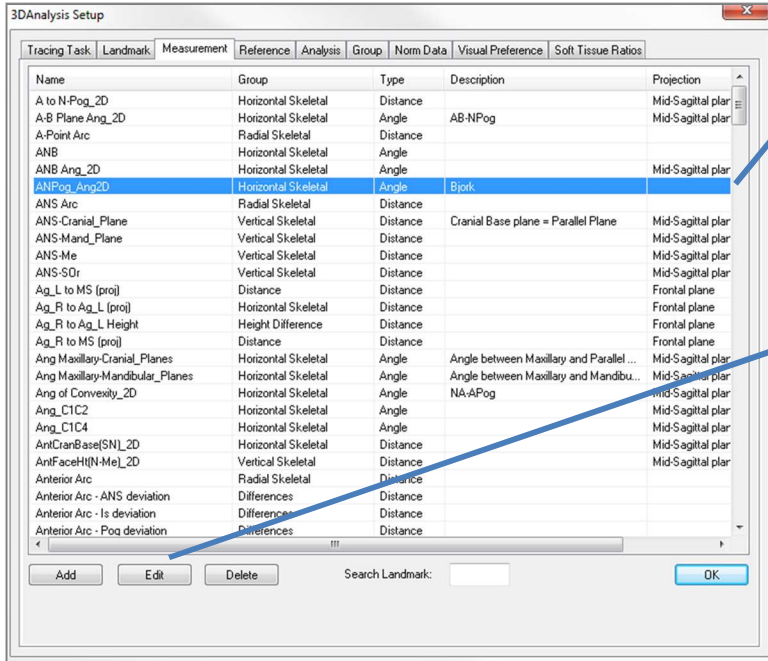

1. Left-click on the line of a measurement you want to configure.

2. Click Edit.

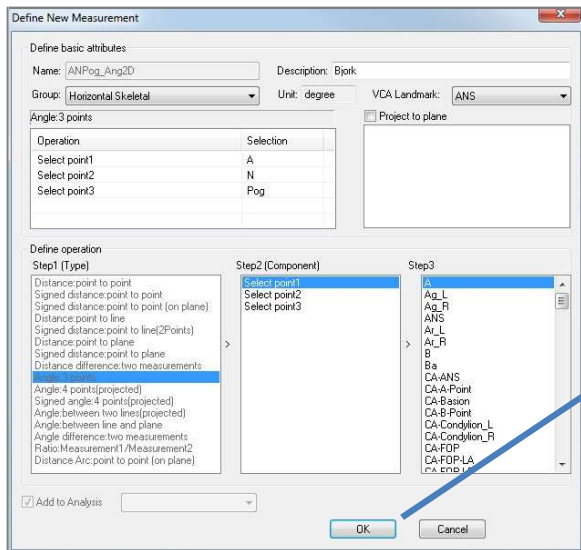

3. Click drop-down next to VCA Landmark; choose a landmark (does not have to be part of the measurement definition).

4. Click OK to exit the window. Repeat for additional measurements. (Note: Multiple measurements cannot be configured to the same VCA landmark.)

Trace the Case/Turn on VCA Landmark Visibility:

Trace the case so that the necessary landmarks are completed for the analysis as well as for the VCA landmarks. Alternatively, a pre-traced case can be opened.

Click the analysis name to show ALL VCA Landmarks within that analysis.

Click the subgroup name to show only VCA landmarks within that subgroup.

Default_VCA				Caucasian		Off
Skeletal - Sagittal	Value	Norm	SD			
SNA Ang_2D	85.83	80.80	3.90			
SNPog Ang_2D	85.58	79.00	3.00			
SNB Ang_2D	82.55	80.00	4.00			
ANB Ang_2D	3.28	2.80	2.30			
ANPog Ang2D	0.25	2.00	2.50			
Dento Alveolar - Sagittal	Value	Norm	SD			
Overjet_2D	3.49	2.50	2.50			
CL-ML Ang_2D	65.01	70.00	6.00			

If the VCA landmarks fail to appear, causes may be:

- The analysis name is not properly configured. (See pg. 157)
- The VCA landmarks configured to the measurements are not properly configured or traced. (See pg. 156)
- There is no available norm data for the measurement.

Additional VCA Settings ( Visual Preferences ) :

- VCA indicator color settings are tethered to the Wigglegram Polygon Color. Change the settings for the colored wigglegram to change the color of VCA indicators.
- VCA indicator ball radius can be set to between 2 and 9 mm.
- VCA indicator ball opacity can be changed to an opacity percentage preset (0, 25, 50, 75, 100).

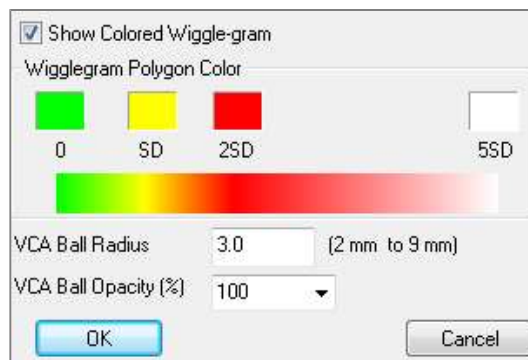

## 3DAnalysis: Advanced Analysis Configurations

3DAnalysis can be configured to become a more effective tool for certain analyses. Currently, additional features are supported for “frontal” analyses as well as the Sassouni Analysis.

### Configuring a Frontal Analysis

The wigglegram features a special “Frontal Analysis” mode to support frontal analyses. The benefit of this mode is a more succinct format of measurement presentation. Both the measurement values and wigglegram adapt to show the left and right values of a certain measurement on the same line.

Two Aspects to Configure:

- Measurement pairs that are identical except for a “\_R” or “\_L” to indicate the left and right side (ex. Co\_R to MSP, Co\_L to MSP)
- The analysis name must end in “\_Frontal”.

NOTE: A frontal analysis can only contain pairs of symmetry measurements (\_L, \_R). If your analysis contains measurement pairs AND singular measurements, you must split the analysis. The singular measurements should be in a separate analysis without the “\_Frontal” suffix.

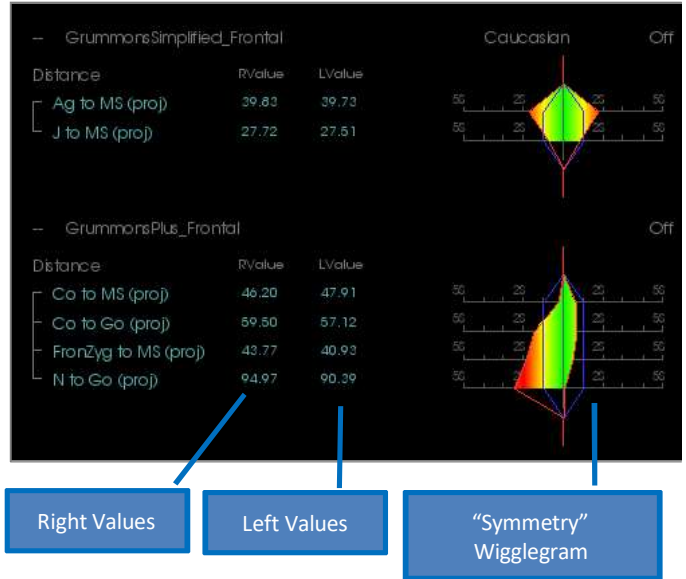

### Configuring a Sassouni Analysis

A special feature exists that creates an automatic Sassouni O-Point if the appropriate data is present. The O-Point definition is based on the generally accepted Sassouni principle that states it is the midpoint of the shortest vertical line segment that contacts all four prerequisite planes.

To Automatically Generate O-Point: The following four default planes must be traced: Parallel, Mandibular, Maxillary, and Occlusal Plane R. After tracing these planes, open/close to refresh the Create Tracing window to activate the O-Point. The Sassouni O-Point is a 2<sup>nd</sup> Tier landmark.

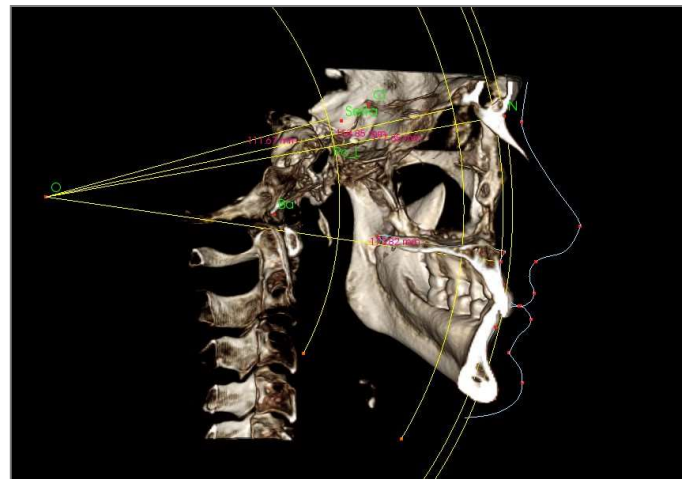

NOTE: The Parallel Plane requires the Supraorbitale Plane to be defined. The following Sassouni-specific landmarks are therefore required: Si, RO, Cl.

### 3DAnalysis: Create Face Photo

3DAnalysis allows the user to wrap a common digital photograph over the patient’s soft tissue. This creates a realistic 3D “skin” that takes the texture of the photograph and can be used to great effect in performing soft tissue simulations and patient demonstrations. The steps to creating a face photo wrap are as follows:

Click the  Create Face Photo to open the dialog. There are two methods available.

Generate face from photo:

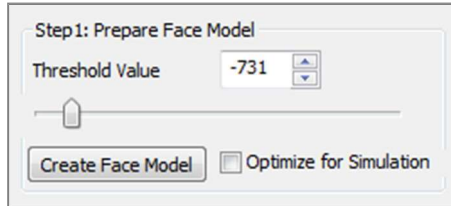
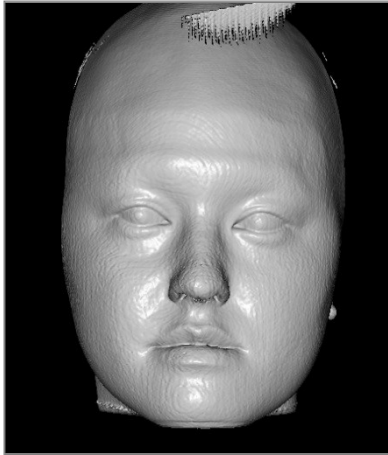

The objective is to move the slider until a smooth soft tissue frontal profile is visible. This setting will determine what level of tissue is used when creating the face model. Click Create Face Model when the correct setting is found. The face model will be created and automatically smoothed.

“Optimize for Simulation”: When checked, the software will automatically reduce the number of triangles used in the model to 40,000. This is the optimal setting for soft tissue simulations.

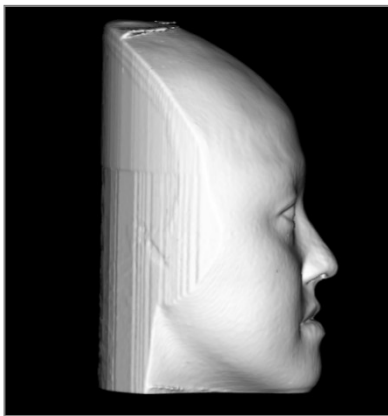

Click Apply Cutting. Use three cuts to trim away unnecessary parts of the face (that may cause distortion when the photo is applied). The first will cut through the face coronally just in front of the ear. The second will cut along the jaw line, making sure the cutting plane aligns with the mandibular plane. The third will cut axially across the top of the skull. Use the arrows to move the cutting plane and click the right mouse button to perform the cut. Click Finish Cutting when all unnecessary sections have been removed.

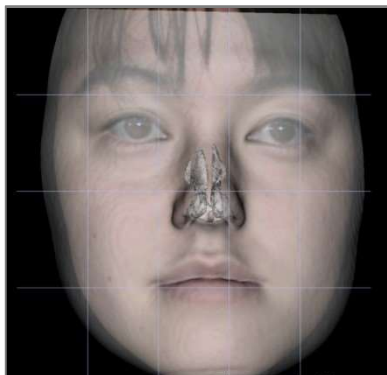

Click Load Photo and choose the appropriate photo from the file browser. Check to turn on “Make Face Model Transparent” and “Show Registration Grid” (intersections indicate registration points) and use image navigation shortcuts to align the photo, taking special care in the lip and nose regions. Click Apply Photo Wrapping when the correct alignment is found.



Load Face (.obj):



Step1: Load object and image files

Load Scan

Load the 3D object file and the corresponding texture file.

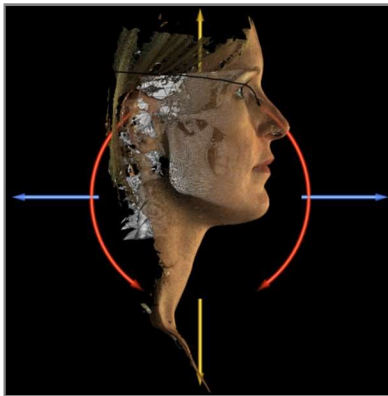

Step2: Model Alignment

Threshold Value 500

Manual Alignment

Automatic Alignment

Pick Points on loaded model:

- Brow middle (Soft N)
- Nose tip (Prn)
- Chin tip (Soft Pg)

The textured skin model can now be aligned to the volume either manually using the widget tool or automatically if the soft tissue profiles of the case have been traced. The automatic alignment process involves placing landmarks onto the textured skin model.

## 3DAnalysis: Landmark-Based Superimposition

A superimposition can be performed on the current tracing using any saved tracing (.inv or .ctr) file and user-configured landmarks. This feature combines the visual analysis aspect of volume superimposition with the quantitative details provided by a cephalometric analysis.

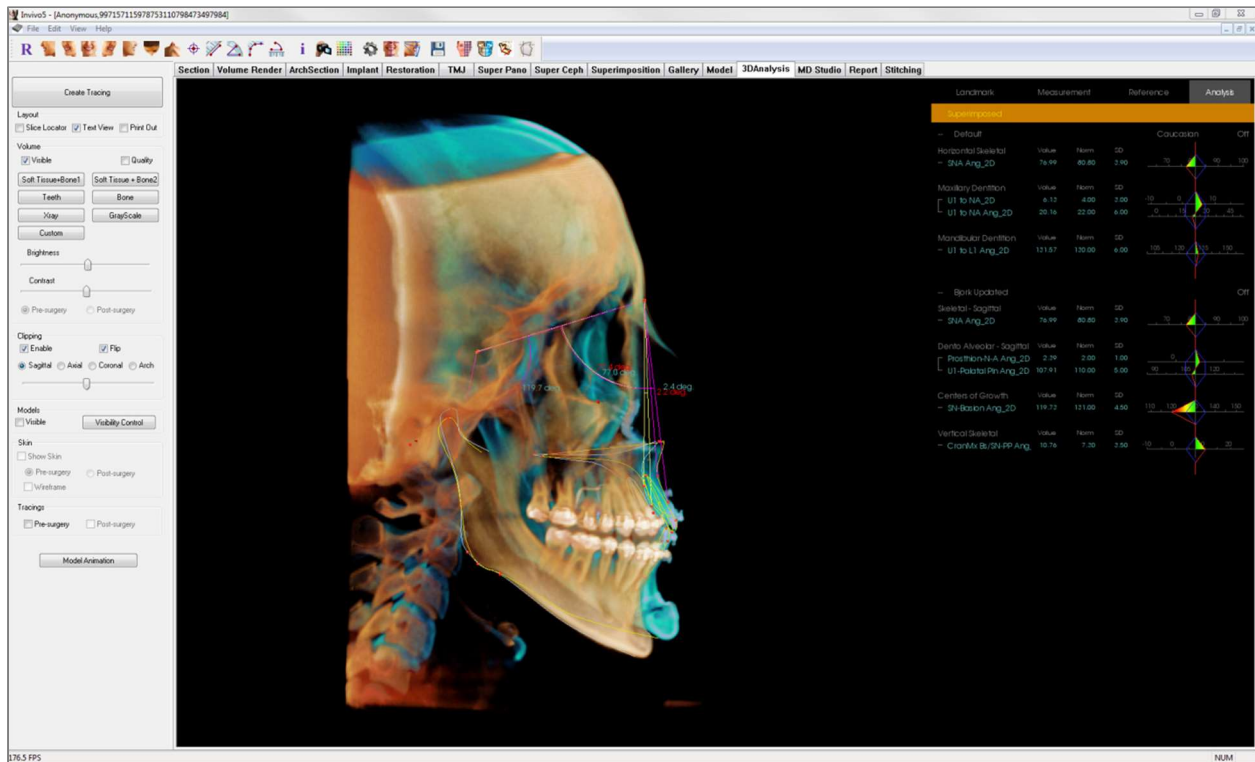

### Features:

- View measurements from both volumes in the same window with easy toggle switching
- Visibility On/Off for superimposed volume, tracing, or data
- Automatic superimposition of volumes after one-time landmark configuration setup
- Allows for a template-based analysis (with superimposed saved tracing)
- Compatibility with VCA and frontal configurations
- Orientation synchronization with the Superimposition Tab

## Performing Landmark-Based Superimposition

Click the  Superimpose Tracing icon to open the dialog.

After tracing a case in 3DAnalysis, the user can select another traced case (.inv) or tracing file (.ctr) to superimpose over the original.

- Click Select Traced Case... to browse for the file. Select the case or saved tracing and click Open to close the browser. If an untraced case is chosen, an error will appear indicating that there is no tracing data.
- Click Configure... to open the Configure Landmark Superimposition window:

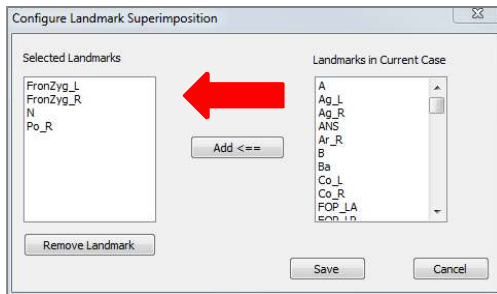

- Select a minimum of four landmarks from the current landmark list and click Add to move them to the left. Landmarks on the left will be checked with the superimposed tracing. If they have been traced, these landmarks will be used to register the two scans. Click Remove Landmark to remove landmarks if you are editing your saved configuration. Click Save to Exit.
- Verify the available landmarks. If the configured landmarks do not appear in this section, there is no tracing data available for those landmarks in the selected case.
- Click Perform Superimposition And Exit to perform the registration with the current configuration. This window will automatically close.
- Revisit this window to perform superimposition with another case (deleting the current superimposition), reconfigure the superimposition landmarks, and to toggle the following visibility options (“Superimposed Volume,” “Superimposed Tracing,” and “Superimposed Data”).

Tip: For performing a template-based analysis, the user can superimpose the saved tracing template to the patient scan using mid-sagittal plane landmarks.

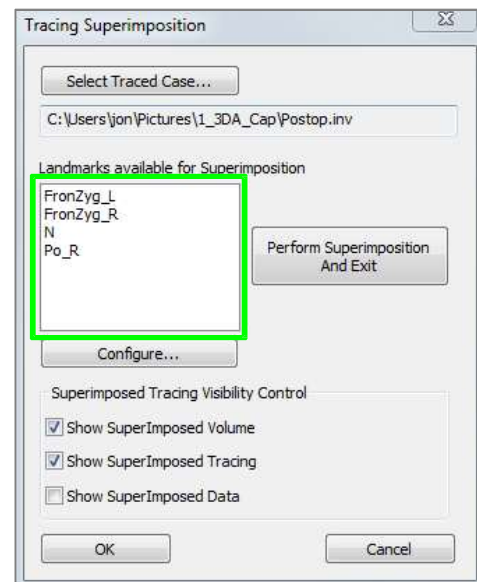
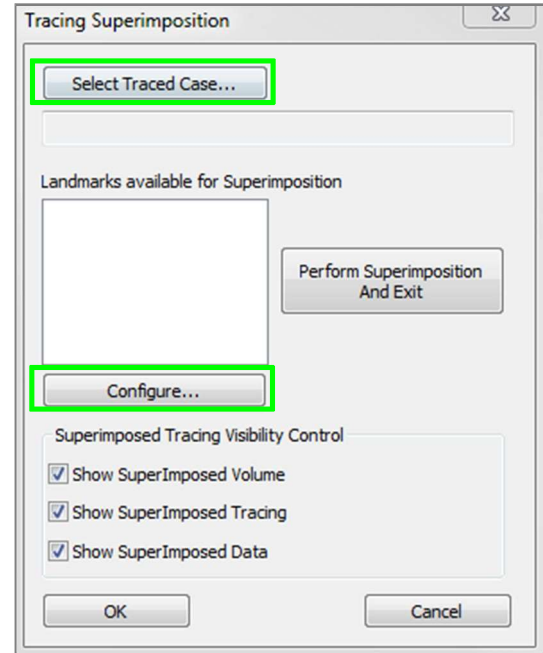

### Superimposition Text View

After a superimposition has been performed with a traced case, the Text View can be toggled to show either the tracing/analysis data for the current or superimposed case.

The Text View can be toggled by:

- Checking/unchecking the box next to “Show SuperImposed Data” in the Superimpose Tracing dialog.
- Clicking the “Superimposed” or ”Default Tracings” banner above the text data to toggle data sets.
- Pressing “s” on the keyboard.

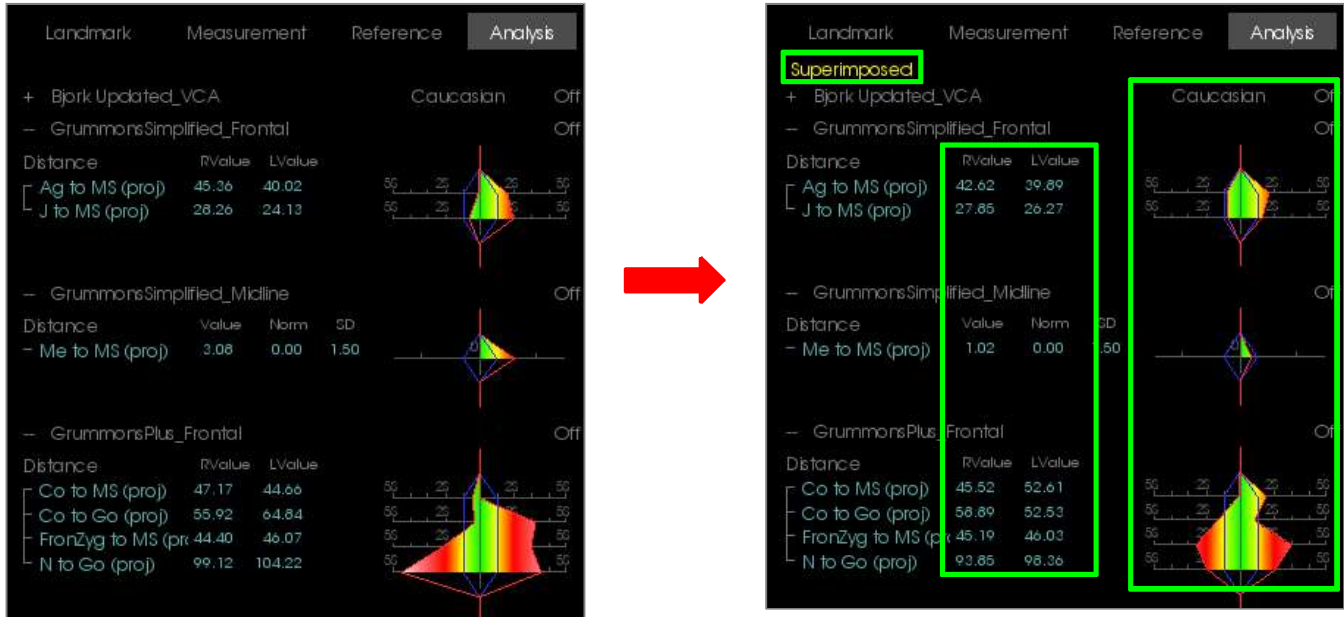

The yellow “Superimposed” text indicates which data set the Text View is currently displaying. If the superimposed tracing contains at least the same amount of corresponding data as the current, differences will only be seen in the measurement value section and the colored wigglegram, allowing the user to easily compare the two sets of data.

If toggling reveals a discrepancy in the available measurements, landmarks, or references, then check to make sure that the two cases contain the same traced landmarks and profiles.

Visual preferences are locked for the superimposed case – only the visual preferences for the current case can be changed. Alter these settings to help differentiate between the two data sets, such as angle and line color. Superimposed tracing color will be yellow by default.

## How Does 3DAnalysis Work with the Superimposition Tab?

3DAnalysis landmark-based superimposition and Import Volume within the Superimposition Tab achieve the same basic purpose with some differences only in the available tools and method of superimposition. The compatibility of the two methods of superimposition will be explained below.

Only one superimposition can be supported at a time

- Users can either choose to import a saved tracing using the Import New Volume function of Superimposition tab or the Superimpose tracing function of 3DAnalysis. The volume will be visible in both views, with additional tracing data visible in 3DAnalysis if it exists.
- Trying to superimpose an additional case in either tab with a superimposition already performed will overwrite the currently superimposed case. Mirror Own Volume will also overwrite the current superimposition.
- Changes in orientation performed in one tab will affect the other tab. The benefit of this is that a user can superimpose to landmarks in 3DAnalysis and then move to the Superimposition tab and perform an additional volume-based registration to fine-tune the location of the superimposition.

The following settings must be performed in the Superimposition Tab (to take effect in 3DA):

- Clipping
- Volume rendering presets
- Brightness and contrast settings
- Volume Registration
- Adjustments by Move Widget

The following settings overlap between the two tabs:

- Superimposed volume on/off
- Landmark registration (in 3DA, this is performed automatically with preconfigured landmarks)

### 3DAnalysis: Layout Options

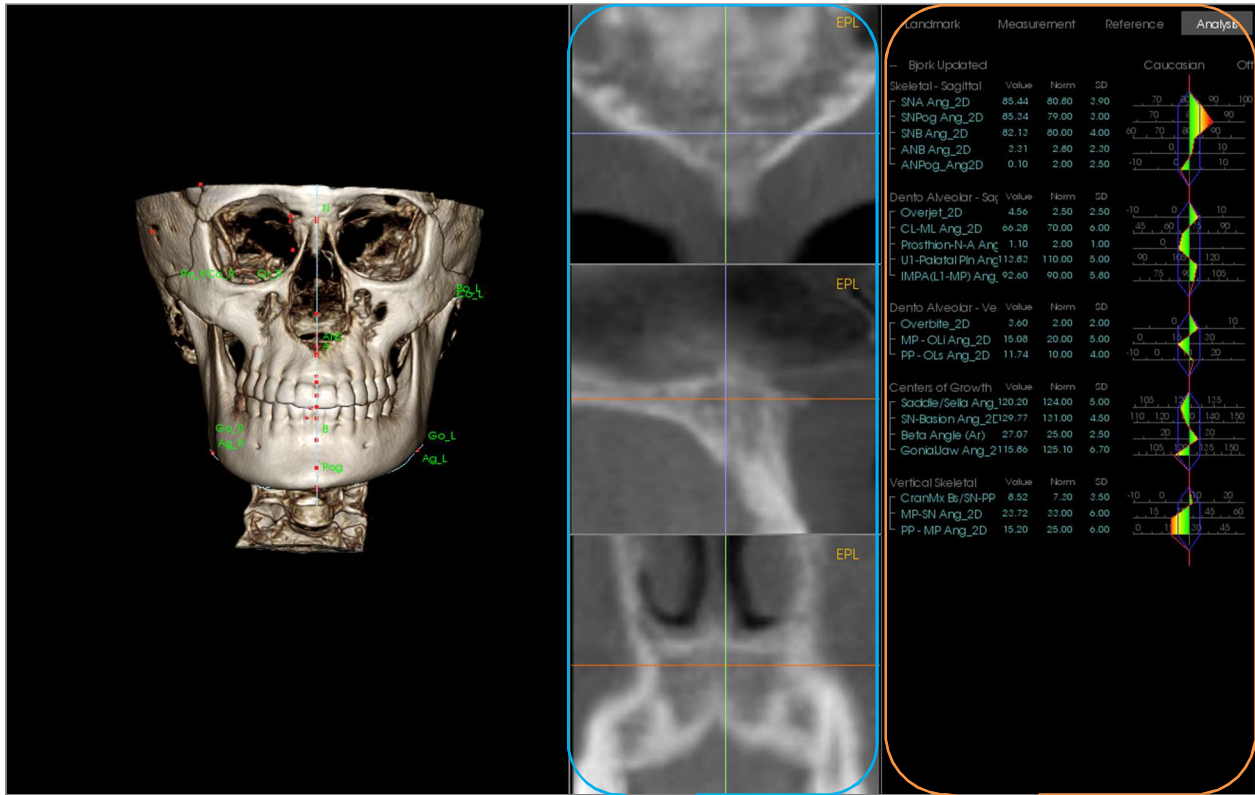

Slice Locator      Text View

**Slice Locator:** This three-paned window allows the user to adjust the placement of points using multiple viewing angles of the same location: axial, coronal, and sagittal. This tool is important for placing landmarks that require increased accuracy, such as the top of the condyle head. The panes are zoomed-in to provide additional accuracy.

**Text View:** Contains visibility controls and values for landmarks, measurements, reference planes, and analysis configurations.

**Print Layout:** This layout loads preconfigured visibility options that are printer-friendly so the user can easily share or save a physical copy of the analysis results. In this layout mode, printing will automatically occur with the volume in life-size.

*Zoom-in and zoom-out features will be disabled to maintain a life-sized volume, and all text and tracing will be black by default. Both the volume and colored wigglegram will maintain color unless configured differently.*

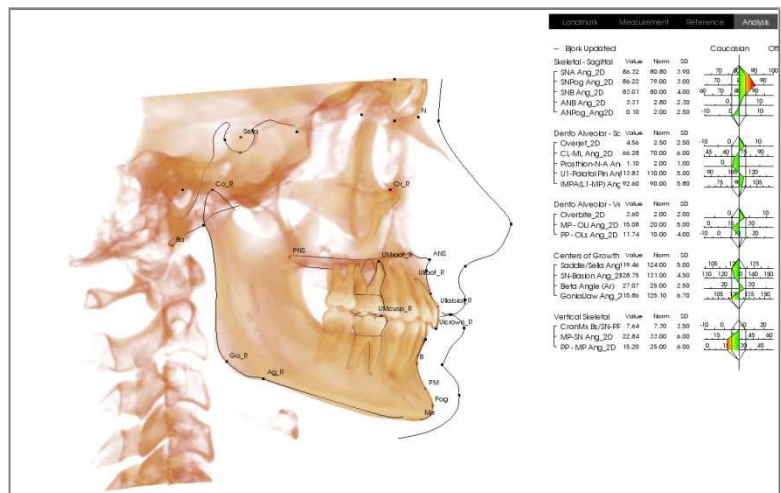

Print Out View

## 3DAnalysis: 3DAnalysis Settings



Press the 3DAnalysis Settings icon and a window will appear allowing you to create and/or define any of the following:

- Tracing Tasks
- Landmarks
- Measurements
- References (Lines, Planes)
- Analyses
- Groups
- Population Norm Data
- Visual Preference
- Soft Tissue Ratios

Tracing Task: This tab shows the definition list of current tracing task series. The tracing task will be performed in the order displayed on this list. To change the tracing task order, press the Edit button in the bottom left corner of the window. According to the definition of coordinate system, the appropriate coordinate system defining tasks will always be the starting tasks and added automatically.

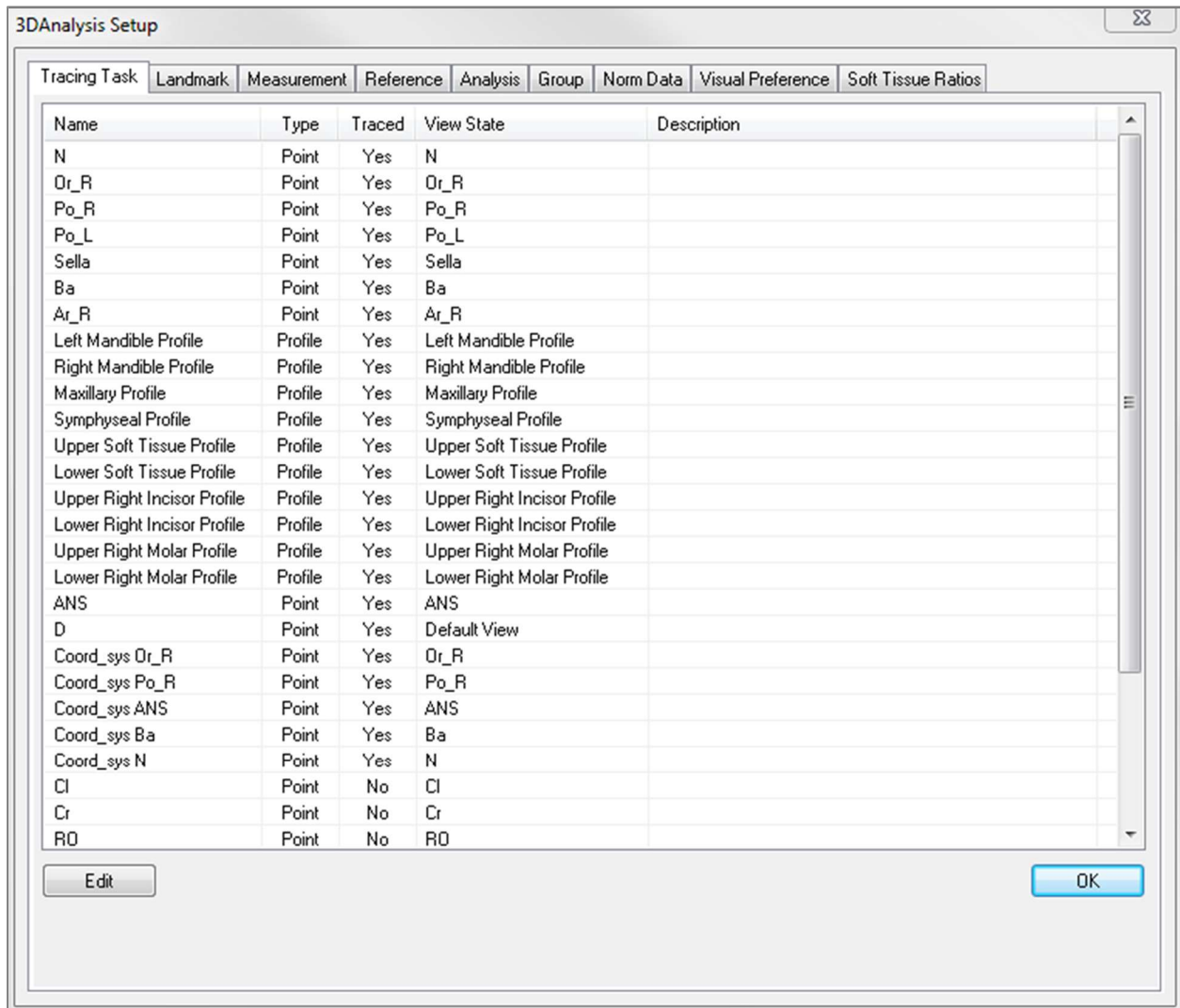

- Edit: Opens “Tracing Guide” dialog to edit the tracing task list or adjust the view states for individual tracing tasks. For more information, refer to 3DAnalysis: Tracing Guide (pg. 178).



Landmark: This tab shows the definition list of all available landmarks that can be used for defining measurements and references. Each landmark has a unique name and will be displayed in every view within the Rendering Window. Landmarks have a group definition for sorting when Text View is activated. You can add user-defined landmarks, marked with a star (\*) in column 'U.' Predefined landmarks cannot be deleted. User-defined landmarks cannot be deleted when used by other measurements or references.

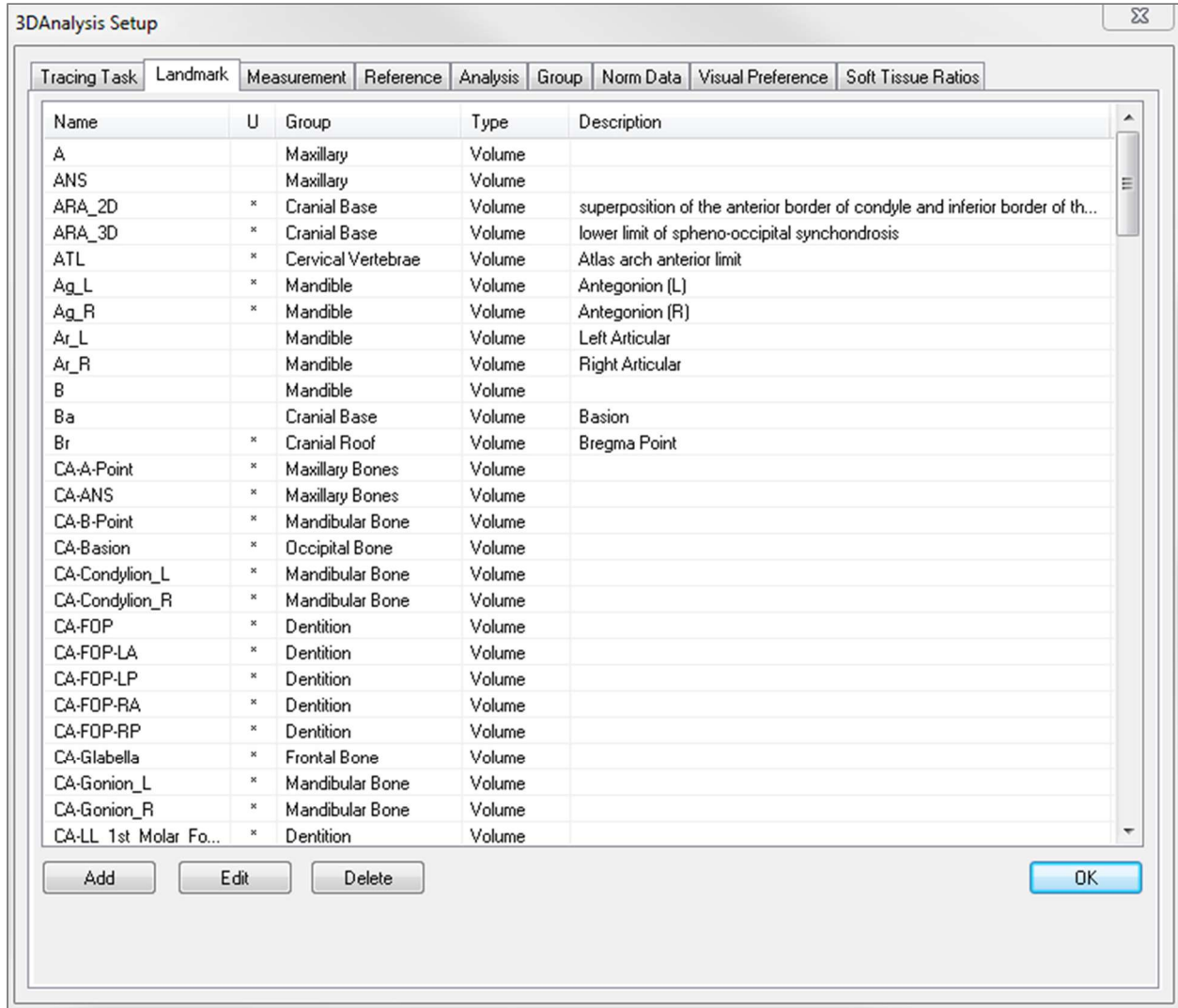

- Add: Create a new landmark
- Edit: Edit currently selected landmark
- Delete: Delete currently selected user-defined landmark

### Special Landmark Properties

Underneath the group list, there are two landmark properties that can be modified using the adjacent checkboxes:

#### On Mid-Sagittal Plane

Projects a landmark on any part of the volume directly to the defined mid-sagittal plane. Cannot be used to define the coordinate system.

#### Midpoint

Automatically creates a midpoint between two landmarks when both are traced; there will be no tracing task option. Clicking the checkbox will bring up a Define 2<sup>nd</sup> Tier landmark submenu with two drop-down boxes for selecting the landmarks. 2<sup>nd</sup> Tier indicates that the placement of the landmark is dependent on the placement of other landmarks. Can be used to define the coordinate system.

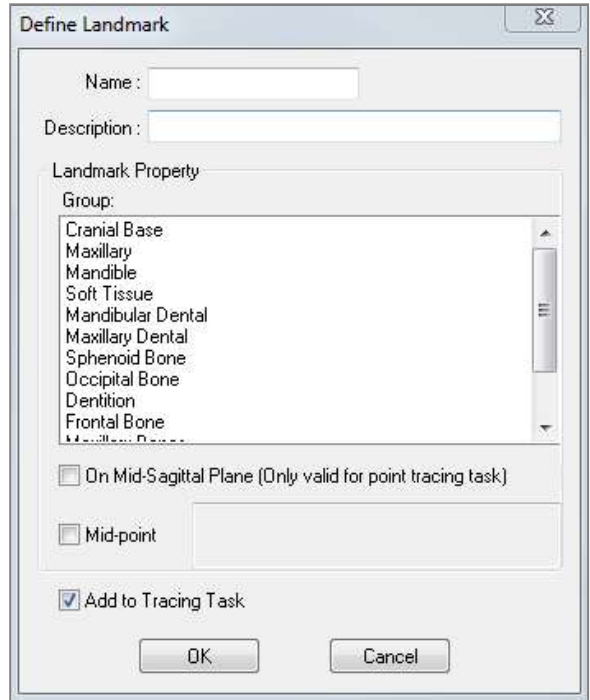

Measurement: This tab shows the definition list of all available measurements. Every measurement has a unique name and will be displayed in every view within the rendering window. Measurements have a group definition for sorting when Text View is activated. Measurements can be defined in several ways using default and/or user-defined landmarks, reference lines, and reference planes. Measurements can be in 3D or projected to a specified reference plane for supporting 2D measurements. Measurements cannot be deleted when used in an analysis.

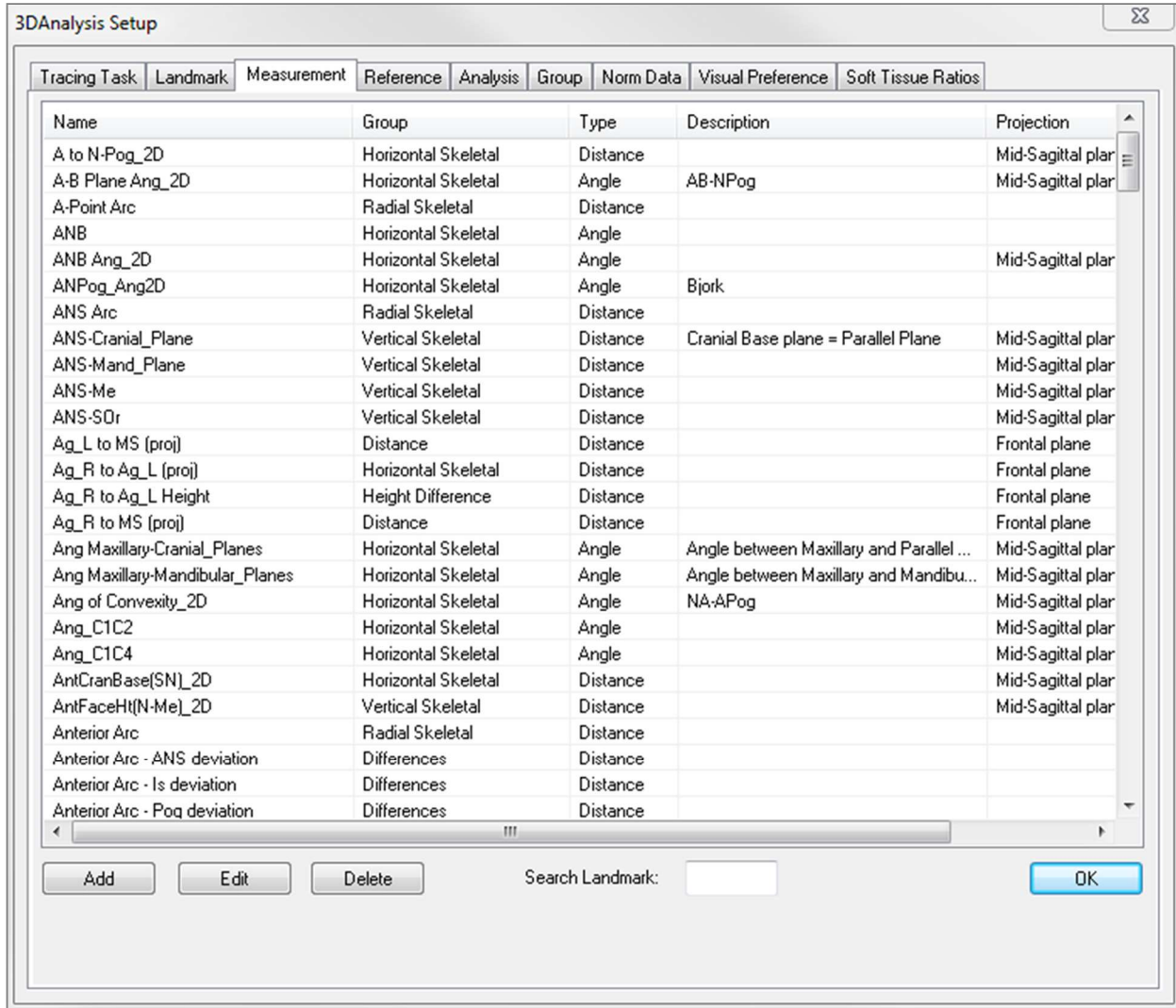

- Add: Create a new measurement.
- Edit: Edit currently selected measurement.
- Delete: Delete currently selected measurement.
- Search Landmark: Search for measurements by landmark.

Reference: This tab shows the definition list of all available references. Every reference has a unique name and will be displayed in every view within the rendering window. References have a group definition for sorting when Text View is activated. Reference lines and reference planes can be defined in several ways using landmarks and/or other reference lines and planes. References cannot be deleted when used to define other measurements, references or the coordinate system (ex: mid-sagittal plane and frontal plane).

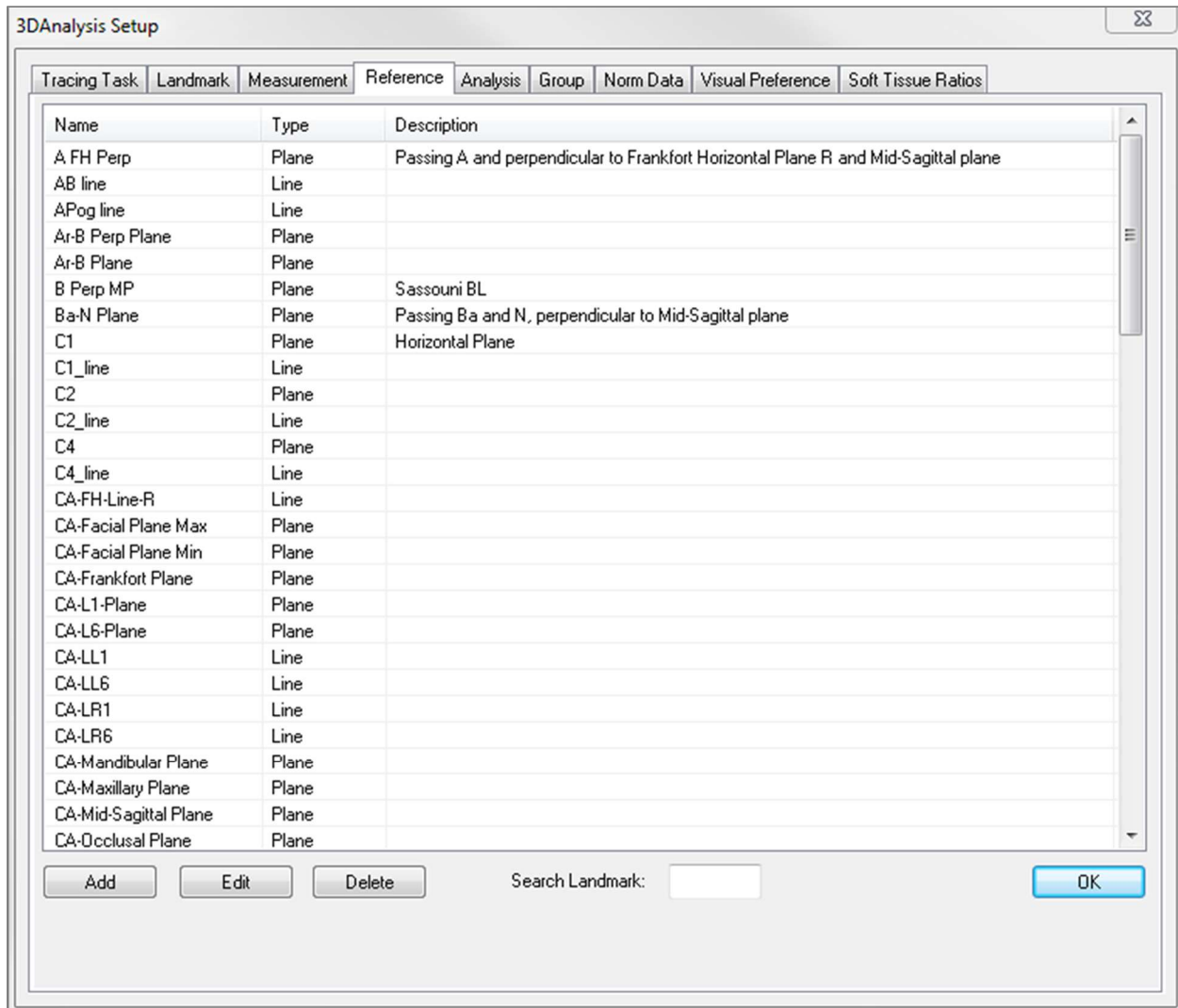

- Add: Create a new reference line or reference plane.
- Edit: Edit currently selected reference.
- Delete: Delete currently selected reference.
- Search Landmark: Search for references by landmark.

Analysis: This tab shows the definition list of all available analyses. Analyses include existing 2D analysis standards (ex: McNamara, Ricketts, Steiner). You can also create your own analysis using default and/or user-defined measurements. Only checked analyses will be reported within the Text View and only default analyses can be compared to existing data using norm data (compared visually using wigglegram). User-defined analyses can be compared to existing data if the data is added manually (see the Norm Data section, pg. 175).

The tracing tasks required for all of the measurements of the selected analysis are displayed under Required Landmarks but may need to be manually added into the Tracing Tasks list (see 3DAnalysis: Tracing Guide, pg. 178).

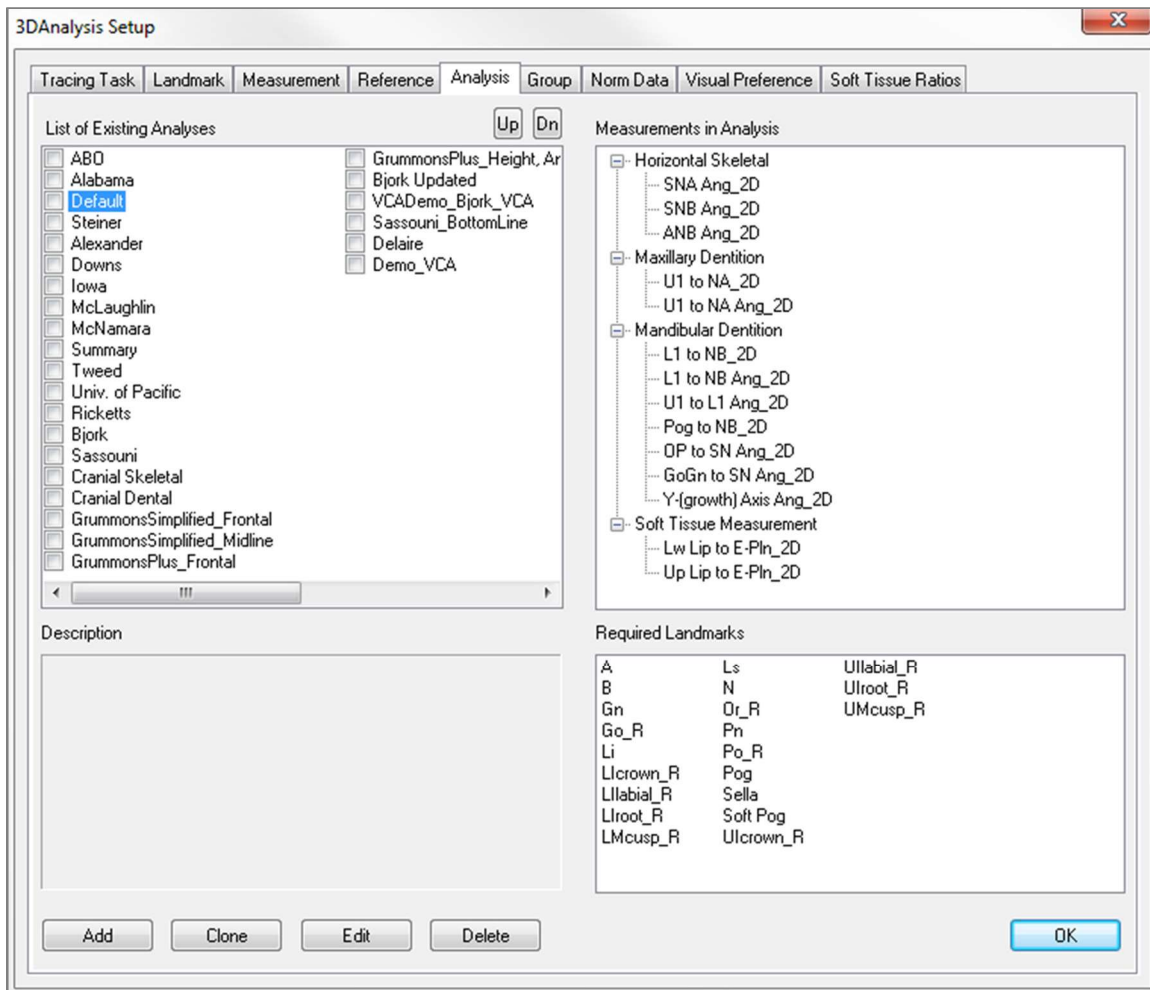

- Add: Create a new analysis.
- Clone: Make a copy of the currently selected analysis.
- Edit: Edit currently selected analysis.
- Delete: Delete currently selected analysis.

Group: This tab shows the definition list of all available groups used for landmarks, measurements, and norm data. By default, four predefined user Norm Data Groups (My African American, My Asian, My Caucasian and My Latin) are automatically generated within the definition list. A user-defined Norm Data Group can reference an external norm data file or CSV file. This file can be an accumulated measurement archive file.

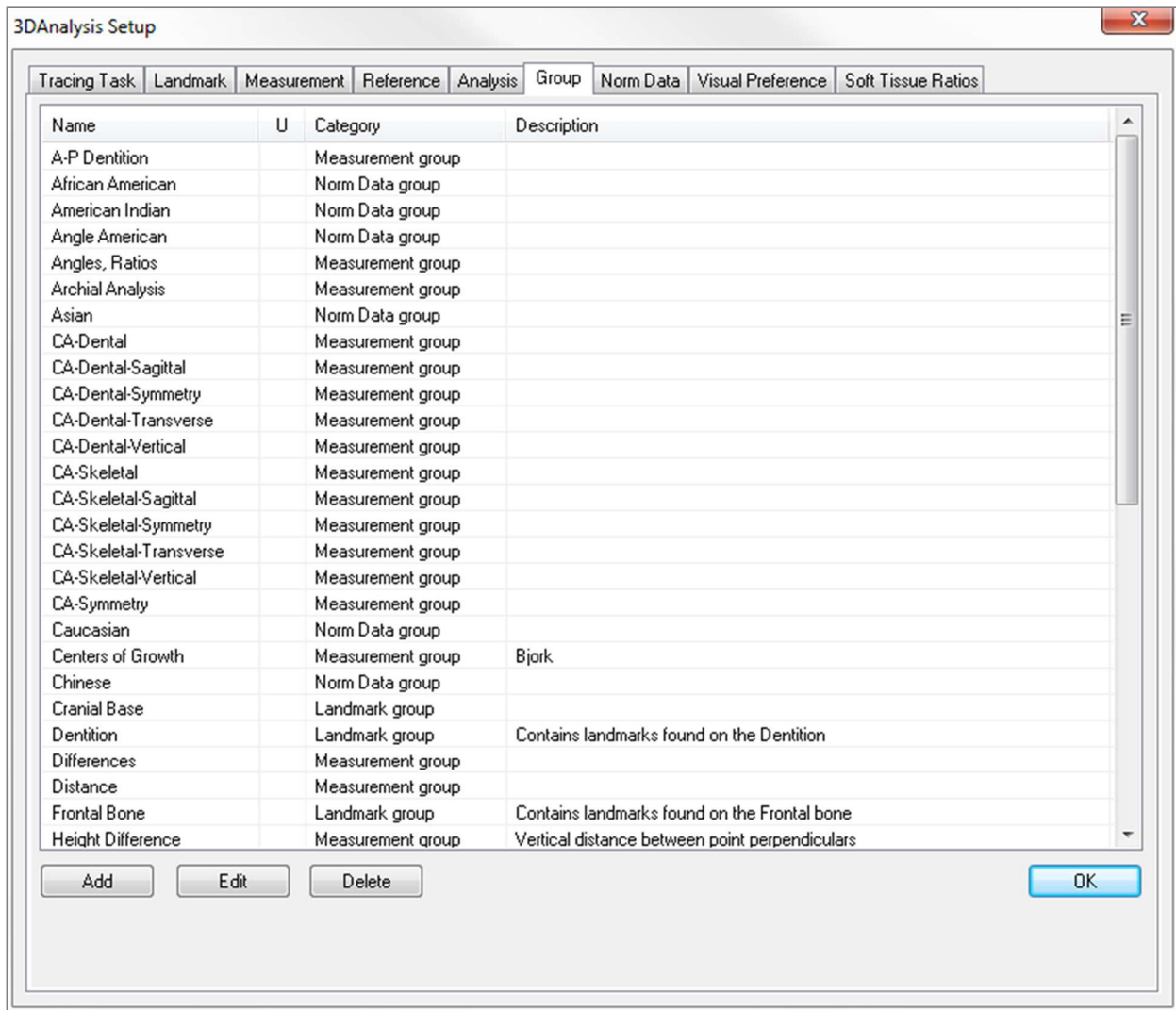

- Add: Create a new group.
- Edit: Edit currently selected group.
- Delete: Delete currently selected group.

Norm Data: This tab shows the norm data (mean and standard deviation of measurements) list of all available ethnic Norm Data Groups that can be used for analysis and displayed graphically using the wigglegram. The norm data can be changed at any time in 3DAnalysis so you can compare the patient's tracings with data from several ethnic groups. The default Norm Data Group is Caucasian, but 3DAnalysis includes norm data for other well-known ethnic groups. Custom Norm Data Groups can be defined using external norm data files (see Group section, pg. 174). The mean and standard deviation of new measurements can also be defined manually within the Norm Data tab.

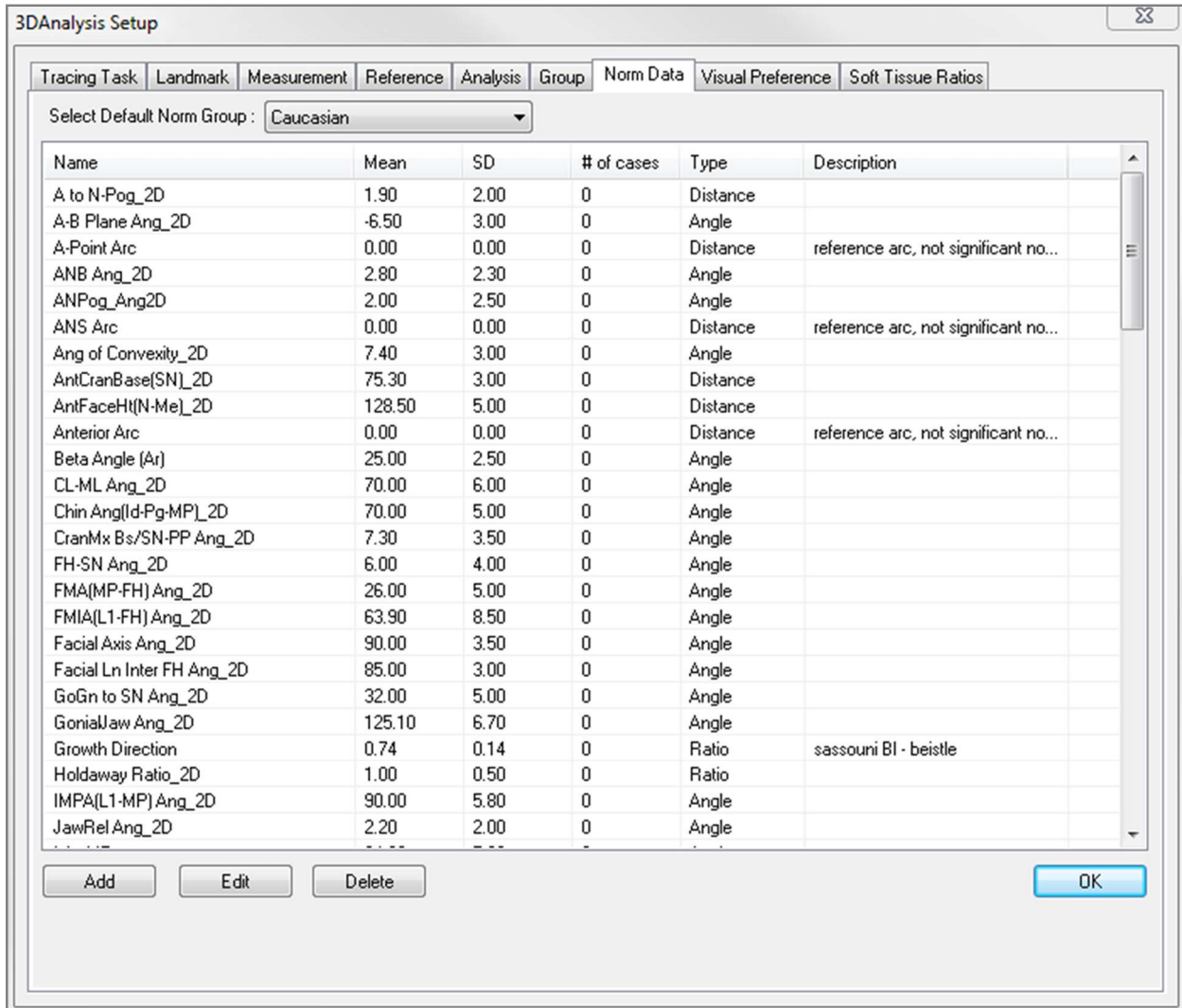

- Add: Create a new norm data.
- Edit: Edit currently selected norm data.
- Delete: Delete currently selected norm data.

Visual Preference: This tab allows you to change the colors and attributes of 3DAnalysis objects and select color usage for Print Layout. Select Projection can select projection type of light source from volume object with parallel projection set by default. When “Use Foreground Color” is unchecked, all 3DAnalysis objects (landmarks, measurements, references, etc.) will be displayed in color on Print Layout.

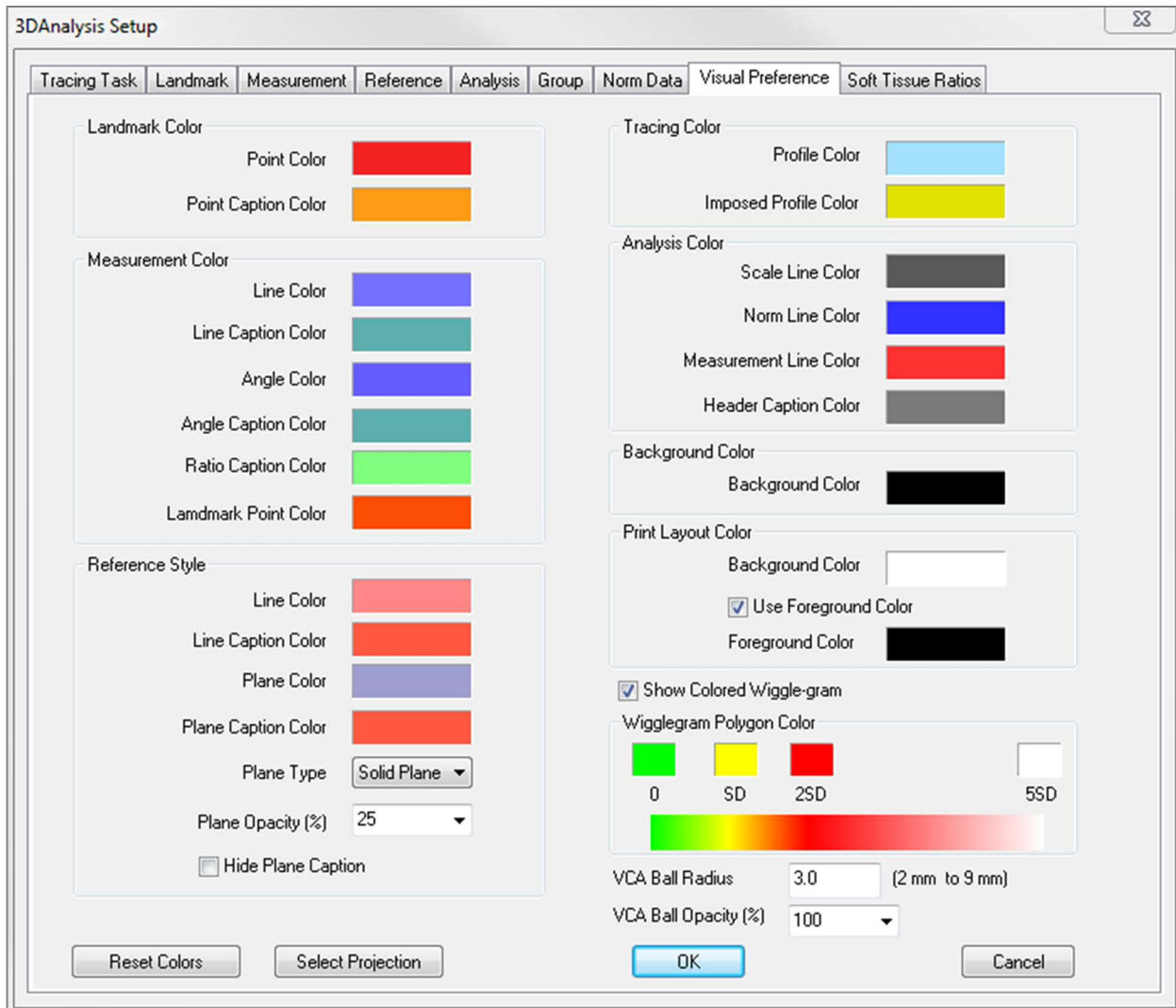



Soft Tissue Ratios: This tab allows you to change the soft tissue deformation ratios across different axes for 3D Surgery manipulations. Checking “R-L Matches A-P” will match the R-L values to the A-P values of the respective landmarks automatically. Reset to Defaults will revert the values to the ones shown below.

3DAnalysis Setup

Tracing Task | Landmark | Measurement | Reference | Analysis | Group | Norm Data | Visual Preference | Soft Tissue Ratios

Soft Tissue Deformation Ratios

	A-P	R-L	S-I
Pn	0.35	0.35	0.1
Ls	0.6	0.6	0.2
Sts	0.6	0.6	0.2
Sti	0.65	0.65	0.65
Li	0.65	0.65	0.65
Soft Pog	0.9	0.9	0.5

R-L Matches A-P     



Warning: Soft tissue prediction is an approximation and may not reflect actual results.

## 3DAnalysis: Tracing Guide

To open the Tracing Guide window, press either the Setup button from the Tracing Tasks window or Edit from the Tracing Tasks tab within Settings.

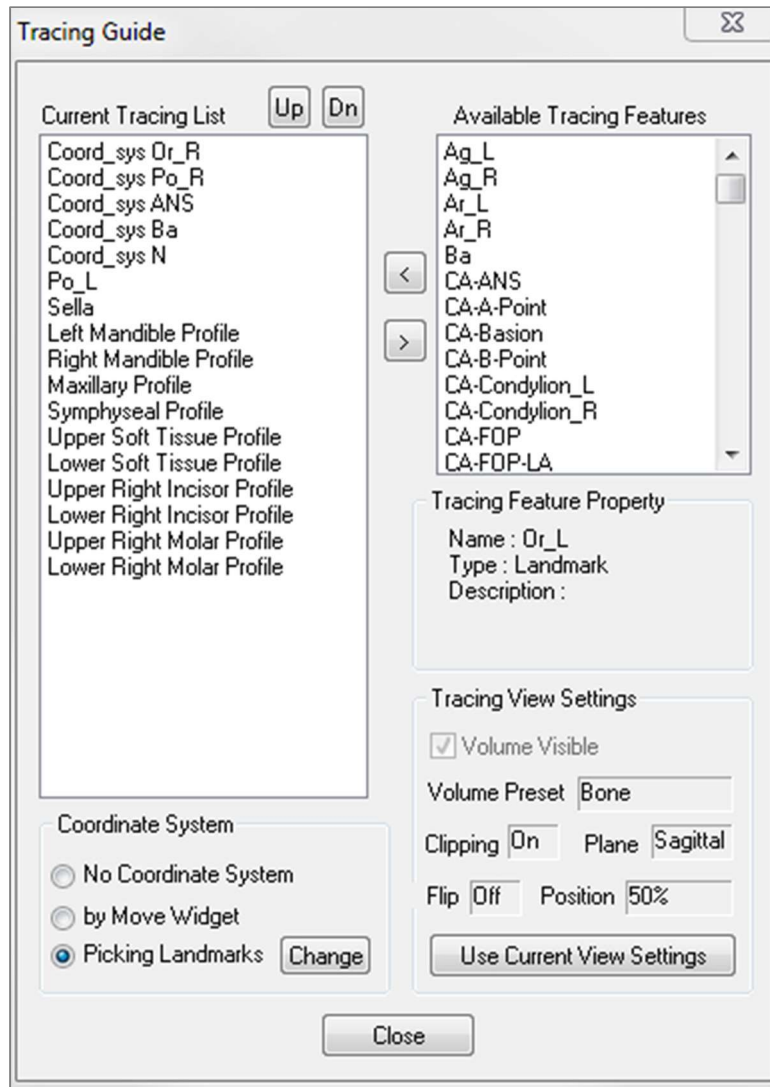

Tracing Guide: The Tracing Guide window shows a list of the current Tracing Tasks (left list box) and a list of available Tracing Features (right list box). Within the window, you can add, move, or reorder Tracing Tasks, change the coordinate system and record the best view settings for specific Tracing Tasks.

- <: Add the highlighted Available Tracing Feature to the Current Tracing List. All available landmark definitions and predefined profile Tracing Tasks currently not in use are listed in Available Tracing Features box.
- >: Remove the highlighted tracing task from the Current Tracing List. Coordinate system tracing tasks and respective landmarks cannot be removed.
- Up: Change order to move up that selected tracing task. Tracing tasks near the top of the list take priority when creating tracings. Tracing tasks do not take priority over coordinate system tracing tasks and so cannot move above coordinate system tracing tasks.
- Dn: Change order to move down that selected tracing task. Coordinate system tracing tasks cannot move below normal tracing tasks.

- Coordinate system change: You can change coordinate system definition by selecting either “No Coordinate System,” “by Moving Widget,” or “Picking Landmarks.” Select Change to change which landmarks will define the coordinate system. (See 3DAnalysis: Coordinate System, pg. 141.)
- Use Current View Settings: You can change the default view state of a tracing task. Highlight a tracing task under the “Current Tracing List.” Set the Rendering Window to a preferred view by adjusting the brightness, volume visibility (if tracing on models for certain tasks), orientation, clipping, etc. (relative to the current patient coordinate System). Press Use Current View Settings to save the current view state. During your tracing, the highlighted tracing task will automatically set itself to the saved view state.

Note: Before adding the frontal incisor profiles to the current tracing task list, you must first ensure that the lateral profiles are no longer on the list.. The two types of incisor profiles are not intended to be used simultaneously.

## 3DAnalysis: Default Tracing Tasks and Landmarks

Name	Definition	Description
A	A-Point	Deepest midline point on the premaxilla between the anterior nasal spine and prosthion. Point is determined within the software from the maxillary profile.
Ag_L	Left Antegonion	Highest point of the concavity of the lower border of the ramus where it joins the body of the mandible (left side). Point is determined within the software from the left mandibular profile.
Ag_R	Right Antegonion	Highest point of the concavity of the lower border of the ramus where it joins the body of the mandible (right side). Point is determined within the software from the right mandibular profile.
ANS	Anterior Nasal Spine	Anterior point of nasal spine defined by the maxillary profile.
B	B-Point	Deepest midline point on the mandible between infradentale and pogonion. Point is determined within the software from the symphyseal profile.
Ba	Basion	Anterior point of foramen magnum.
Co_L	Left Condyle	Most posterior superior point on the condyle of the mandible (left side). Point is determined within the software from the mandibular profile.
Co_R	Right Condyle	Most posterior-superior point on the condyle of the mandible (right side). Point is determined within the software from the mandibular profile.
Coord_sys ...	Coordinate System Defining Point	The landmark (preceded with "Coord_sys") will be used to define the coordinate system for subsequent landmarks and tracing tasks.
Custom Profile	Custom Profile	Using points with connecting lines, a custom profile can be made to highlight a certain anatomical feature.
Gn	Gnathion	Point on chin between the menton and pogonion. Point is determined within the software from the symphyseal profile.
Go_L	Left Gonion	Most outward point on the angle formed by the junction of the ramus and the body of the mandible (left side). Point is determined within the software from the mandibular profile.
Go_R	Right Gonion	Most outward point on the angle formed by the junction of the ramus and the body of the mandible (right side). Point is determined within the software from the mandibular profile.
Id	Infradentale	Point of transition from the crown of the most prominent mandibular medial incisor to the alveolar projection. Point is determined within the software from the mandibular profile.
Ils	Soft-tissue B Point	Deepest midline point on the mandible between the infradentale and the pogonion projected onto the soft tissue. Point is determined within the software from the lower soft tissue profile.
Left Mandibular Profile	Left Mandibular Profile	Trace the left-side mandibular profile with a series of points (double-click or right-click to finish tracing). Include the coronoid process, mandibular notch, condyle, and ramus profiles.
Li	Labrale Inferius	Most anterior point of lower lip. Point is determined within the software from the lower soft tissue profile.
Ls	Labrale Superius	Most anterior point of upper lip. Point is determined within the software from the lower soft tissue profile.

Lower Left Incisor Profile	Lower Left Incisor Profile	Define the profile of the lower left incisor using 3 points: 1. Root of lower incisor (LIroot_L) 2. Crown of lower incisor (LIcrown_L) 3. Labial point of lower incisor (LIlabial_L)
Lower Left Molar Profile	Lower Left Molar Profile	Define the profile of the lower left molar using 3 points: 1. Anterior root of lower molar (LMroot_L) 2. Anterior cusp of lower molar (LMcusp_L) 3. Posterior cusp of lower molar
Lower Right Incisor Profile	Lower Right Incisor Profile	Define the profile of the lower right incisor using 3 points: 1. Root of lower incisor (LIroot_R) 2. Crown of lower incisor (LIcrown_R) 3. Labial point of lower incisor (LIlabial_R)
Lower Right Molar Profile	Lower Right Molar Profile	Define the profile of the lower right molar using 3 points: 1. Anterior root of lower molar (LMroot_R) 2. Anterior cusp of lower molar (LMcusp_R) 3. Posterior cusp of lower molar
Lower Soft Tissue Profile	Lower Soft Tissue Profile	Trace the profile of the lower soft tissue with a series of points (double-click or right-click to finish tracing). The lower soft tissue is defined as including the lower lip.
Maxillary Profile	Maxillary Profile	Trace the profile of the maxilla with a series of points (double-click or right-click to finish tracing).
Me	Menton	Lowermost point of the mandibular symphysis. Point is determined within the software from the symphyseal profile.
N	Nasion	Central point along the nasofrontal suture.
Or_L	Left Orbitale	Bottom ridge of the orbitale on the maxilla (left side)
Or_R	Right Orbitale	Bottom ridge of the orbitale on the maxilla (right side)
PM	Protuberance Menti	Point above pogonion at top of crest of the symphysis or at the point of recess of the anterior symphyseal curvature. Point is determined within the software from the symphyseal profile.
Pn	Pronasale	Most anterior point of the nose tip. Point is determined within the software from the soft tissue profile.
PNS	Posterior Nasal Spine	Midpoint of the base of the palatine bones at the posterior margin of the hard palate. Point is determined within the software from the maxillary profile.
Po_R	Porion (right)	Upper ridge of the porion (right side)
Po_L	Porion (left)	Upper ridge of the porion (left side)
Pog	Pogonion	Most anterior point on the symphysis of the mandible. Point is determined within the software from the symphyseal profile.
Pr	Prosthion	Most anterior point of the maxillary alveolar process in the midline. Point is determined within the software from the maxillary profile.
Right Mandibular Profile	Right Mandibular Profile	Trace the right-side mandibular profile with a series of points (double-click or right-click to finish tracing). Include the coronoid process, mandibular notch, condyle, and ramus profiles.
Sella	Sella Turcica	Center of sella turcica

Soft N	Soft-tissue Nasion	Deepest point on the concavity of the soft tissue profile overlying the area of the frontonasal suture. Point is determined within the software from the soft tissue profile.
Soft Pog	Soft-tissue Pogonion	Most anterior point on the soft tissue chin in the mid-sagittal plane. Point is determined within the software from the soft tissue profile.
Sti	Stomion inferius	Most superior point located on the lower lip. Point is determined within the software from the lower soft tissue profile.
Sts	Stomion superius	Most inferior point located on the upper lip. Point is determined within the software from the upper soft tissue profile.
Symphyseal Profile	Symphyseal Profile	Trace the profile of the symphysis with a series of points (double-click or right-click to finish tracing).
Upper Left Incisor Profile	Upper Left Incisor Profile	Define the profile of the upper left incisor using 3 points: 1. Root of upper incisor (UIroot_L) 2. Crown of upper incisor (UIcrown_L) 3. Labial point of upper incisor (Ullabial_L)
Upper Left Molar Profile	Upper Left Molar Profile	Define the profile of the upper right molar using 3 points: 1. Anterior root of upper molar (UMroot_L) 2. Anterior cusp of upper molar (UMcusp_L) 3. Posterior cusp of upper molar
Upper Right Incisor Profile	Upper Right Incisor Profile	Define the profile of the upper right incisor using 3 points: 1. Root of upper incisor (UIroot_R) 2. Crown of upper incisor (UIcrown_R) 3. Labial point of upper incisor (Ullabial_R)
Upper Right Molar Profile	Upper Right Molar Profile	Define the profile of the upper right molar using 3 points: 1. Anterior root of upper molar (UMroot_R) 2. Anterior cusp of upper molar (UMcusp_R) 3. Posterior cusp of upper molar
Upper Soft Tissue Profile	Upper Soft Tissue Profile	Trace the profile of the upper soft tissue with a series of points (double-click or right-click to finish tracing). The upper soft tissue is defined as including the upper lip.

## 3DAnalysis: Save Information

Whenever you save your file within Invivo, the .inv file will save any tracing tasks and measurements made within 3DAnalysis. The next time you open this .inv file, your measurements, references, etc. will all be saved from your previous session.



In addition, 3DAnalysis allows you to save your measurements to an external file. Press the Save Information button to bring up the following options:

- Build Norm Data
- Export Measurements
- Export Landmarks
- Export Tracing
- Save Current Configuration As
- Load A Configuration
- Reset to Default Configuration

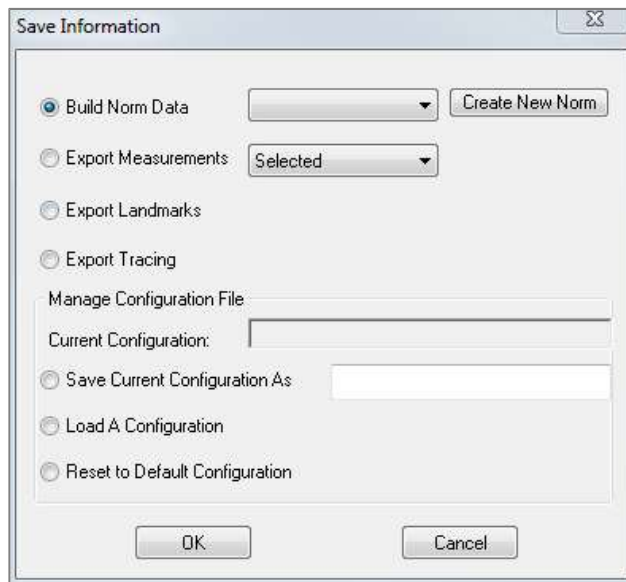

### Build Norm Data

In the drop-down menu, choose to which norm data file you want your new measurements to be added and press OK.

*Ex. Select “My Caucasian” to add your measurements to the “Caucasian” norm data files (without overwriting the “Caucasian” norm data). The Analysis tab of the Text View will now contain the data from the “Caucasian” norm data and the measurement data from your specific patient. The means and standard deviations will be updated accordingly.*

Press Create New Norm to create a new norm data file. The Define Group window will open; fill in an appropriate name and description of your new norm data file and press the User Define button to open up the User Define Norm Data window. Browse to where the new norm data file is stored and press Open. Press OK on the Define Group window to finish and close the window. Press OK in the Save Information window to import the new norm data set.

## Export Measurements

Select the “Export Measurements” option and press OK to export the current measurements of the patient. You will be prompted with the Export Measurements window where you can choose where you want your file to be written and the name of the file. Press Save when you have chosen your location and file name and all the current measurements will be saved as a .csv file for your reference. If you select an already existing .csv measurement file, your data will be appended to the end of the document. Using your preferred spreadsheet viewing program, you can open this .csv file to show all measurements in a spreadsheet format for further analysis. The delimiters for columns are semicolons (;).

## Export Landmarks

Exports the landmark names and coordinate data to a .csv file that can be opened by a spreadsheet program. The delimiters for columns are semicolons (;).

## Export Tracing

Select “Save Tracing” and press OK to export the position of the current landmark positions and profile drawings in a customized XML format. The Save Tracing Data window will open, and you can choose the location and name of the XML file.

## Save Current Configuration As

Saves the current configuration to a user-selected location. The configuration file name can be entered into either the blank box before clicking OK or chosen during the actual save to location process. The Current Configuration field will indicate which configuration file is currently being used.

## Load a Configuration

Opens a file browser to select a configuration file to be loaded. The program will provide a warning explaining that the current configuration will be overwritten. It is recommended that the user save the current configuration as a backup before continuing with the load. The Current Configuration field will indicate which configuration file is currently being used.

## Reset to Default Configuration

Resets the 3DAnalysis configuration to the installation settings.



### 3DAnalysis: 3D Surgery Tool

3DAnalysis allows the user to simulate surgical cuts and adjustments to better assess the surgical procedures necessary to achieve facial harmony.

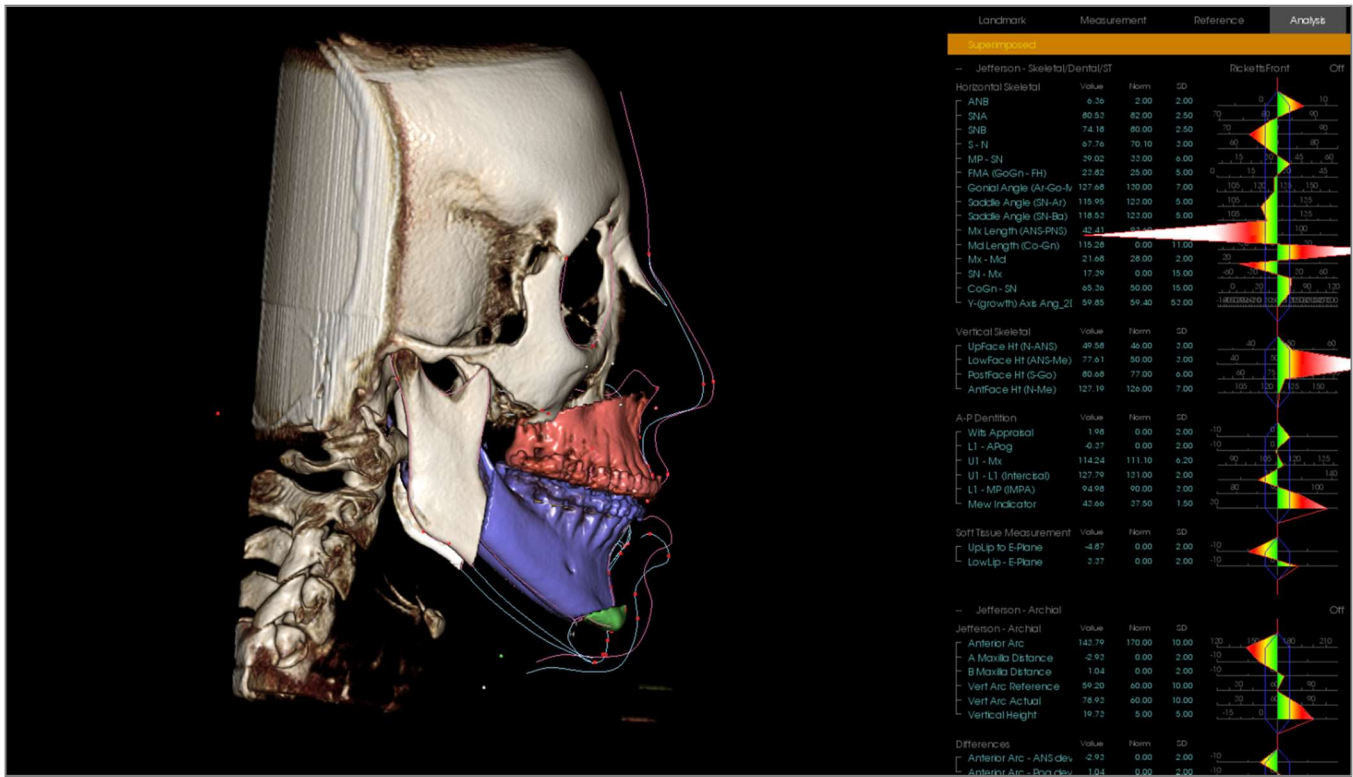

Warning: 3D Surgery tool's intended use is for patient consultation and statistical analysis only. For diagnoses, use Invivo.

Certain tracing tasks must be completed before performing certain surgical cuts or visualizing soft tissue deformation.

Maxilla Cut	Mandible Cut	Soft Tissue Deformation
ANS	Menton	Upper Soft Tissue Profile
PNS	Left Gonion	Lower Soft Tissue Profile
Upper Right Incisal Crown	Right Gonion	
Upper Right Molar Cusp	Upper Right Incisal Crown	
	Upper Right Molar Cusp	
	Lower Right Incisal Crown	

Subsequent adjustment of the tracing after using the 3D Surgery tool will undo the surgical simulations performed.

To begin, click on the 3D Surgery tool  to open the 3D Surgery window.

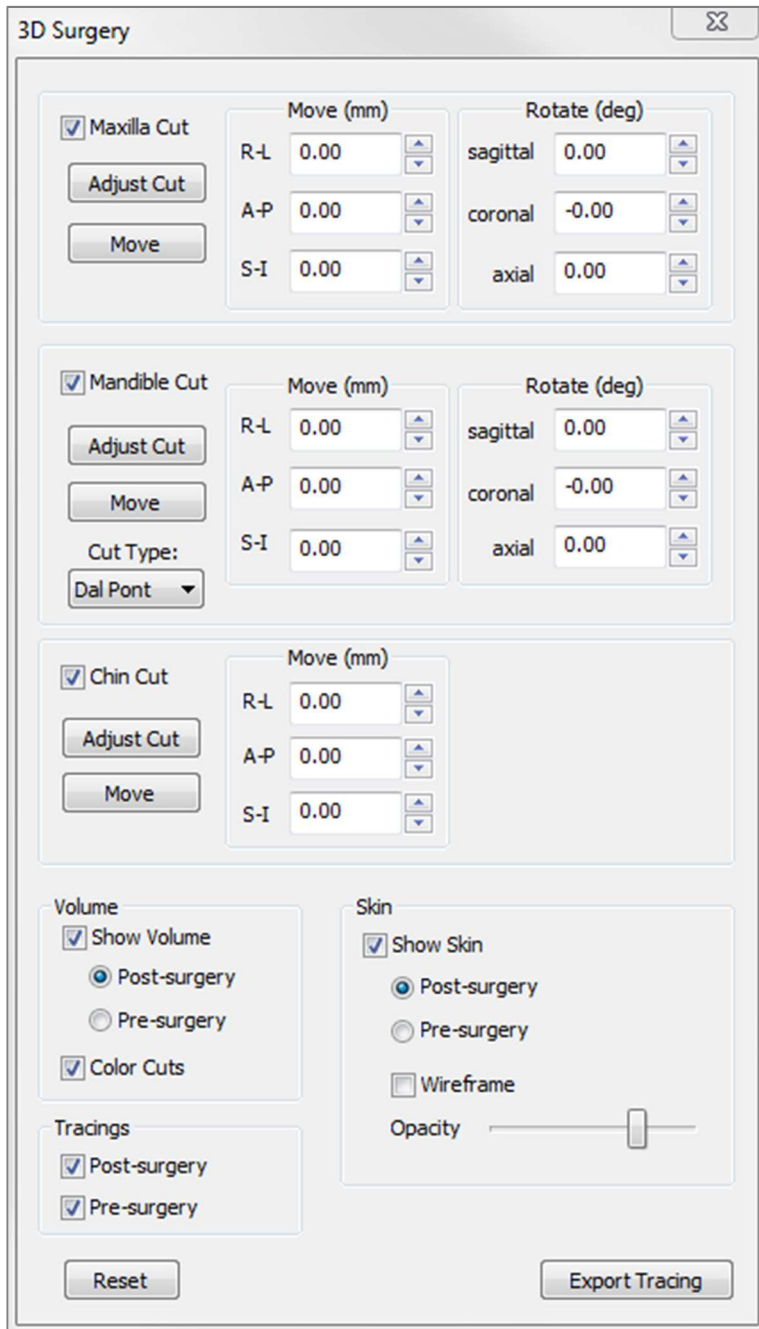

Maxilla, Mandible, Chin Cut: Automatically calculates a surgical bone cut when checked.

Adjust Cut: Adjust the size and angle of the cut by manipulating the volume of the cut. Adjusting the cut after the segment has been moved or rotated will reset its position.

Move: Moves the bone separated by the cut either through the widget tools that appear when the button is toggled on or by inputting values in the Move and Rotate fields.

Cut Type: Choose from Dal Pont, T&O, and Hunsuck cuts for the mandible.

Volume:

- Show Volume: Toggle the volume on or off and switch between the pre- and post-surgery states.
- Color Cuts: Colors the cut volumes distinctly from the rest of the volume.

Tracings: Toggle the visibility of the pre- and post-surgery tracings.

Skin: Toggle the visibility and adjust the opacity of the pre- or post-surgery skin if applicable. The “Wireframe” option will convert the skin to a wire mesh form when selected.

Reset: Resets all move and rotate values to zero.

Export Tracing: Exports post-surgery tracing. An exported tracing can be reimported as a superimposed tracing.

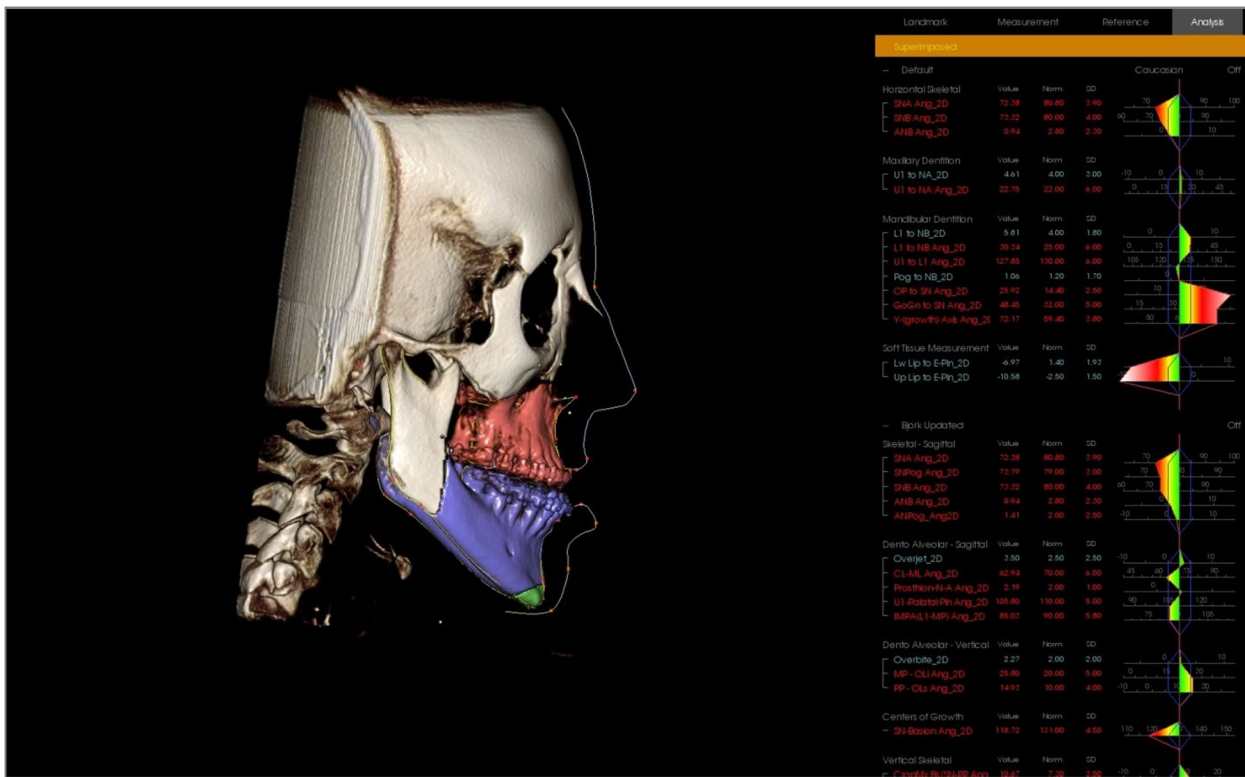

By moving the widget tools or entering values directly into the window, the bone sections can be manipulated. A post-op tracing is created, reflecting the changes. Once the post-op tracing is finalized, close the 3D Surgery dialog. If Text View is selected, the data of the pre- and post-op scans can be toggled by pressing the “s” key on the keyboard or click on the “Superimposed” or “Default Tracing” header below the Text View Tabs. To export the tracing, use Export Tracing in the 3D Surgery dialog.

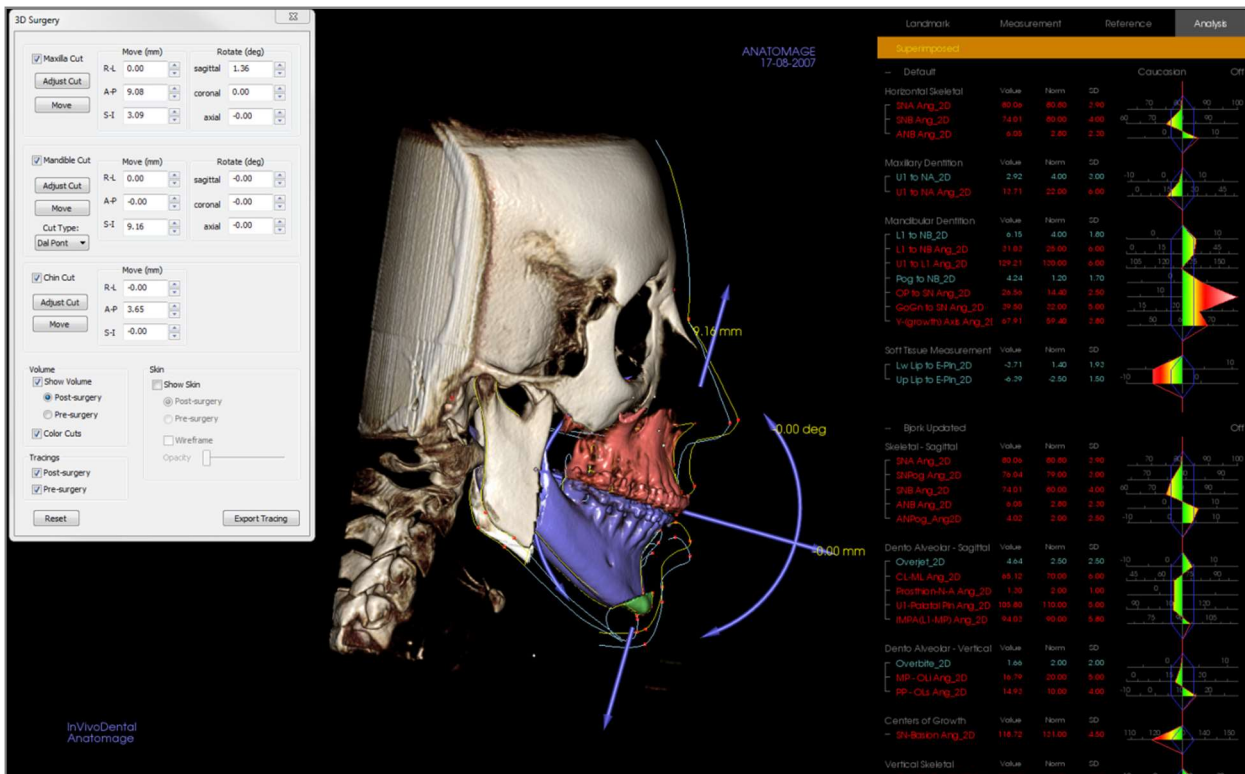

### 3DAnalysis: Profilogram

The profilogram is a simplified representation of the profile tracing based on a few landmarks. The required landmarks are:

- |                           |                           |
|---------------------------|---------------------------|
| Sella                     | Nasion                    |
| Right Orbitale            | ANS                       |
| A-point                   | B-point                   |
| Upper Right Incisal Crown | Lower Right Incisal Crown |
| Pogonion                  | Menton                    |
| Right Gonion              | Right Articulare          |
| Right Porion              | Left Porion               |

Once the above tasks are traced, click the Profilogram  icon. The graphic will automatically be generated. If 3D Surgery was performed on the patient or if a tracing was superimposed, the original tracing's profilogram will be drawn with a solid line, while the superimposed tracing will be drawn with a dashed line.

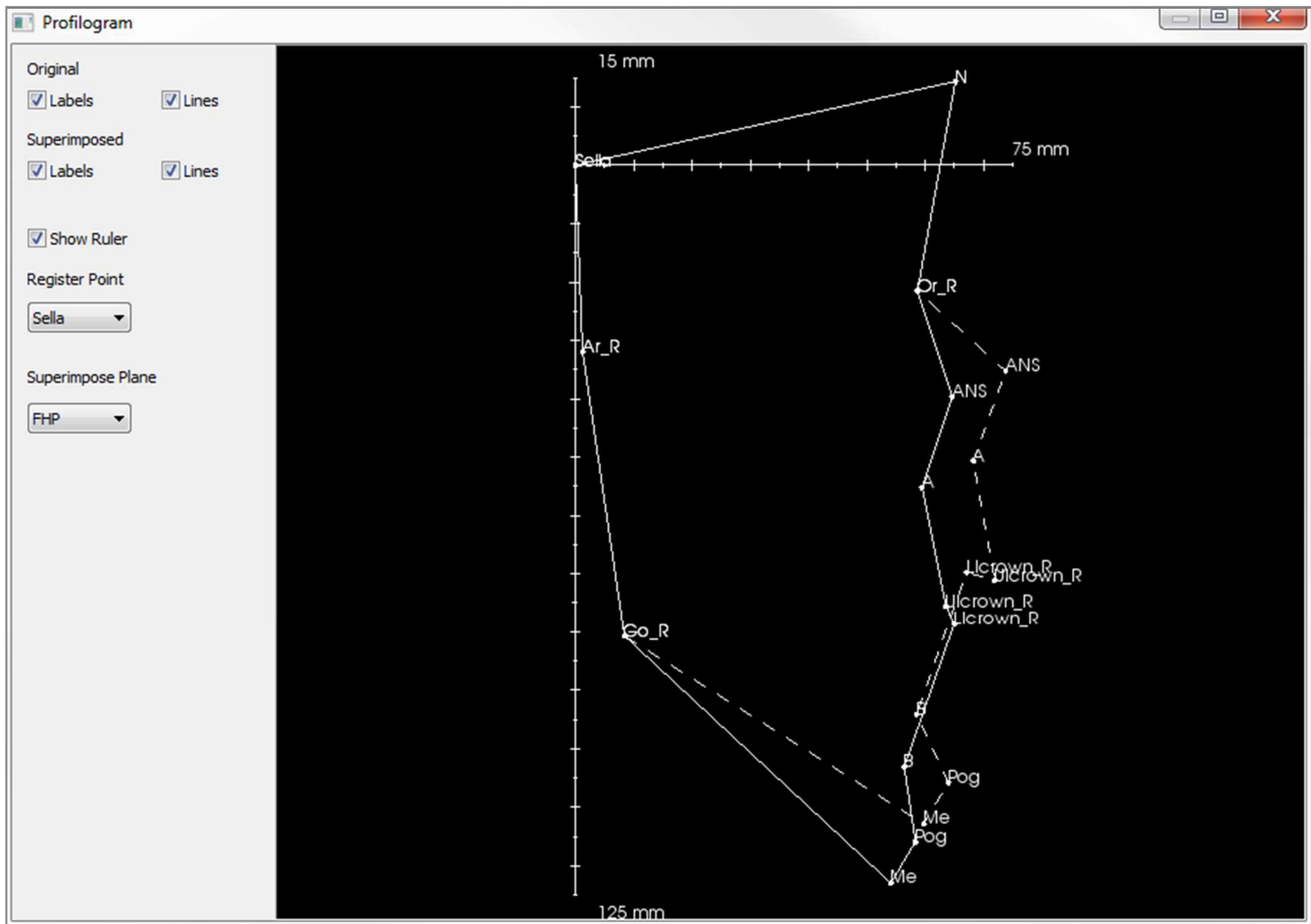

Additional visibility options on the left will allow the user to hide or display labels, lines, and the ruler.

By default, the profilogram will be registered on the sella and superimposed about the Frankfort horizontal plane, but this is customizable in the Profilogram dialog.

# Report Module Features



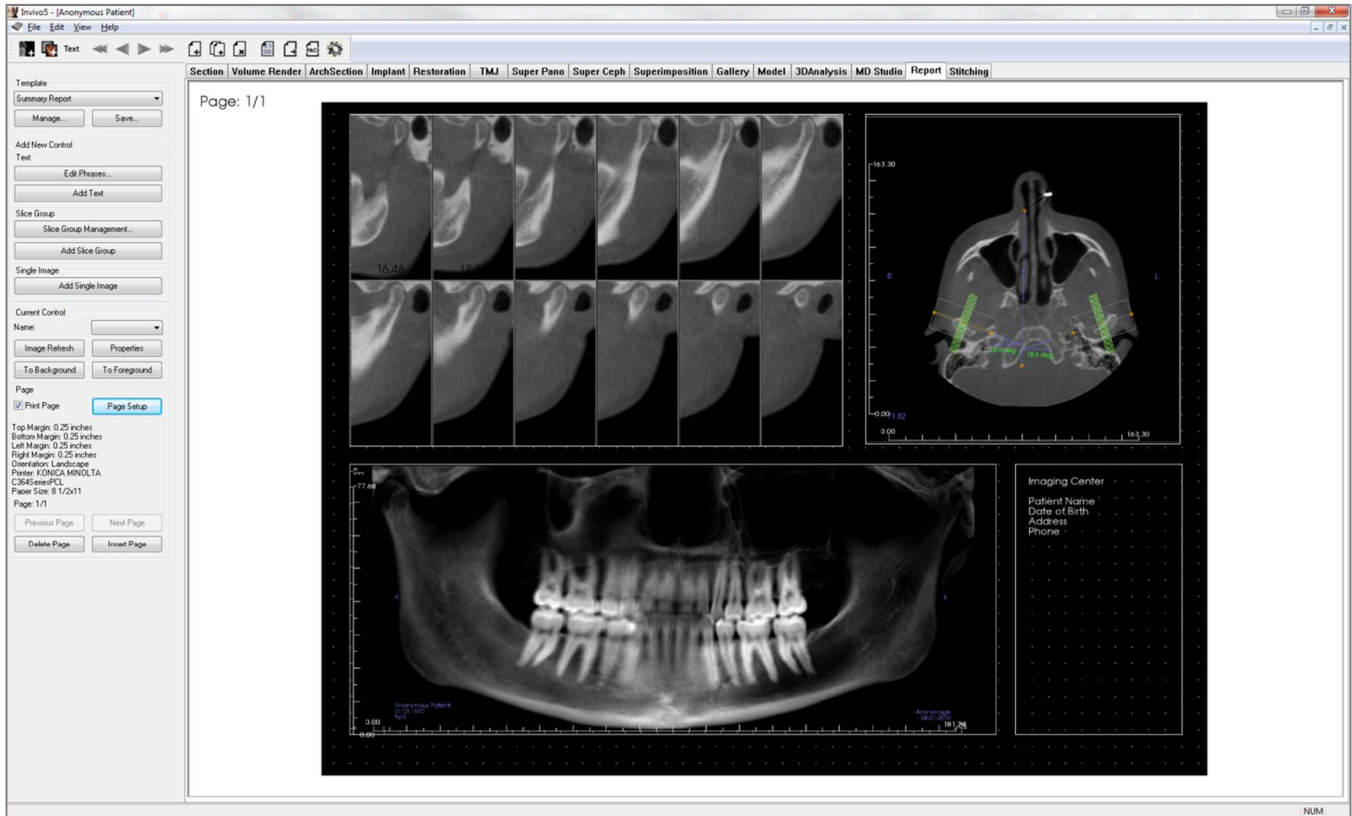









The Report View Tab allows for the creation of templates containing images and text. A template can be applied to any case using this tab. In this picture, the page background is black and represents the page. Several types of items can be placed within this page to create a detailed report for the patient.



## Report: Toolbar

Shown below are the Toolbar and tools that are loaded with the Report View Tab:



	Add Image: Adds a control to add a single image.
	Add Slices: Adds a control to add single slices or a group of slices.
<b>Text</b>	Add Text: Adds a control to add text.
	First Page: Navigates to the first page of the report.
	Previous Page: Navigates one page back.
	Next Page: Navigates one page forward.
	Last Page: Navigates to the last page of the report.
	Insert Page: Inserts a page after the current page.
	New Page: Adds a page to the end of the report.
	Remove Page: Deletes the current page.
	New Template: Creates a blank template.
	Export PDF: Saves the report as a PDF file.
	Export to PACS: Saves the report as a DICOM onto the PACS server. Requires PACS configuration beforehand.
	Preferences: Opens preferences for default colors, default image type, default page setup, grid alignment, and the template save path.

## Report: Control Panel

### Template

- Template drop-down: Lists the available templates.
- Manage...: Displays all of the preset templates. Templates can also be loaded, renamed, and removed in this dialog. See pg. 205.
- Save...: Saves the current template. Templates are stored locally and show up on the drop-down.

### Add New Control

#### Text:

- Edit Phrases...: Opens a dialog for managing common phrases to be added to text controls. See pg. 195.
- Add Text: Adds a control for text.

#### Slice Group:

- Slice Group Management: Allows creation and management of image groups.
- Add Slice Group: Adds a control for 2D slices.

#### Single Image:

- Add Single Image: Adds a control for one image.

### Current Control

- Name drop-down: Shows the name of the currently selected control from a list of controls on this page. Each control can be selected from the drop-down menu instead of clicking the control.
- Image Refresh: Updates the image according to the changes in the source image.
- Properties: Opens the Properties window for the current control.
- To Background: Puts the selected image behind other images.
- To Foreground: Puts the selected image in front of other images.

### Page Control

- Print Page: Enables the current page to be printed.

- Page Setup: Opens page setup to allow you to set printer, paper size, margins, and background/border properties of the page.
- Page Information is displayed showing the current settings.
- Previous/Next Page: Page navigation controls.
- Delete Page: Removes the current page.
- Insert Page: Inserts a page after the current page.

## Report: Rendering Window

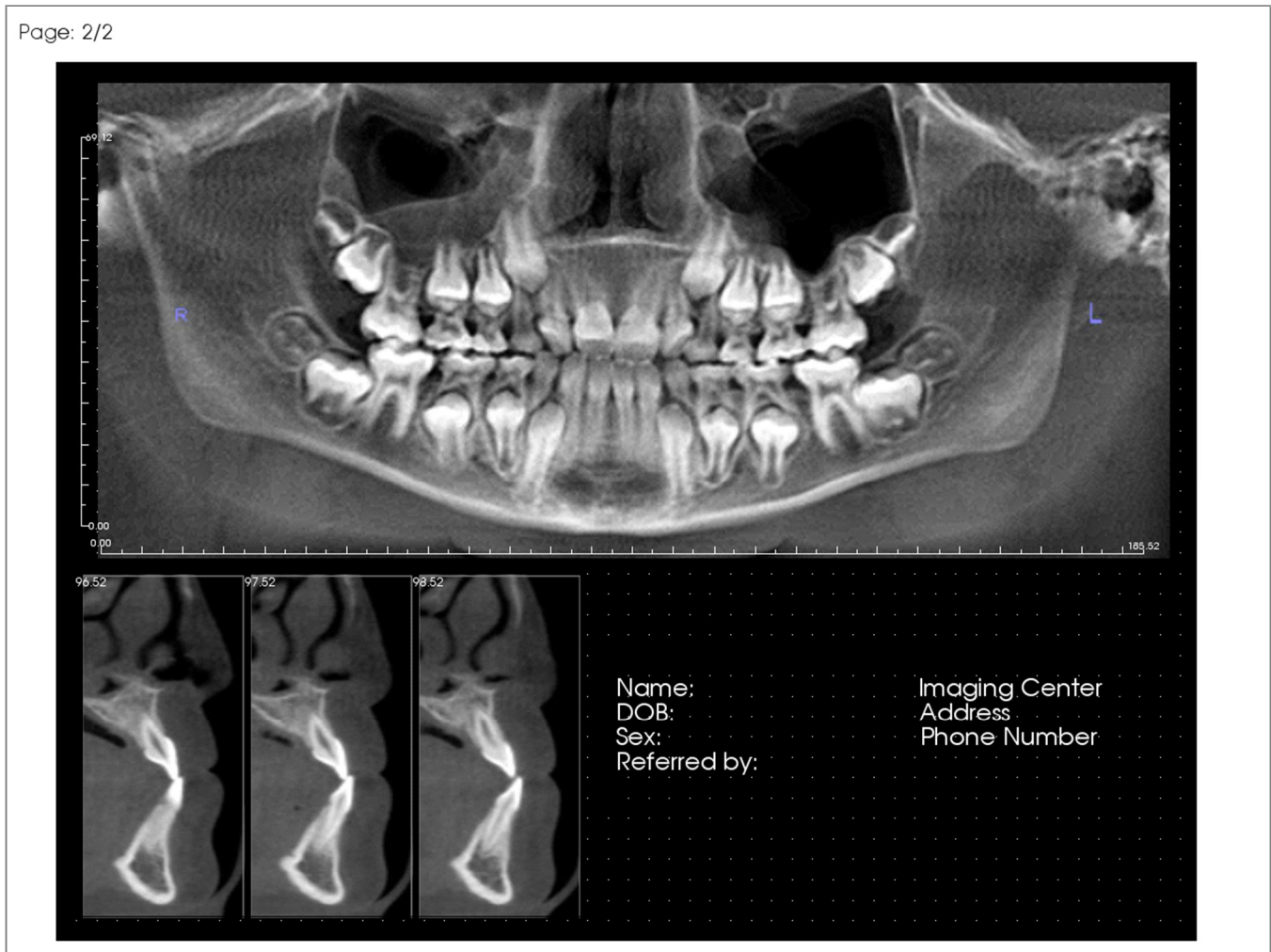

The rendering window displays the report page and is the main area for designing and viewing reports and templates. The page navigation buttons in the toolbar allow the user to switch between pages in a multi-page report to choose which is displayed in the rendering window.

Adjusting the position and zoom of the report within the rendering window uses the same keyboard and mouse combinations as in other Invivo tabs:

Zoom – Ctrl + Left-Click + Drag Mouse

Pan – Shift + Left-Click + Drag Mouse

For additional keyboard and mouse shortcuts relating to the Report Tab, see the Full Screen and Keyboard Shortcuts section (pg. 35).



## Report: Controls

Controls are boxes that display text or image data.

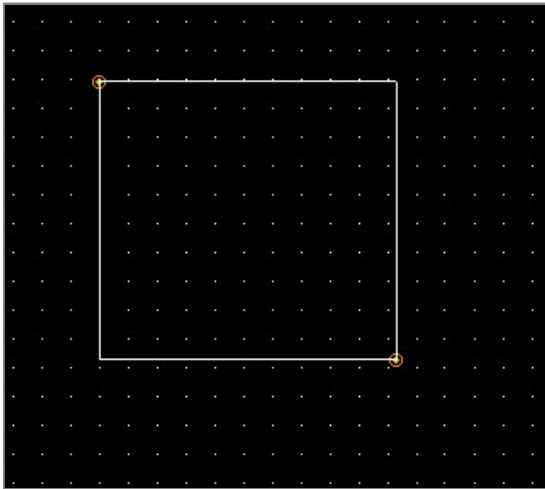

### Adding and Sizing

- Navigate the mouse cursor to the Control Panel on the left and select the button labeled Add Text, Add Slice Group, or Add Single Image.
- Size the control: The image on the left shows the control rectangle during creation. The control is created by two separate points and will not show up until after the first point has been placed.



**Warning:** If you create the control outside of the page, you will receive an error message and the control will not be created.

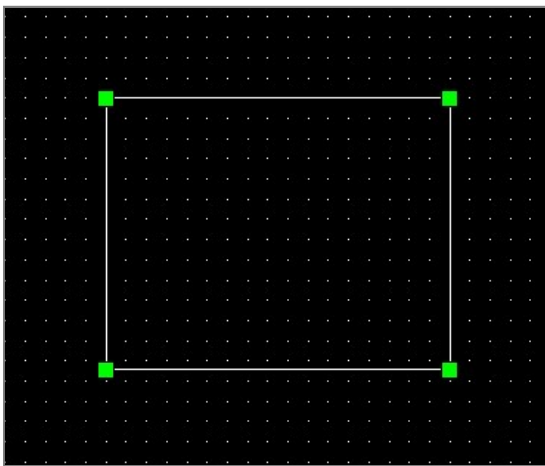

### Resizing and Customization

- After creating the control, it will look like the image on the left.
- Resize the control: Click and drag the green squares or the borders. Alternatively, set the height and width from the Properties window.
- Move the control: Click and drag with the left mouse button or use the arrow keys on your keyboard after clicking inside the control.
- Select a control: Click on the control or select it from the Name drop-down on the Control Panel. Pressing the Delete key will delete the control. To see the control's properties, press the Properties button while it is selected. Double-clicking the control also shows its properties.
- Select multiple controls: Click more than one control while holding the "Ctrl" key on the keyboard. Supported multi-control operations are movement and deletion.
- Copy and paste controls: Select a control, press Ctrl + C, then press Ctrl + V to paste it at another location.

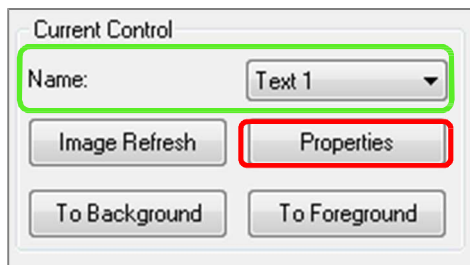

## Report: Adding Text Controls

Text Controls contain text that is manually typed in or drawn from the Case Info.

Adding a Text Control:

- Click the Add Text button.
- Properties can be changed by clicking Properties in the Current Control section of the Control Panel.

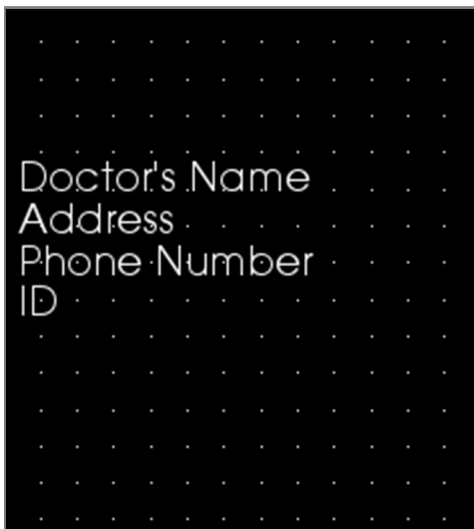
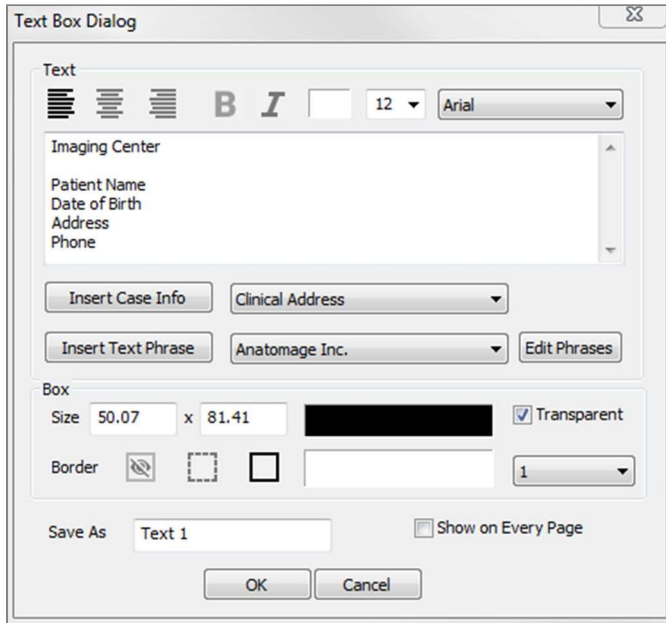

### Text Box Dialog

This dialog can be opened by double-clicking on a text control or selecting the control and clicking Properties on the Control Panel.

### Text

- Alignment type: Select the text alignment type.
- Font Options: Family, size, color, alignment, bold, and italics can be changed.
- Text Input Box: Enter text to be displayed in this text box.
- Insert Case Info: Inserts the selected data based on the case information or Gallery comments where the cursor is in the Text Input Box.
- Insert Text Phrase: Inserts the selected text phrase where the cursor is in the Text Input Box.
- Edit Phrases: Opens the Text Phrases dialog (See pg. 195).

### Box

- Size and color: Determines the size of the text control. Unchecking “Transparent” will show the chosen color instead of the report’s background color.
- Border: Set the border style, color, and thickness. Style can be dashed, solid, or none (not displayed).

### Save As

- Choose the name of the control.

### Show on Every Page

- Check this option to show the text in the control on every page of the template.

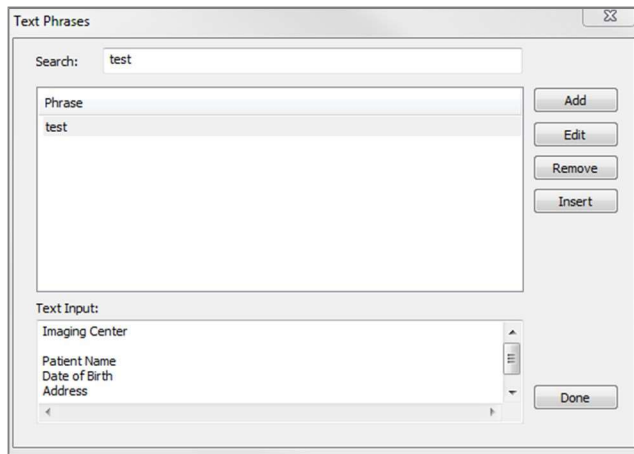

## Text Phrases

Text phrases allow you to store common phrases within the software and insert them into text controls. This dialog can be opened by click on Edit Phrases.

- Search: Searches for the term in the list of stored phrases.
- Add: Opens a dialog for creating a new phrase.
- Edit: Opens a dialog for editing the selected phrase.
- Remove: Removes the selected phrase.
- Insert: Inserts the selected phrase into the text control.
- Text Input: If a text control is selected, type directly into the box to update the text control on the report.

## Report: Slice Group Management

Groups are created in the Report Tab and used in slice controls. The groups are populated from ArchSection and TMJ Tabs only.

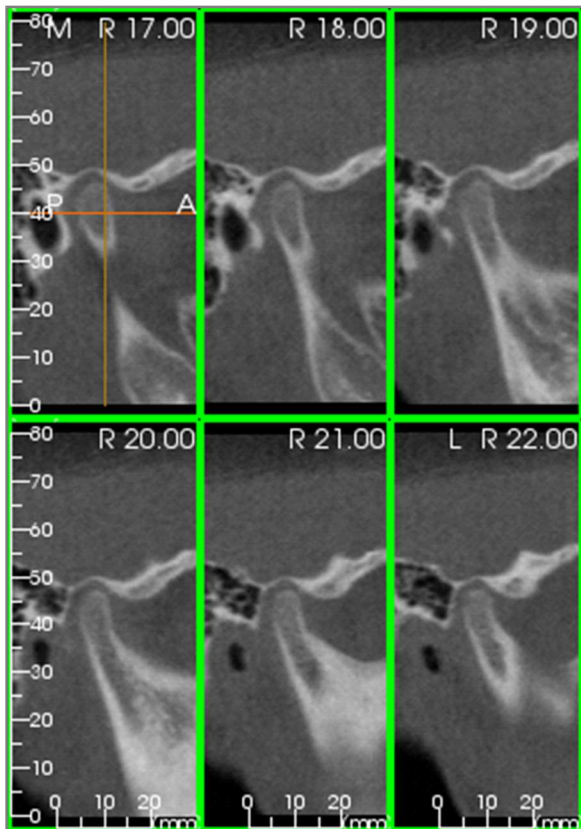
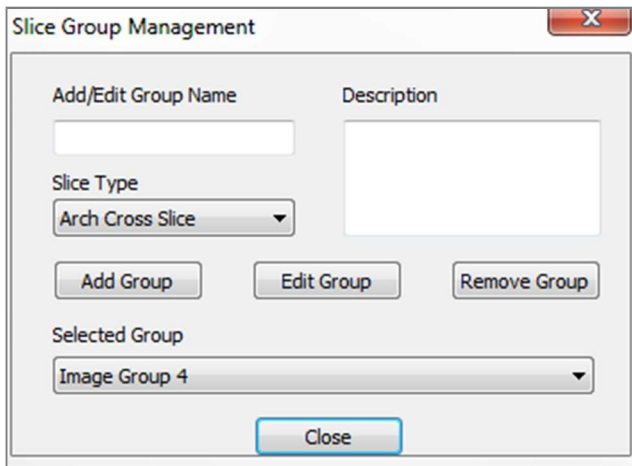

**Slice Group Management:** To add/modify groups, click the Slice Group Management button in the Page section of the Control Panel.

**Add/Edit Group Name:** Name of the new group or the new name of the selected group.

**Slice Type:** Type of slice for this group.

- Arch Axial Slice: ArchSection Tab's axial slice mode
- Arch Cross Slice: ArchSection Tab's cross-section slice mode
- TMJ Left Cross Slice: TMJ Tab's left cross slices
- TMJ Right Cross Slice: TMJ Tab's right cross slices

**Description:** Optional description for group.

**Add Group:** Adds the new group to the template's groups.

**Edit Group:** This will replace the selected group with the new group. If the slice type changes, all of the slices will be removed. If any slices in this group are not in other groups, they will also be removed from the case file.

**Remove Group:** This will permanently delete the currently selected group from the current template. If any slices in this group are not in other groups, they will also be removed from the case file.

**Selected Group:** This holds all of the existing groups on the template. Can be selected for Edit and Remove operations.

*The image on the left displays the corresponding slices for this particular Slice Group.*

## Adding Slices to a Group

**Note:** Only the ArchSection and TMJ Tabs allow you to capture slices to a slice group.

ArchSection and TMJ Tabs have a toolbar button (shown below) that will enable the slice-capturing mode. While in this mode, you can see all captured slices for a selected group. It also allows you to add or remove slices from the slice group.



Slice Capture Mode – This will open the dialog that will enable you to capture slices to a group.

## Capture Slices Dialog:

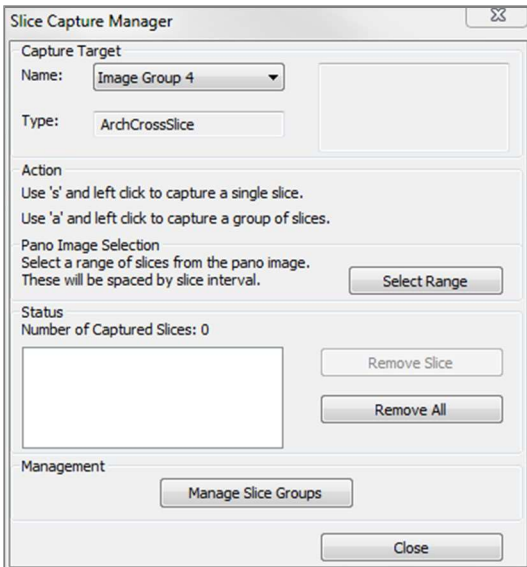

**Capture Target:** Allows selection of group to add/remove slices. All parameters are read-only here. The selection of slices can be modified in the Slice Group Properties in the Report Tab.

- Name: Name of the current group
  - Type: The group's slice type
  - Description: Optional description for this group
- Action:** Description of the capture slice options (discussed in more detail in the next section).

**Select Range:** Allows use of the pano or frontal image to capture the slices. Press the Select Range button then pick two points on the pano to mark the start and end slices. All of the slices in between will be added to the group. The number of slices depends on the slice interval and slice thickness set.

**Status:** Allows viewing of all slices in this group.

- Number of Captured Slices: List of all slices in the current group with a count of the total number
- Remove Slice: Remove the selected slice(s)
- Remove All: Removes all captured slices

*The image on the left displays the corresponding slice that would be captured with this Slice Group.*

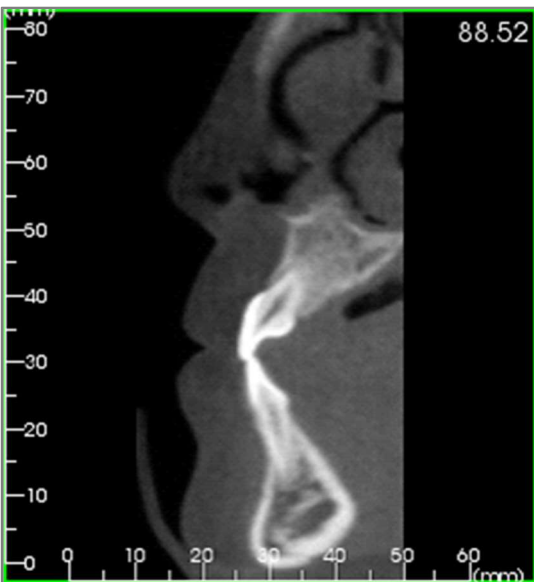

## Management

- Manage Slice Groups: Opens the Slice Group Management dialog.

## Capturing Slices

There are three ways to capture a slice in the capturing mode in the ArchSection or TMJ Tabs. All captured slices for the current group will have their frames highlighted in green in the source tabs. Their locations will also be marked on the pano and frontal images. Arch axial slices will not be marked on the pano. **Note: For the arch axial slice type, ArchSection layout must be in lightbox mode with axial sections chosen for capturing. Slices outside the selected group's slice type cannot be captured.**

## Slice Capture

- Single Slice Capture: Hold the “s” key on the keyboard and left-click any slice to capture it. The selected slice will be highlighted. **Note: Repeating this will deselect the slice.**
- Group Slice Capture: Hold the “a” key on the keyboard and left-click any slice to capture it. Click on another slice, and all slices in between the two slices will be captured including the second slice.
- Select Range: This will capture slices within a range designated in the pano or frontal images depending on the view. **Note: This is not available for arch axial slices.**

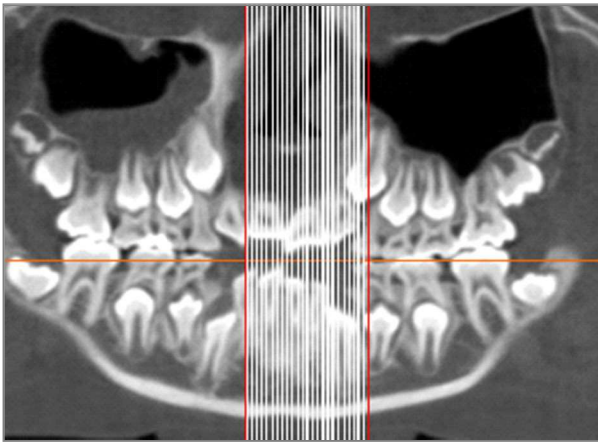

The image above shows the configured slice range on the ArchSection pano.

**Note: If slices have already been captured to the Report Tab, white lines denoting these slices will be seen on the pano even before the Select Range function is used. Use the Toggle Visibility tool to hide these lines.**

Select two points on the pano in ArchSection or the frontal images in TMJ.

- After clicking once on the image, a red line will appear. This is the starting slice of what will be captured.
- When clicked a second time, all slices between the red line and the second point will be captured. A second red line marks the end slice. White lines will denote every captured slice as defined by the cross-section parameters. See image to the left.
- A gallery image with the slice group name of the pano or frontal will be added. If it already exists, it will be replaced. **Note: This will replace any other image with the same name regardless of how it was captured to Gallery.**

## Report: Adding Slice Group Controls

Slice Group Controls can hold a single slice or a series of slices. (See Report: Slice Group Management, pg. 205.)

**Note:** If no slice groups exist, you will be prompted to create one.

Adding a Slice Group:

- Click the Add Slice Group button.
- Properties can be changed by clicking Properties in the Current Control section of the Control Panel.



**Warning:** When resizing a Slice Group Control, note that the slice numbers will disappear if the control is downsized past a limit (approximately the size that the numbers can no longer fit within each respective slice).

### Slice Group Box Properties

### Source

- Sync to Source: Select to update the image automatically if it is changed. If disabled, images can be refreshed with the Image Refresh button.
- Slice Groups or Selections: Determines if slices are added by group or individually by slice. See the next page for more information on Slice Image Source.

### Layout

- Columns/Rows: Determines the arrangement of slices within the control.
- Note: If there are not enough rows and columns for the amount of chosen slices, some slices will not be displayed.

### Display Mode

- “Fit” will stretch the image to fit the control while maintaining aspect ratio. “Clip” will use clipping to fill the control space.
- Image Alignment: Determines how the image will be oriented within the control.
- See Image Alignment on pg. 203 for more details.

### Box

- Size and color: Determines the size of the text control. Unchecking “Transparent” will show the chosen color instead of the report’s background color.
- Border: Set the border style, color, and thickness. Style can be dashed, solid, or none (not displayed).
- Ruler: Set on which borders rulers will be displayed and the color.

### Save As

- Choose the name of the control.

### Show on Every Page

- Check this option to show the content on every page of the template.

**Slice Image Source Details:**

Images can be added to Slice Group Controls by group or by manual selection:

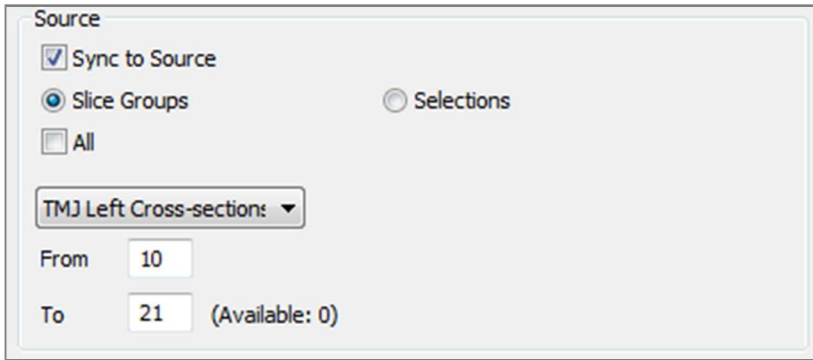

**Slice Groups:** Displays slices from a single group. Refer to Report: Capturing Slices (pg. 205) for more information on the restrictions and functionality of slice range.

- Selected Group: The slice group to use as the source.
- Start Slice: First slice to be displayed from the group.
- End Slice: Last slice to be displayed.
- If “All” is checked, all of the slices from the selected group will be displayed.

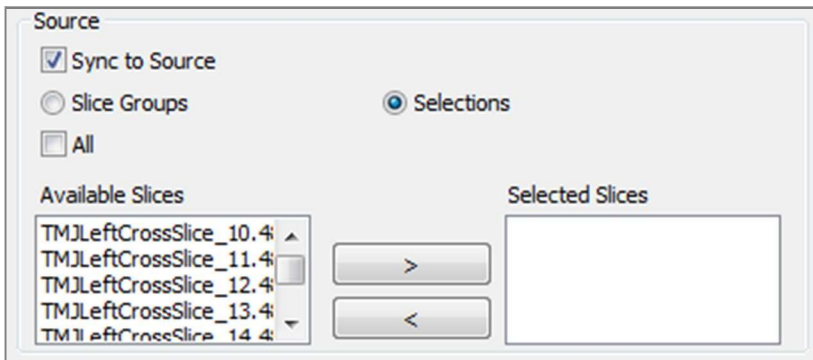

**Selections:** Manually add captured slices one by one to be displayed.

- Available Slices: All slices captured in the current case file.
- Selected Slices: All slices chosen to be displayed in this control.
- > Button: Moves selected Available Slice(s) to Current Slices for display.
- < Button: Moves selected Current Slice(s) to Available Slices to no longer display.
- If “All” is checked, all of the captured slices will be displayed.



### Slice Control Selection Details

Start and end slice are determined by their slice numbers. This number can be seen on each slice in the upper right. This is only enabled for single groups. When selecting the range of slices to be displayed, the number indicates which slice in the series is shown and does not correspond to the slice number itself.

- Start Slice: What slice in group to start displaying. 0 defaults to the first slice.
- End Slice: What slice in group to stop displaying. 0 defaults to last slice.

### Slice Range Examples:

- You can show the first two slices by setting Start Slice to 1 and End Slice to 2. You could also show the next two by setting the start to 3 and the end to 4.
- All slices can be shown by setting Start and End Slice to 0.
- If Start Slice > End Slice, only the End Slice will be shown.
- If Start Slice > Number of slices and End Slice = 0 or End Slice  $\geq$  Number of slices, then only the last slice will be shown.
- If either is set to blank, they will default to 0.
- If End Slice > Number of slices, the last slice will be the End Slice.

## Report: Adding Single Image Controls

Control that holds a single image from a selected source view.

Adding a Single Image Control:

- Click the Add Single Image button.
- Properties can be changed by clicking Properties in the Current Control section of the Control Panel.

### Single Image Box Properties

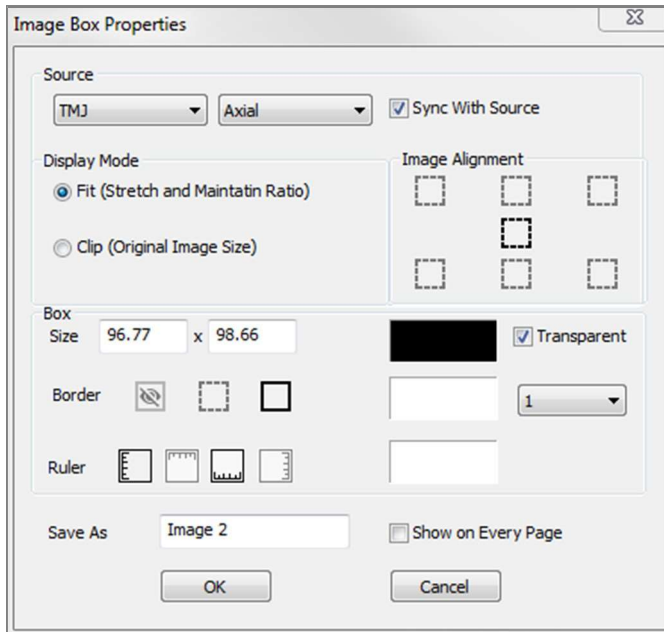

### Source

- Determines the exact image to be displayed from the source view (Note: Images will not be available until the specified source view has been “visited” to provide an image to load. See Report: Image Type Definitions, pg. 204, for details on dynamic images.)

Sync with Source, Display Mode, Image Alignment, Box dimensions and properties, Save As, and “Show on Every Page” control the same properties as for Slice Groups (see Report: Adding Slice Group Controls, pg. 199).



**Warning: Bitmaps under 24 bit may not display correctly.**

## Report: Image Alignment

For Slice Group Controls and Image Controls, images may be aligned to the control boundaries by two methods.

- Fit: Resizes the image to fit within the borders of the control as determined by the Image Alignment settings.

This example is done with a bottom left fit alignment position with a white background.



The image will originate from the bottom left and will show the background above it or to the right when it does not fill the control.

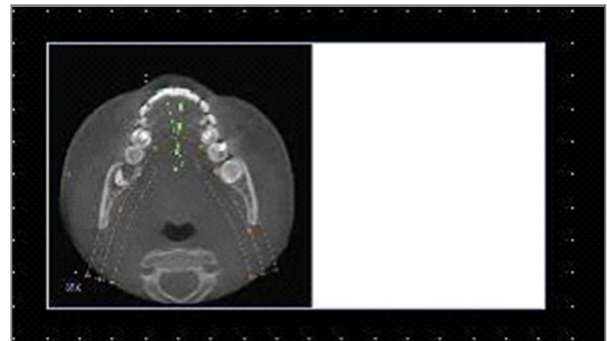
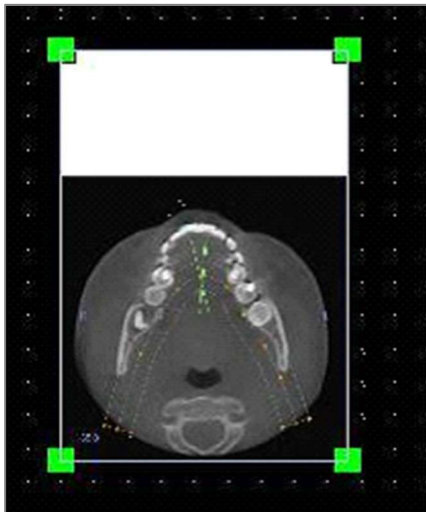

- Clip: The original image size is maintained. The control may need to be resized in order to display the full image.

## Report: Image Type Definitions

### Dynamic Images:

These images can always be up-to-date with the latest changes performed on them if desired. When adding an image to a control, the user can choose not to auto-update the image, keeping the current image until the auto-update setting is changed or the image is manually refreshed. There are two types of dynamic images.

*Note: Capturing images from specific layouts requires that the layout is currently selected when leaving the aforementioned view tab and reloading the Report Tab. Ex. The pano screen in the Implant Tab will not be captured unless the Pano layout is on when leaving the view.*

- Single image view sources except Gallery and external images are dynamic.
  - To populate the image source with images, go to a view tab. As you leave the view, images for that view are captured.
  - After an image has been added to a control, it will update when changes are made in that view. For example, if a measurement is added to Section Tab's axial view, the image in the Report Tab will now display that measurement.
  - These images are saved with the case file.
- Slice images
  - These are captured manually.
  - These are the input for the Add Slice Control.
  - They have the same dynamic update behavior as above.
  - These images are saved with the case file.

### Static Images:

These images will never change unless you manually change the source image. There are two sources of static images.

- Gallery
  - All images in the Gallery are either captured from other tabs or imported by using the Import Images function. They will not always be life size.
  - These images are saved with the case file.
- From a File
  - These images come from the local computer or another source. They will never be life size.
  - These images are saved with the template.
  - If an image that already exists in the template is added, the software will prompt whether to replace the image or keep using the older one.

## Report: Managing Templates

Once a report layout is created, it can be saved and reloaded in other cases as a template. Templates are saved locally in the file path designated under “Template Path” in the Preferences dialog. These saved templates will automatically appear in the drop-down menu. To display a preview of all the available templates or to edit them, click on Manage... on the Control Panel.

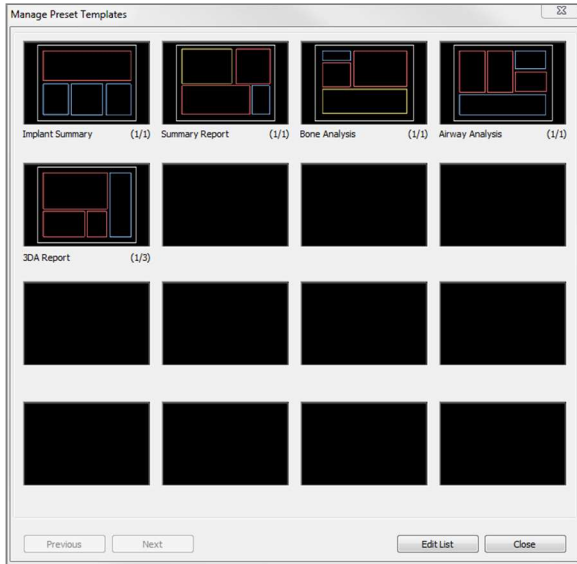

### Manage Preset Templates

- All of the saved templates will be shown here.
- Each color represents a different type of control:
  - Blue: Text control
  - Red: Image control
  - Yellow: Slice group control
- Templates may also be loaded from this window by left-clicking on them.
- Previous/Next: Goes to the previous or next page of templates, respectively.
- Edit List: Opens a dialog for editing template properties.
- Close: Closes the dialog.

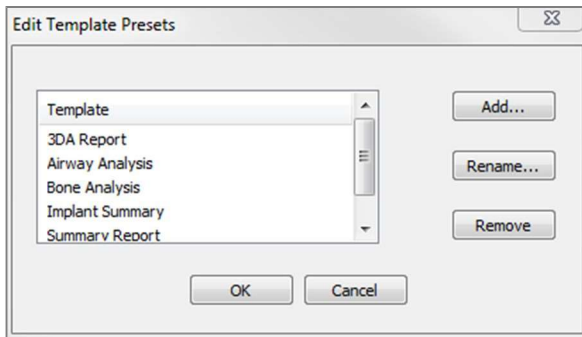

### Edit Template Presets

- Add...: Load an existing template that was saved elsewhere.
- Rename...: Rename the selected template.
- Remove: Remove the selected template.

## Report: Preferences

### Alignment Grid:

- Grid dot spacing: Defines the distance between grid dots.
- Grid dot color: Set the color of the grid dots.
- Hide Grid: Toggles the visibility of the grid.

Default Control Colors: Colors for border, background, font, and rulers.

Default Image Type: Choose between “Fit” or “Clip” display modes.

### Default Page Setup:

- Printer: Printer in current use. This changes the available paper sizes. This list includes all of the printers available to the computer.
- Paper Size: Uses the printer drivers to set the height and width of the page.
- Orientation: Portrait or landscape setup.
- Margins: Margins (in inches) for the template. Used for where controls can be placed.
- Background: Color and transparent options.
- Border: Color, thickness, and style options for the border. Styles are solid line, dotted line, or no line at all.
- Margins: Margins for the border. This can differ from the page margins.

Behavior: Specifies behavior of the template during design.

- Enable Alignment Grid: If checked, all controls will attach to their top left corner to the nearest grid point. If unchecked, they will be placed wherever the user drags them.
- Display Numbers on Print: If checked, the report page number will be displayed in the printout.

## Report: Page Setup

This displays and allows configuration of the page settings. These are the settings the template uses. When printing, the correct printer and paper size must be chosen from the print setup.

**Note:** The first time the software loads, your default printer configuration is used to set the printer and paper size for the report. Report defaults can be changed from the Preferences menu.

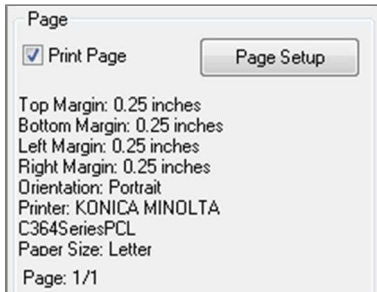

### Page Setup:

To modify page settings, click the Page Setup button in the Control Panel.

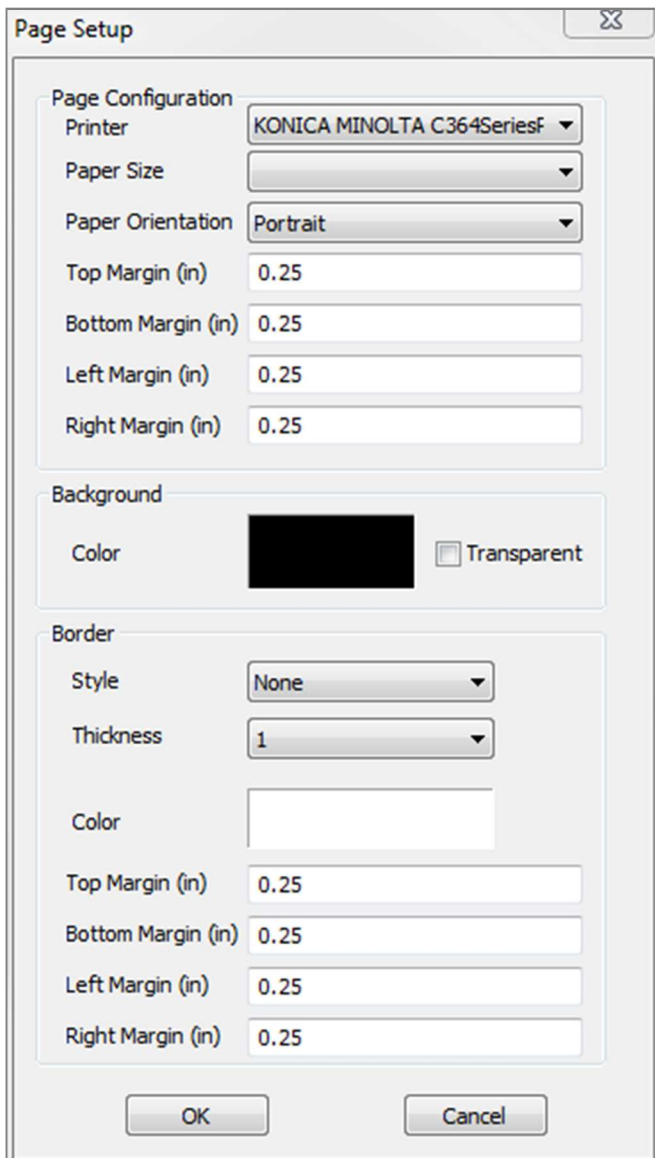

### Page Configuration:

- Printer: Printer to use for this template.
- Paper Size: Current paper size. Only displays paper sizes for the currently selected printer.
- Paper Orientation: Portrait or landscape orientation. (Note: Margins will not change, so paper may appear to have different proportions when switching between portrait and landscape.)
- Margins: Margins (in inches) for the page.

### Background:

- Checking transparent will show the chosen color instead of the background.

### Border:

- Set the border color, thickness, and style.
- Style can be dashed, solid, or none (not displayed).
- Margins: Location of the borders.

*Page information of the chosen configuration will always be displayed in the Page section of the Control Panel.*

# Stitching Module Features

*The Stitching View Tab provides the ability to merge two DICOM data sets. This will give you the ability to utilize CBCT machines with smaller fields of view fully.*

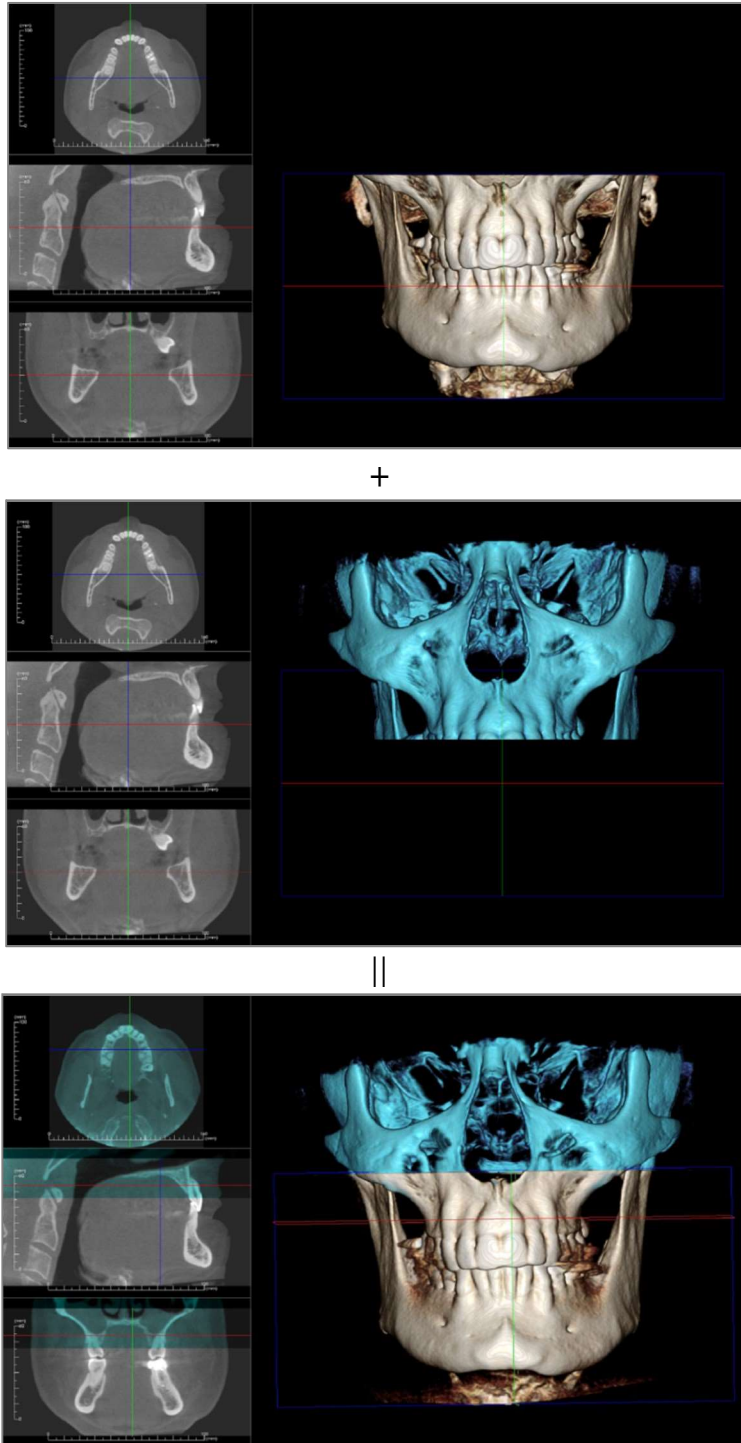



Warning: Stitching module is not a medical device and should be used as a reference or presentation tool only.

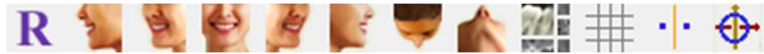

## Stitching: Toolbar

Shown below are the Toolbar and tools that are loaded with the Stitching View Tab:





 **Reset:** Resets the modeling window to the original view size.

 **View Angles:** Quick view angle presets.

 **Layout:** Toggles the rendering window layout.

 **Grid:** Toggles between different grid layouts on the volume, allowing quick assessment of measurements and spatial location.

 **Landmark Registration:** This tool is used to register the original volume to the imported volume. Four or more anatomical points are chosen from each scan to properly align them.

 **Move Widget:** This tool is used to make adjustments to align the two volumes better.

## Stitching: Control Panel

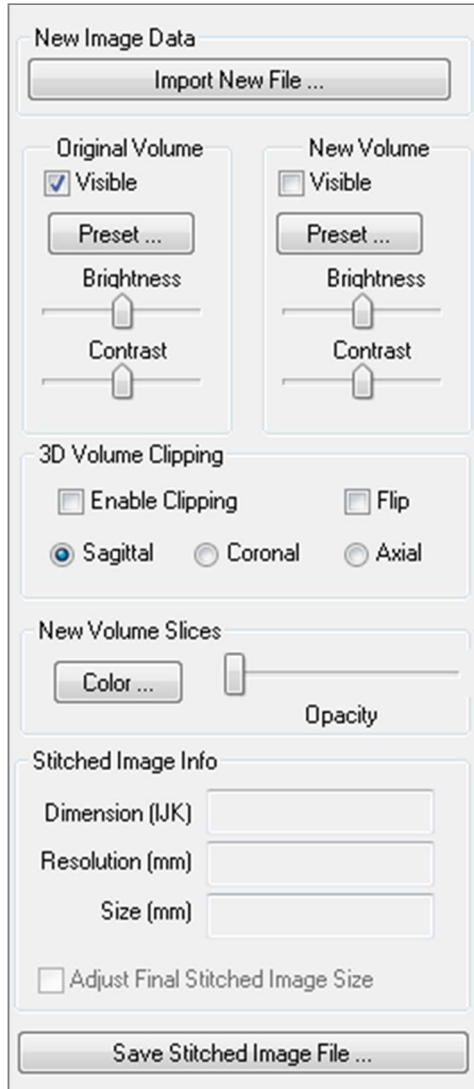

**Import New File:** Used to import the second volume by opening an invivo file (.inv) or DICOM (.dcm) of your choice.

**Original Volume and New Volume:** Different viewing options, such as visibility, rendering type, brightness, and contrast for each volume can be selected or adjusted independently.

**3D Volume Clipping:** Click the “Enable Clipping” box to clip the image along the predefined anatomical planes (sagittal, axial, coronal, and arch). Scrolling the mouse wheel or moving the slider will move the clipping plane. To switch a view to the opposite side, click “Flip.”

**New Volume Slices:** The Opacity slider adjusts the opacity of the superimposed volume. The Color button changes the color of the superimposed volume.

**Adjust Final Stitched Image Size:** This feature will allow you to set new boundaries for the stitched scans. If the stitched volume does not fit into the window or is off centered, you can use this feature to adjust the boundaries.

**Save Stitched Image File:** This button will save the stitched volumes into an invivo file. Upon saving, the two volumes will be merged and open as a regular Invivo file.

## Stitching: How to Stitch Two Volumes

Invivo provides an easy-to-use tool that combines two volumes to create a larger field-of-view scan. Although it is easy to use, it is a technique-sensitive feature with the most critical step being the registration of the scans by selecting stable landmarks. The next section shows how to stitch two scans step by step.

Step 1. Save DICOM Files as Invivo Files.

Both scans are recommended to be saved as Invivo files (.inv) before proceeding. See the section on Invivo File Saving if you are not sure how to save your DICOM files as Invivo files.

Step 2. Open the First Invivo File.

Open the first Invivo file. You do not have to open them in any order.

Step 3. Import Volume.

Go to the Stitching Tab. Click on the Import New File button on the Control Panel to select the second scan:

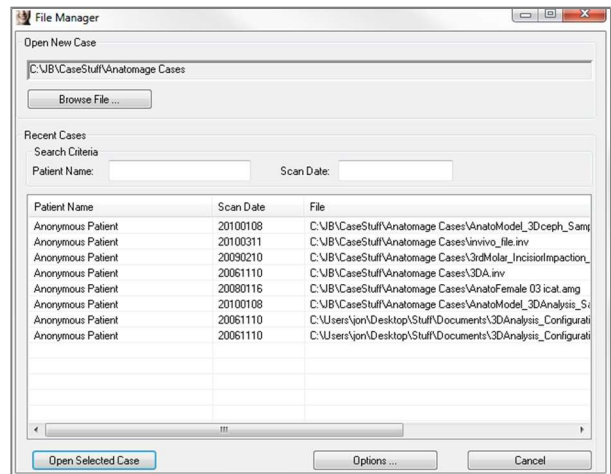
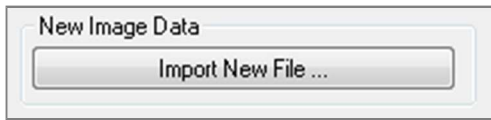

Step 4. Registering the Two Scans to Each Other.

In order to stitch the scans correctly, strict attention must be exercised in selecting at least four matching and stable landmarks in both scans. Use the Registration function: 

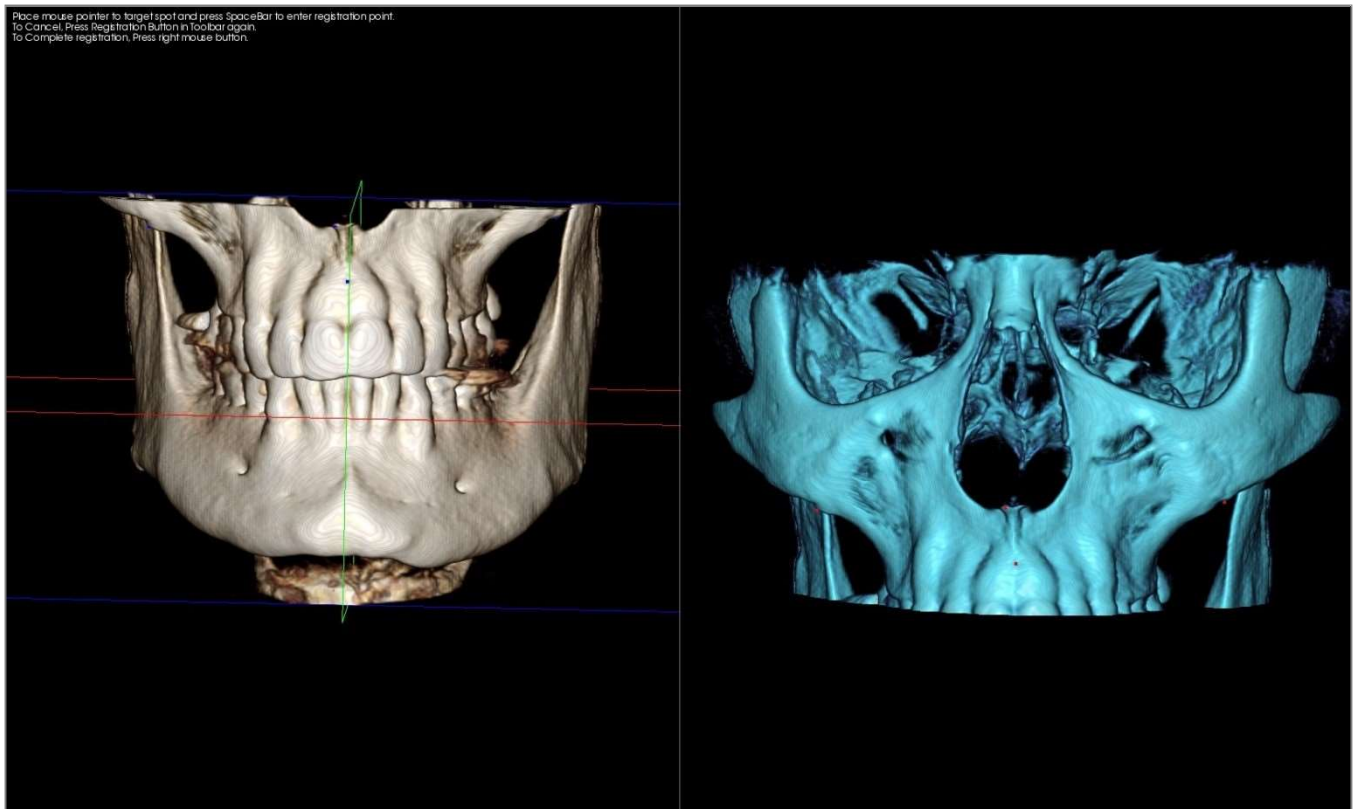

Select the first landmark on one scan, and then select the exact matching landmark on the other scan. The landmarks are selected by pressing the center scroll wheel of the mouse or by the space bar on the keyboard. Each point shows up as blue or red pixels (above). The image can be rotated with the mouse as usual.

Because the points are plotted on the volume, careful attention must be taken so that the brightness is not too high; otherwise, the point could be offset from the point intended. Clipping the scan may make the selection of the exact point easier and potentially more precise.

Once at least four points are plotted and matched, click the right mouse button to register the two scans.

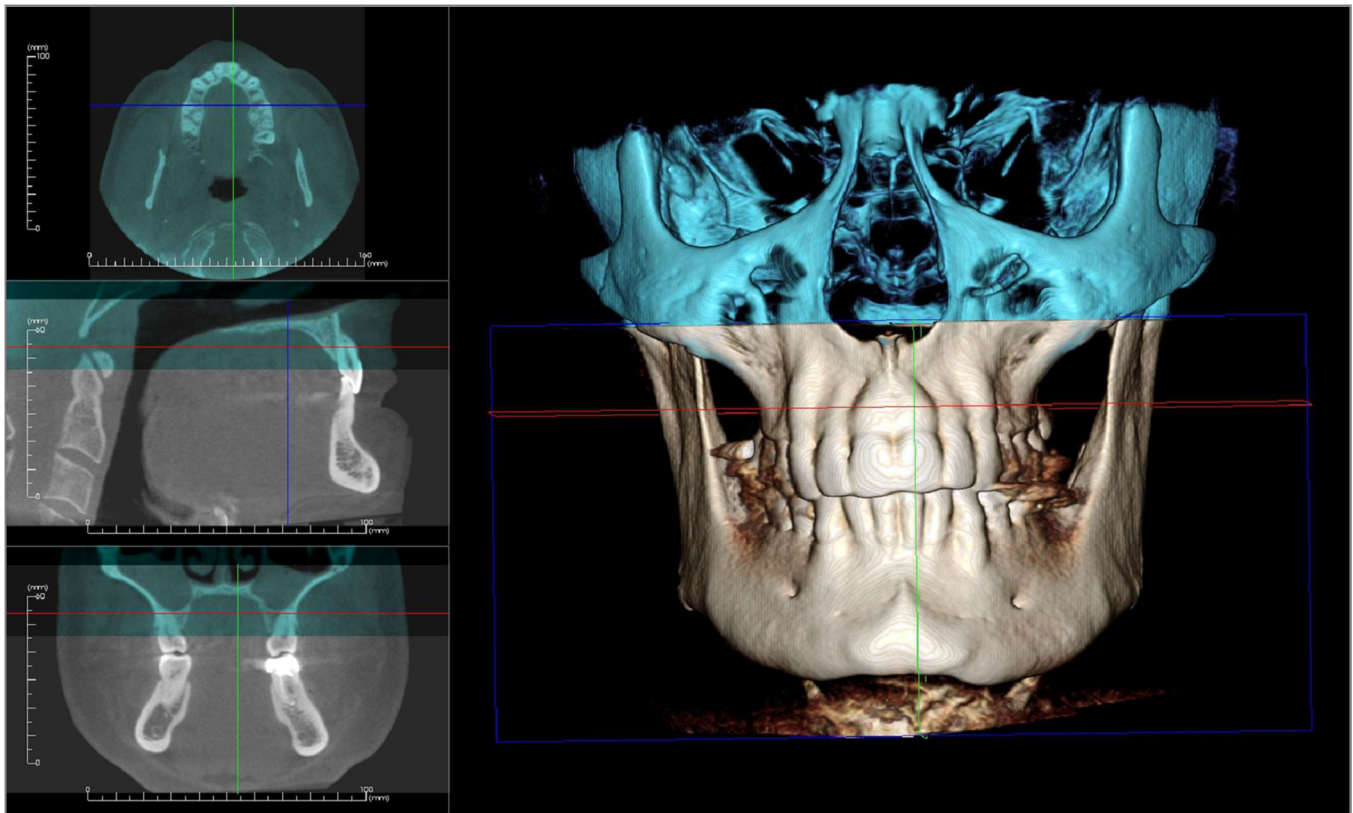

The above image is of an upper and a lower field of view. The blue outline from the second scan closely overlaps the original bone-colored scan in the shared region.

The following image is of two volumes imprecisely registered. The blue and orange skeletal boundaries do not line up, leading to the presence of double images:

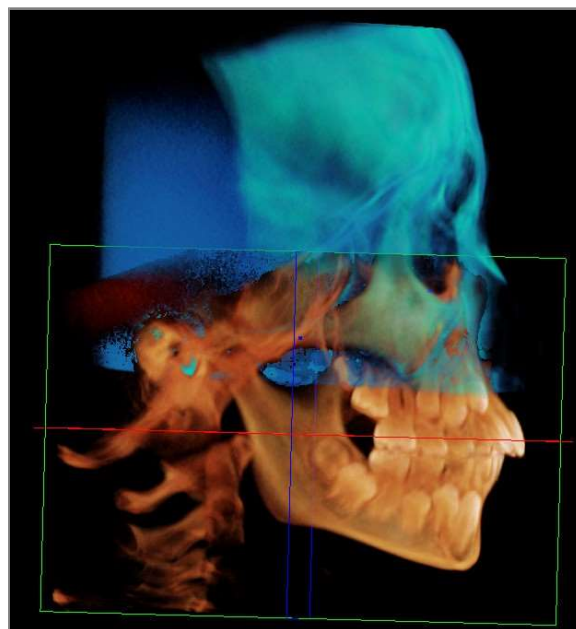

## Step 5. Making Adjustments for Precision.

The next step is to check the cross sections for accuracy and make the necessary adjustments. The stitching is shown in 3D as well as in the cross sections.

To enlarge the cross sections, use the Toggle Layout icon on the toolbar: 

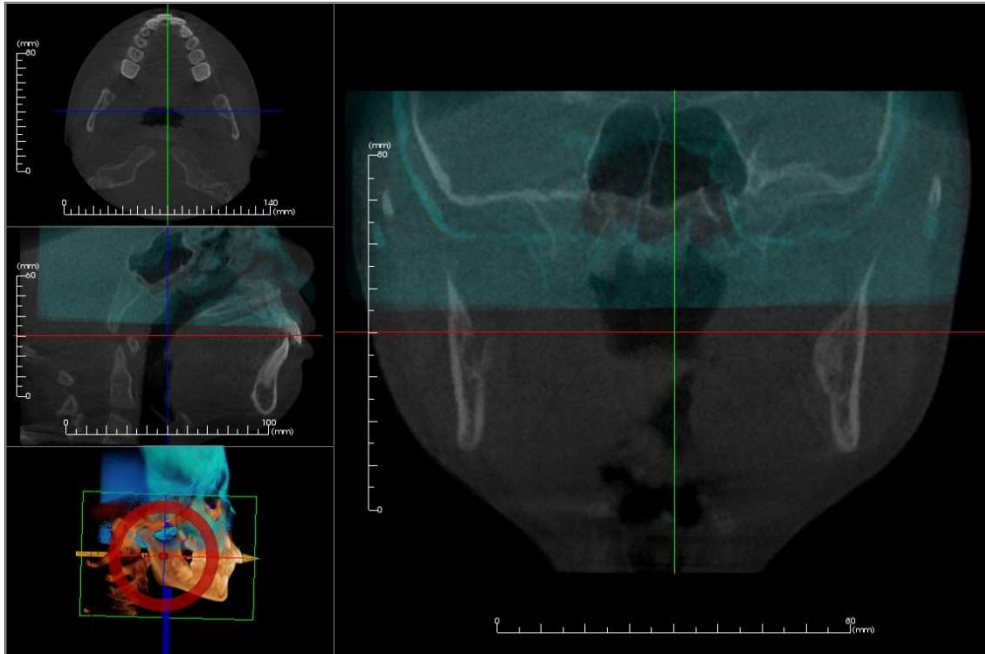

If the stitch is not completely precise in one of the sections, you can move the volume or the cross section for better alignment using the Adjust tool: 

Each anatomical plane should be checked for precision. The cranial base should match up perfectly because it is stable; however the vertebrae may not because the patient's head is usually tilted differently in each scan.

### Step 6. Saving Final Stitched Scan

Use the “Adjust Final Stitched Image Size” tool to set the boundaries by dragging the white handles of the bounding box. Make sure the entire volume range is included.

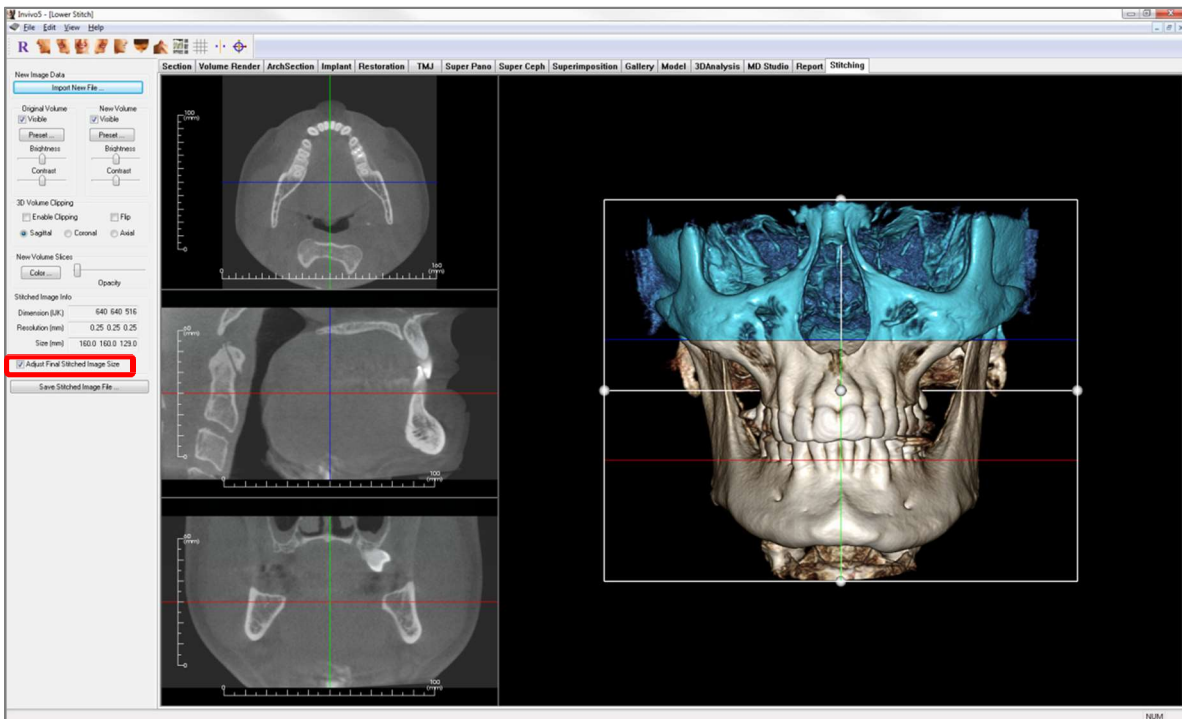

When the bounding box has been adjusted to the size desired, turn off the “Adjust Final Stitched Image Size” function and click the Save Stitched Image File button on the bottom left.

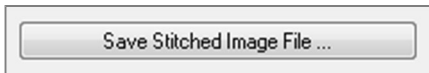

This will save an Invivo file (.inv) with the two scans together as one.



# Invivo5 Software Troubleshooting

Category	Error	Solution
General	Error Message: <i>InVivoDental Application has encountered a problem and needs to close. We are sorry for the inconvenience.</i>	Click the “Don't Send” button. Check if there are old versions of optional plug-ins: remove them or upgrade them to be compatible with InVivoDental. Launch the InVivoDental application again. Warning: Treatment information can only be manually saved. All information added after last saving will be lost.
	Cannot launch InVivoDental	Open Task Manager and check if multiple instances of InVivoDental are already running. Close other InVivoDental processes. Launch the InVivoDental application again.
	Computer failure	Launch the InVivoDental application again. Warning: Treatment information can only be manually saved. All information added after last saving will be lost.
	Error Message: There is no email program associated to perform the requested action. Please install an email program or, if one is already installed, create an association in the Default Programs control panel.	Install an email program. If one is already installed, create an association in the Default Programs option in the Control Panel of the computer.
Installation	Error Message: <i>Server is not Responding</i>	Check Internet connection. If Internet is connected, try again later.
	Error Message: <i>Please run as administrator to activate software</i>	Run the installer/application as administrator.
	Error Message: <i>Failed to verify the license code!</i>	Check the license code and try again. Check Internet connection and try again.
	Error Message: <i>Wrong License Code!</i>	Check the license code and try again.
	Error Message: <i>Invalid Authorization code</i>	Check the license code and try again.
	Error Message: <i>Actual size of the image can't fit to the paper size!</i>	Change printer setting or create an image with smaller size.
File Operations	Error Message: <i>Failed to create process. Please close other applications and try again.</i>	Close all the other applications. Launch the InVivoDental application again.
	Error Message: <i>Error: Cannot read this file</i>	Check if this file is supported by InVivoDental.
	Message: <i>Not enough memory</i>	Close all the other applications. Launch the InVivoDental application again.
	Error Message: <i>Can't create temporary save file!</i>	Check if the remaining disk capacity for the temporary folder is big enough.
	Error Message: <i>Failed to read DICOM file!</i>	Check if this file is supported by InVivoDental.
	Error Message: <i>Can't read Dicom's Image Data!</i>	Check if this file is supported by InVivoDental.
	Try to open a file but nothing showing up	Check if this file is supported by InVivoDental.



	Error Message: <i>Cannot save file!</i>	Check if the file is the correct type. Check if the file path is correct and folder is writable.
Image Rendering	Error Message: <i>Can't detect hardware acceleration for OpenGL support!</i>	Check if the graphics card meets system requirements. Check if the latest driver is installed for the graphics card.
	Image is distorted	Switch to another view and switch back.
	Grayscale image shows up for all rendering presets	Check if the graphics card meets system requirements. Check if the latest driver is installed for the graphics card.
	Warning Message: <i>3D reconstruction may not work!</i>	Check if the DICOM files are exported correctly.

For all other issues, please contact Anatomage Inc. Customer Support at (408) 885-1474.

# Index

*This comprehensive list provides a quick and easy way to find the relevant information that you would like to examine.*

3D Landmark Point.....	43, 122, 136
3DAnalysis View Tab .....	135
Abutment.....	84
Airway Measurement .....	36, 40, 44, 49, 131
Analysis.....	151, 171
Clipping.....	33
AnatoModel .....	132
Apical Space.....	75
Arch Section View Tab.....	51
Arch Spline.....	52, 57, 67, 91, 97, 98, 99
Articulation .....	88
Bone Density.....	75
Bone Graft.....	60, 68
Bridges .....	87
Brightness & Contrast .....	37, 45, 54, 61, 79, 93, 98, 102, 138
Build Crown.....	86
Case Information.....	29
Check Sleeves.....	60, 70
Clipping.....	45, 62, 107, 124, 138
Collision Indicator .....	77, 79
Color Presets .....	54, 61, 93
Comments.....	44, 45, 52, 91, 116, 119
Control Panel .....	18, 37, 45, 54, 61, 79, 93, 98, 102, 107, 116, 124, 138, 189, 208
Coordinate System.....	139, 140, 144, 177
Custom Projection.....	37
Custom Section .....	37
Data Group.....	172
Default Tracing Tasks and Landmarks .....	178
Density Profile .....	60, 63, 75
DICOM.....	23, 25, 120
DICOM & Invivo File Loading .....	23
Export Image.....	120
Export Measurements .....	181, 182
Export Tracing.....	185
Frontal Analysis.....	152, 157
Gallery View Tab.....	115
Grid .....	44, 60, 78, 97, 101, 105, 122, 207
Image Capture.....	29, 30
Image Info .....	37
Implant .....	59, 62
Implant Angles.....	59
Implant Summary.....	59
Implant Types .....	62, 74
Implant View Tab.....	58

Import Image .....	116
Invivo File Saving .....	25
Keyboard Shortcuts .....	191
Landmark .....	150, 167
Layout .....	36, 41, 52, 59, 63, 91, 93, 95, 124, 138, 164, 207, 212
License types .....	13
Life Size .....	54, 93, 102, 130, 138
Measurements .....	36, 43, 45, 52, 59, 77, 91, 97, 101, 105, 122, 136, 150, 155, 169
Menu Bar .....	18
Misch's bone density units .....	75
Model View Tab .....	121
Mouse Navigation Tools .....	31, 39, 57, 63, 65, 94, 190
Move Widget .....	33, 60, 106, 111, 125, 128, 132, 207
Nerve .....	55, 56, 64, 124, 129
Norm Data .....	173, 181
odata .....	107, 114
PACS .....	27
Panoramics .....	57, 67, 96, 99
Patient Info .....	36, 44, 52, 60, 78, 91, 97, 101, 123, 136
Patient Orientation .....	46, 54, 93, 102, 139
Photowrapping .....	125, 137, 158
Pixel Values .....	38
Pontics .....	86
Profilogram .....	137, 186
Quick Measurement .....	44
Reference Lines and Planes .....	150, 170
Registration .....	80, 105, 109, 112, 207, 209
Rendering Methods .....	45
Rendering Window .....	18
Report PDF .....	188
Report View Tab .....	187
Reset Zoom .....	36, 43, 52, 59, 77, 91, 97, 101, 105, 122, 136, 207
Restoration .....	69
Restoration View Tab .....	76
Sassouni Analysis .....	157
Save Tracing .....	182
Sculpt (Free Form) .....	43
Sculpt (Point-to-Point) .....	43
Section View Tab .....	35
Simulation .....	124, 132, 138
Software Layout .....	18
Stitching View Tab .....	206
Stone Model .....	65, 79, 80, 124
Super Ceph View Tab .....	100
Super Pano View Tab .....	96
Superimposition .....	104, 160, 163, 185, 186
Superimposition Adjustment .....	111, 112
Superimposition View Tab .....	104
Surgical Simulation .....	137, 183
Template .....	188, 189, 203

Text View..... 150

TMJ View Tab..... 90

Toolbar ..... 18, 36, 43, 52, 59, 77, 91, 97, 101, 105, 116, 122, 136, 188, 207

Tracing Tasks ..... 137, 144, 166, 176

Tru-Pan..... 54, 61, 98

VCA..... 153, 156

vdata ..... 107, 114

View Sequence ..... 36, 44, 50, 52, 60, 71, 91, 123, 133, 136

View Settings..... 20

View Setup..... 44

View Tabs ..... 18

Visual Preference..... 137, 156, 174, 175

Volume Registration ..... 105, 112

Volume Render View Tab..... 42

Volumetric Measurement..... 44, 48

Waxups ..... 64, 65

Wigglegram ..... 151, 152, 171, 173

## InVivoDental 5.4

InVivoDental is a volumetric imaging software designed specifically for clinicians, doctors, physicians, and other qualified medical professionals



SW-INV-54



17-Aug-21



(01)00852060007082(10)5.4.0



Intended for use by medical and dental professionals.  
Please ensure all hardware devices with the software are password-protected from unauthorized use and all patient information is secure. Please refer to the instructions for use for a complete list of warnings/precautions.



CE 2797



0086



<https://learn.osteoidinc.com/invivo-user-manuals>



Anatmage Inc.  
3350 Scott Boulevard  
Building 29  
Santa Clara, CA 95054 USA  
Tel: +1 (408) 333-3484  
[www.osteoidinc.com](http://www.osteoidinc.com)

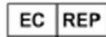

Freyr Life Sciences GmbH  
Marie-Curie-Straße 8,  
D-79539 Lörrach, Germany  
Tuusula, Finland  
Tel: +49 618 170 79007  
<http://www.freyrsolutions.com/>



Qserve Group UK, LTD.  
282 Farnborough Road  
Farnborough, GU14 7NA  
Hampshire, United Kingdom  
Tel: +44 7408 830172  
[www.qservigroup.com](http://www.qservigroup.com)